

Coaxial

Power Splitter/Combiner

ZFSC-2-6+

2 Way-0° 50Ω 0.002 to 60 MHz



Generic photo used for illustration purposes only
CASE STYLE: K18

Connectors	Model
BNC	ZFSC-2-6+
SMA	ZFSC-2-6-S+
N-TYPE	ZFSC-2-6-N+
BRACKET (OPTION)	

+RoHS Compliant
The +Suffix identifies RoHS Compliance. See our web site for RoHS Compliance methodologies and qualifications

Maximum Ratings

Operating Temperature	-55°C to 100°C
Storage Temperature	-55°C to 100°C
Power Input (as a splitter)	1W max.*
Internal Dissipation	0.125W max.

* At low range frequency band (f_L to $10 f_L$), linearly derate maximum input power by 13 dB typ.
Permanent damage may occur if any of these limits are exceeded.

Coaxial Connections

SUM PORT	3
PORT 1	1
PORT 2	2

Outline Drawing

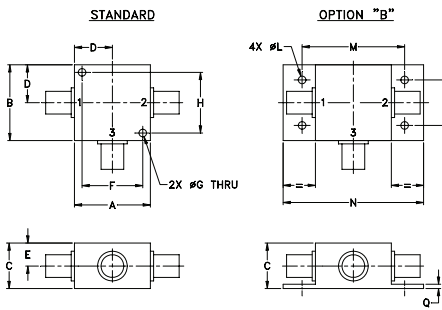

Outline Dimensions (inch/mm)

A	B	C	D	E	F	G	H	J	K	L	M	N	P	Q	wt
1.25	1.25	.75	.63	.38	1.00	.125	1.000	--	--	.125	1.688	2.18	.75	.07	grams
31.75	31.75	19.05	16.00	9.65	25.40	3.18	25.40	--	--	3.18	42.88	55.37	19.05	1.78	70.0

For option B with N-type connectors, dimension "C" increases to 0.94 inches.

Features

- low insertion loss, 0.3 dB typ.
- excellent isolation, 30 dB typ.
- excellent amplitude unbalance, 0.1 dB typ.
- excellent phase unbalance, 0.2 deg. typ.
- rugged shielded case

Applications

- HF
- ham radio
- defense communications

Electrical Specifications

FREQ. RANGE (MHz)	ISOLATION** (dB)			INSERTION LOSS (dB) ABOVE 3.0 dB			PHASE UNBALANCE (Degrees)			AMPLITUDE UNBALANCE (dB)								
	L	M	U	L	M	U	L	M	U	L	M	U						
f_L - f_U	Typ. Min.	Typ. Min.	Typ. Min.	Typ. Max.	Typ. Max.	Typ. Max.	Max.	Max.	Max.	Max.	Max.	Max.						
0.002-60	27	20	30	20	27	20	0.3	0.6	0.3	0.6	0.6	1.0	2	3	4	0.15	0.20	0.30

L = low range [f_L to $10 f_L$] M = mid range [$10 f_L$ to $f_U/2$] U = upper range [$f_U/2$ to f_U]
** Isolation specified to 0.006 MHz

Typical Performance Data

Frequency (MHz)	Total Loss ¹ (dB)		Amplitude Unbalance (dB)	Isolation (dB)	Phase Unbalance (deg.)	VSWR S	VSWR 1	VSWR 2
	S-1	S-2						
0.002	3.16	3.17	0.00	30.24	0.10	1.14	1.20	1.20
0.02	3.10	3.10	0.00	37.52	0.05	1.10	1.04	1.04
0.51	3.11	3.11	0.00	37.86	0.06	1.10	1.03	1.03
2.00	3.13	3.13	0.00	37.35	0.06	1.10	1.03	1.03
5.00	3.18	3.18	0.00	35.22	0.06	1.12	1.02	1.02
8.00	3.22	3.22	0.00	33.04	0.05	1.13	1.01	1.01
11.00	3.25	3.25	0.00	31.28	0.05	1.14	1.01	1.01
15.00	3.29	3.29	0.00	29.45	0.05	1.15	1.01	1.01
19.00	3.33	3.33	0.00	28.06	0.04	1.16	1.02	1.02
26.00	3.38	3.38	0.00	26.35	0.04	1.16	1.05	1.05
36.00	3.46	3.46	0.01	24.95	0.06	1.16	1.09	1.09
42.00	3.52	3.50	0.01	24.54	0.08	1.15	1.11	1.12
48.00	3.57	3.55	0.02	24.37	0.12	1.13	1.15	1.15
54.00	3.63	3.61	0.02	24.36	0.16	1.12	1.18	1.19
60.00	3.70	3.66	0.03	24.35	0.22	1.12	1.22	1.23

1. Total Loss = Insertion Loss + 3dB splitter loss.

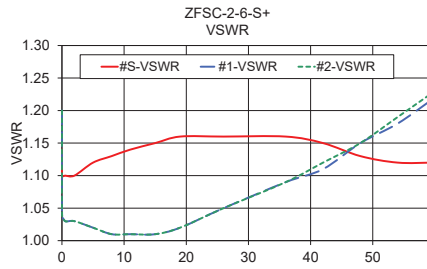
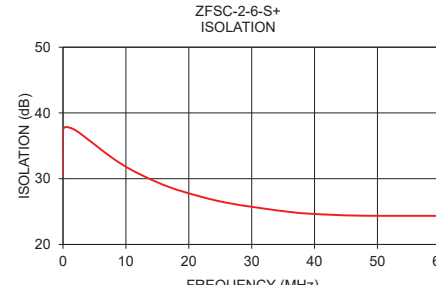
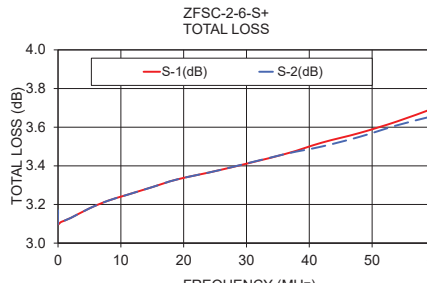

electrical schematic



Notes

- Performance and quality attributes and conditions not expressly stated in this specification document are intended to be excluded and do not form a part of this specification document.
- Electrical specifications and performance data contained in this specification document are based on Mini-Circuit's applicable established test performance criteria and measurement instructions.
- The parts covered by this specification document are subject to Mini-Circuits standard limited warranty and terms and conditions (collectively, "Standard Terms"); Purchasers of this part are entitled to the rights and benefits contained therein. For a full statement of the Standard Terms and the exclusive rights and remedies thereunder, please visit Mini-Circuits' website at www.minicircuits.com/MCLStore/terms.jsp

