



LTCC SURFACE MOUNT

# Low Pass Filter

## LFCV-1800-75+

Mini-Circuits

75Ω 10 to 1800 MHz

### THE BIG DEAL

- Stop Band Rejection, 25 dB Min.
- Low Insertion Loss, 1.5 dB Max.
- Pass Band Return Loss, 15 dB Typ.
- Rugged Ceramic Construction
- Small Size, 1210 Surface Mount Footprint

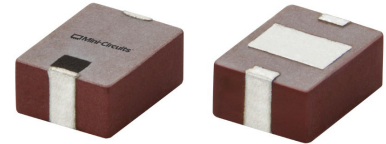

Generic photo used for illustration purposes only

### FUNCTIONAL DIAGRAM

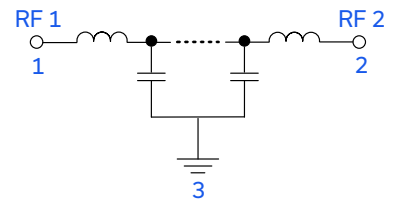

### APPLICATIONS

- Cable / CATV Systems
- Broadband Fiber Networks
- Harmonic Rejection
- Test & Measurement Equipment

### PRODUCT OVERVIEW

Mini-Circuits' LFCV-1800-75+ is a miniature low-temperature co-fired ceramic (LTCC) 75Ω low pass filter with a 10 to 1800 MHz passband that supports a variety of applications. This model provides 1.5 dB maximum insertion loss over a wide band, due to its rugged monolithic construction. Housed in a small 1210 ceramic form factor with excellent passband return loss of 15 dB typical, this filter is ideal for CATV and Broadband Fiber Network applications. The LTCC fabrication process assures minimal RF performance variation, while delivering a product that is well-suited for environmental extremes of high humidity and temperature.

### KEY FEATURES

Feature	Advantages
High Rejection	With 25 dB minimum stopband rejection, this filter is ideally suited for CATV applications to enhance the system dynamic range.
LTCC Construction	The use of LTCC technology allows for repeatable performance in a rugged ceramic package, well suited for tough environments such as high humidity and temperature extremes.
Excellent Performance for Size	Offers best in class performance relative to larger-size alternative technologies. This multi-layer surface mount LTCC filter in a 1210 package allows for space to be saved in dense circuit board layouts, while also minimizing the effects of parasitics.

REV. A  
 ECO-021994  
 LFCV-1800-75+  
 MCL NY  
 250610





LTCC SURFACE MOUNT

# Low Pass Filter

## LFCV-1800-75+

Mini-Circuits

75Ω 10 to 1800 MHz

### ELECTRICAL SPECIFICATIONS<sup>1,2,3</sup> AT 25°C

Parameter	F#	Frequency (MHz)	Min.	Typ.	Max.	Units
Passband	Insertion Loss	F1-F2	10 - 1800	—	—	1.5
	Freq. Cut-Off <sup>4</sup>	Fc	2200	—	3	dB
	Return Loss	F1-F2	10 - 1800	—	15	—
Stopband	Rejection	F3-F4	2750 - 4000	32	—	—
		F4-F5	4000 - 5000	25	—	—

1. Tested on Evaluation Board P/N TB-LFCV180075C+ with Port Extension performed.

2. Bi-directional RF1 and RF2 ports can be interchanged.

3. In applications where DC voltage and/or current is present at either the input or output ports, external DC blocking capacitors are required.

4. Typical variation ±5%.

### ABSOLUTE MAXIMUM RATINGS<sup>5</sup>

Parameter	Ratings
Operating Temperature	-55°C to +105°C
Storage Temperature	-55°C to +105°C
RF Power Input <sup>6</sup>	2 W

5. Permanent damage may occur if any of these limits are exceeded.

6. Power rating applies only to signals within the passband. Power rating above +25°C operating temperature decreases linearly to 1 W at +105°C.

### TYPICAL FREQUENCY RESPONSE AT 25°C

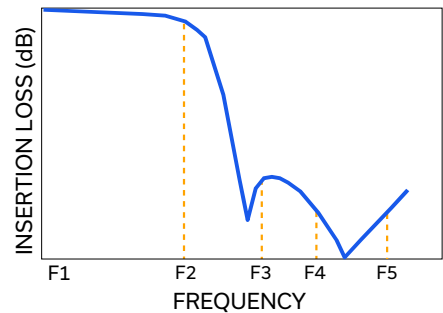



### TYPICAL PERFORMANCE GRAPHS

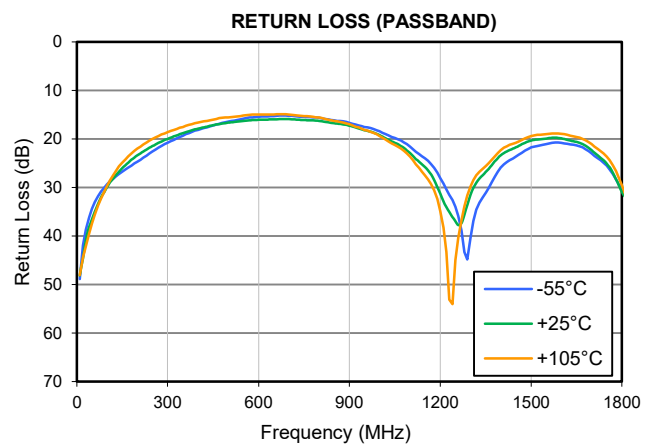
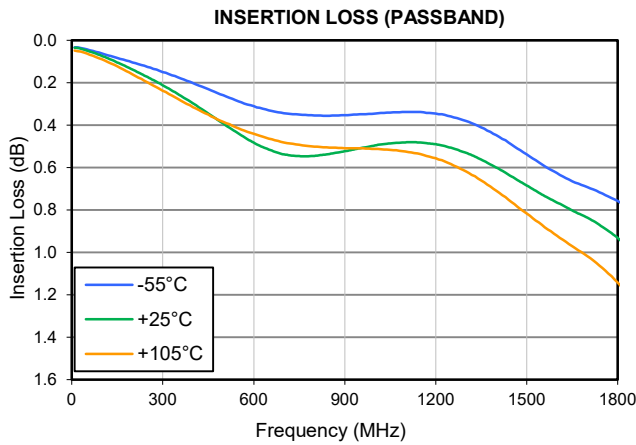
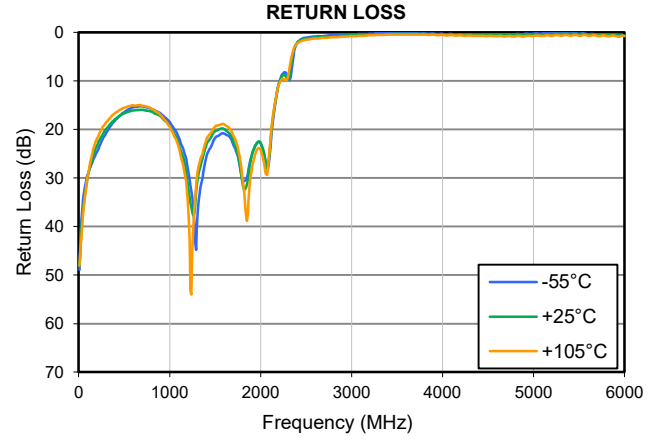
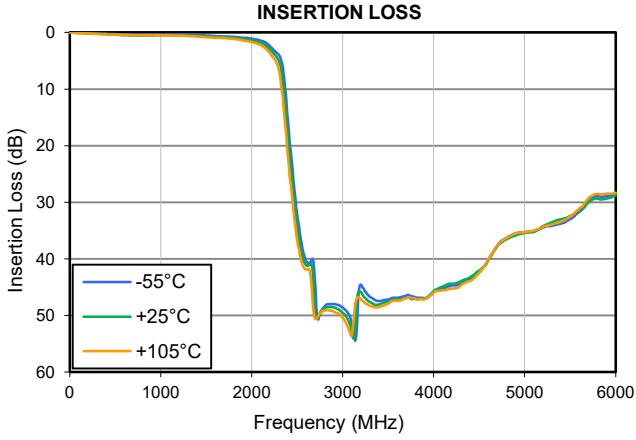



### FUNCTIONAL DIAGRAM

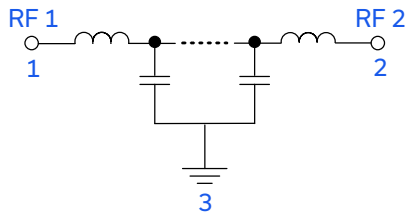
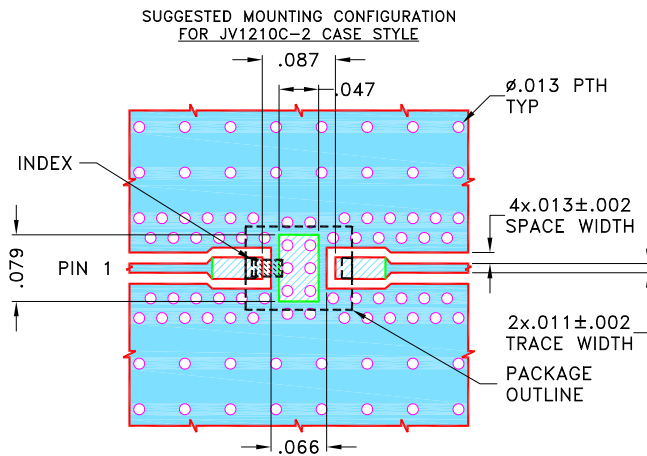

Figure 1. LFCV-1800-75+ Functional Diagram

### PAD DESCRIPTION

Function	Pad Number	Description
RF1 <sup>2</sup>	1	Connects to RF Input Port
RF2 <sup>2</sup>	2	Connects to RF Output Port
GROUND	3	Connects to Ground on PCB, (See drawing PL-680)

### SUGGESTED PCB LAYOUT (PL-680)



NOTES:

1. COPLANAR WAVEGUIDE PARAMETERS ARE SHOWN FOR ROGERS (R04350B) WITH DIELECTRIC THICKNESS  $.010 \pm .001$ ; COPPER: 1/2 Oz. EACH SIDE. FOR OTHER MATERIALS TRACE WIDTH AND GAP MAY NEED TO BE MODIFIED.
  2. BOTTOM SIDE OF THE PCB IS CONTINUOUS GROUND PLANE.
- DENOTES PCB COPPER PATTERN WITH SMOBC (SOLDER MASK OVER BARE COPPER)  
 DENOTES PCB COPPER PATTERN FREE OF SOLDERMASK

Figure 2. Suggested PCB Layout PL-680

### CASE STYLE DRAWING

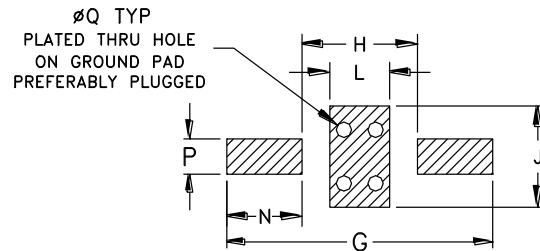
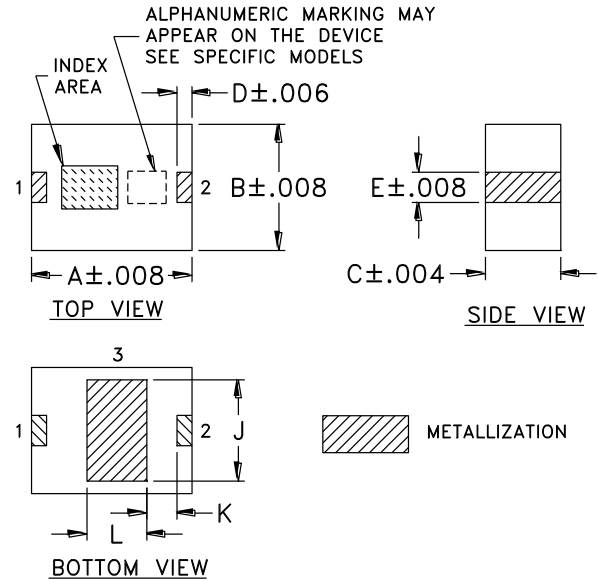

Suggested Layout,  
Tolerance to be within  $\pm .002$

### OUTLINE DIMENSIONS (Inch/mm)

A	B	C	D	E	G	H
.126	.098	.059	.012	.024	.205	.087
3.2	2.5	1.5	0.3	0.61	5.2	2.2
J	K	L	N	P	Q	wt
.079	.028	.047	.059	0.026	0.012	grams
2.0	0.7	1.2	1.5	0.7	0.3	0.045

### PRODUCT MARKING\*: N/A

\*Marking may contain other features or characters for internal lot control.



LTCC SURFACE MOUNT

# Low Pass Filter

## LFCV-1800-75+

Mini-Circuits

75Ω 10 to 1800 MHz

ADDITIONAL INFORMATION IS AVAILABLE ON OUR DASHBOARD

[CLICK HERE](#)

Performance Data & Graphs	Data Graphs S-Parameter (S2P Files) Data Set (.zip file) De-embedded to device pads
Case Style	JV1210C-2      Lead Finish: Tin over Nickel Plating
RoHS Status	Compliant
Tape and Reel	F74
Suggested Layout for PCB Design	PL-680
Evaluation Board	TB-LFCV180075C+ Gerber File
Environmental Ratings	ENV06T13

### NOTES

- A. Performance and quality attributes and conditions not expressly stated in this specification document are intended to be excluded and do not form a part of this specification document.
- B. Electrical specifications and performance data contained in this specification document are based on Mini-Circuit's applicable established test performance criteria and measurement instructions.
- C. The parts covered by this specification document are subject to Mini-Circuits standard limited warranty and terms and conditions (collectively, "Standard Terms"); Purchasers of this part are entitled to the rights and benefits contained therein. For a full statement of the standard. Terms and the exclusive rights and remedies thereunder, please visit Mini-Circuits' website at [www.minicircuits.com/terms/viewterm.html](http://www.minicircuits.com/terms/viewterm.html)

