



MMIC SURFACE MOUNT

Monolithic Amplifier

LEE1-84+

50Ω DC to 4000 MHz

THE BIG DEAL

- High Gain, Typ. 19.1 dB
- High OIP3, Typ. +35 dBm
- High P1dB, Typ. +20.9 dBm
- Single Supply Voltage, 108 mA at +5 V
- 1.5×1.5 mm 6-Lead QFN-Style Package

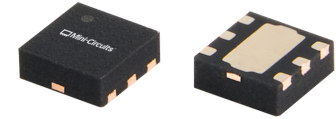

Generic photo used for illustration purposes only

APPLICATIONS

- Satellite Communications
- 5G MIMO and Backhaul MW Radio Systems
- Radar, EW and ECM Defense Systems
- ISM Band Applications

FUNCTIONAL DIAGRAM (TOP VIEW)

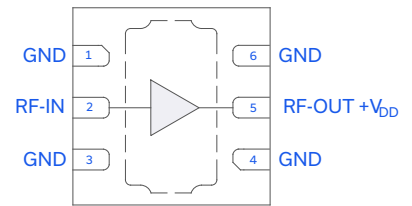

PRODUCT OVERVIEW

The LEE1-84+ is a high-linearity gain block amplifier in a low-cost surface mount package, fabricated using an InGaP/GaAs HBT semiconductor process. Operating from DC to 4000 MHz, this amplifier features high dynamic range with typical 5 dB noise figure, 19.1 dB gain, +20.9 dBm P1dB, and +35 dBm OIP3 at 2 GHz. This combination of performance makes it ideal for sensitive, high dynamic range receiver applications. The LEE1-84+ operates on a single +5 V supply and consumes 108 mA, is well matched to 50Ω, and comes in a small, low-profile 1.5×1.5 mm QFN-style package for ease of integration into dense circuit board layouts.

KEY FEATURES

Features	Advantages
Low Power Consumption, Typ. 108 mA at +5 V	At only 108 mA, this amplifier is ideal for applications with limited available power or densely packed applications where thermal and power management is critical
High Dynamic Range <ul style="list-style-type: none"> • OIP3, Typ. +35 dBm at 2 GHz • P1dB, Typ. +20.9 dBm at 2 GHz 	The LEE1-84+ matches industry leading OIP3 performance relative to device size and power consumption. The combination of high linearity and output power make this gain block amplifier ideal for use as a second stage in ultra-high dynamic range receivers.
1.5×1.5 mm 6-Lead QFN-Style Package	Very small footprint saves space in dense PCB layouts while providing low inductance, repeatable transitions, and excellent thermal contact with the PCB. Industry standard packaging allows for ease of assembly in high volume manufacturing processes.





MMIC SURFACE MOUNT

Monolithic Amplifier

LEE1-84+

Mini-Circuits

50Ω DC to 4000 MHz

ELECTRICAL SPECIFICATIONS¹ AT +25 °C, I_{DD} = 108 mA, V_{DD} = +5 V, UNLESS NOTED OTHERWISE

Parameter	Frequency (MHz)	Min.	Typ.	Max.	
Frequency Range		DC ⁶		4000	MHz
Gain	10	23.8	24.6		dB
	1000	21.4	22.5		
	2000	18.0	19.1		
	3000	15.2	16.3		
	4000	12.8	14.0		
Input Return Loss	10		26		dB
	1000		23		
	2000		20		
	3000		17		
	4000		15		
Output Return Loss	10		22		dB
	1000		11		
	2000		8		
	3000		7		
	4000		7		
Isolation	10-4000		24.2		dB
Output Power at 1 dB Compression (P _{1dB})	10		+20.9		dBm
	1000		+21.0		
	2000		+20.9		
	3000		+19.8		
	4000		+19.2		
Output Third-Order Intercept Point (P _{OUT} = 0 dBm/Tone)	10		+33		dBm
	1000		+34		
	2000		+35		
	3000		+32		
	4000		+31.5		
Noise Figure	10		4.9		dB
	1000		4.9		
	2000		5.0		
	3000		5.1		
	4000		5.3		
Device Operating Voltage (V _{DD}) ²		+4.75	+5	+5.25	V
Device Operating Current (I _{DD}) ³			108		mA
Device Current Variation vs. Temperature ⁴			0.075		mA/°C
Device Current Variation vs. Voltage ⁵			0.052		mA/mV

1. Tested on Mini-Circuits Characterization Test Board MB-225-84C+. See Figure 2. Board loss de-embedded to the device.

2. Operating voltage applied to device LEE1-84+.

3. Current at P_{IN} = -25 dBm.

4. (Current at +105 °C - Current at -55 °C) / (+105 °C - -55 °C)

5. (Current at +5.25 V - Current at +4.75 V) / (+5.25 V - +4.75 V)

6. Low frequency cut off determined by external coupling capacitor.





TYPICAL PERFORMANCE GRAPHS

Note: The following data was taken on the Mini-Circuits Characterization Test Board MB-225-84C+ (Figure 2).

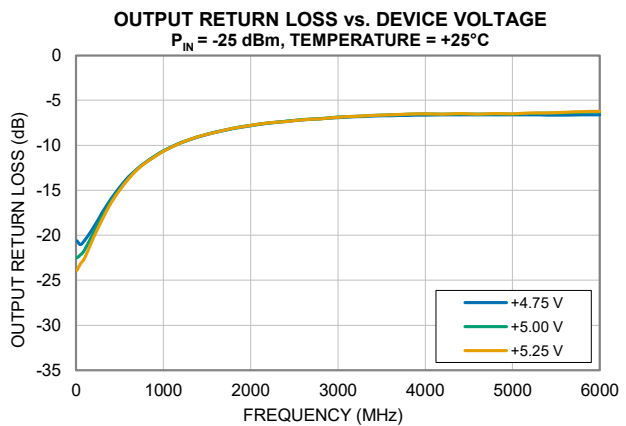
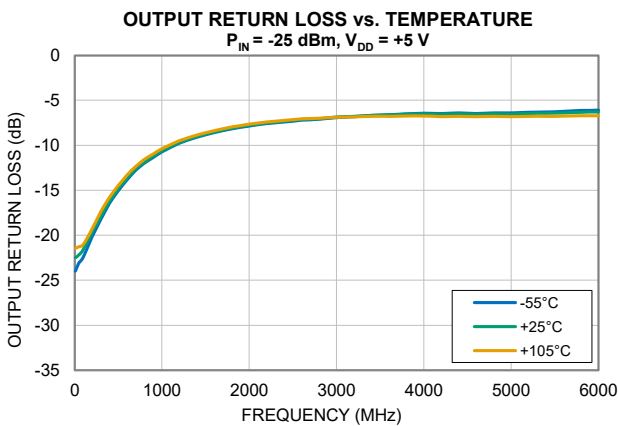
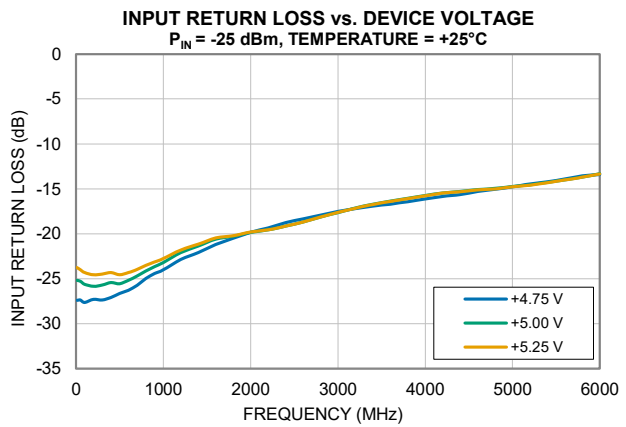
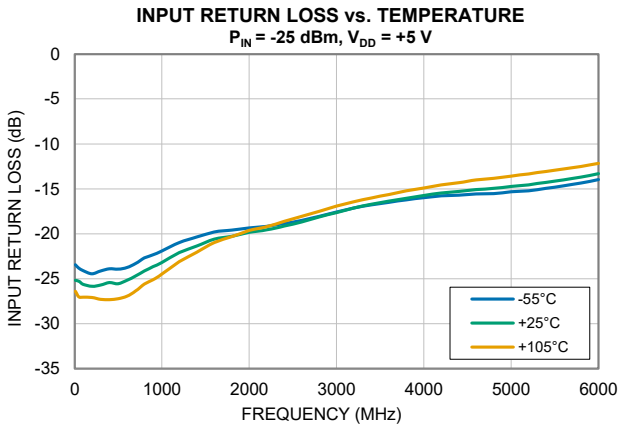
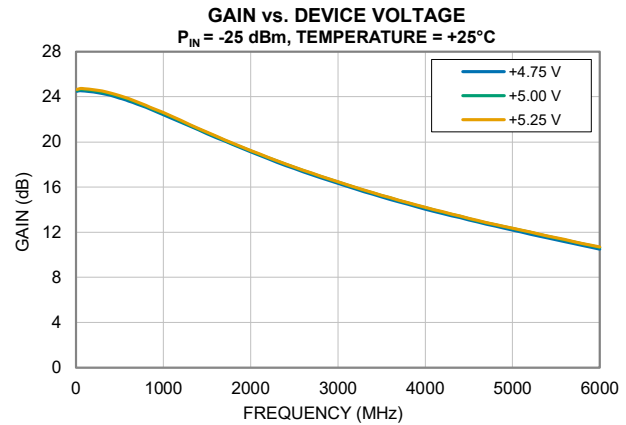
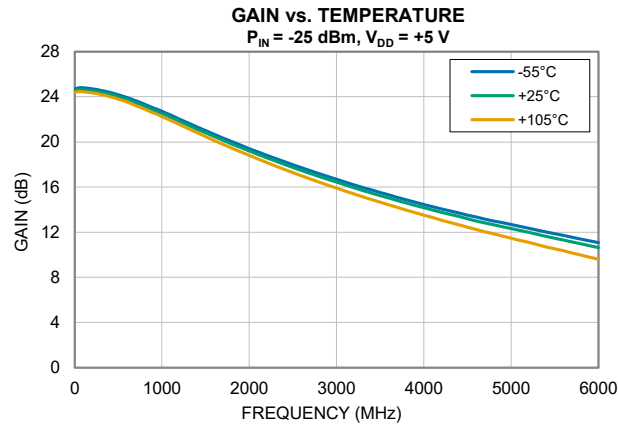



TYPICAL PERFORMANCE GRAPHS

Note: The following data was taken on the Mini-Circuits Characterization Test Board MB-225-84C+ (Figure 2).

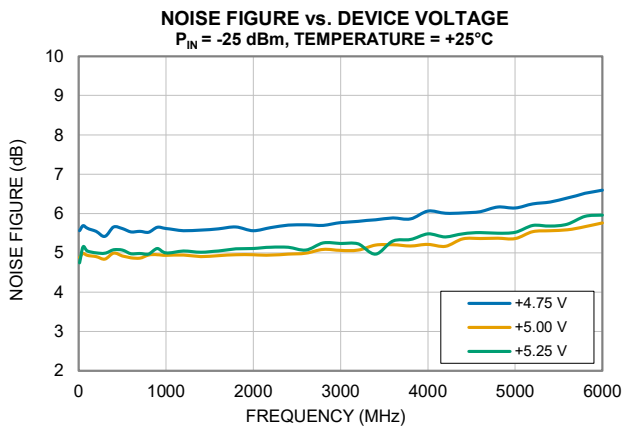
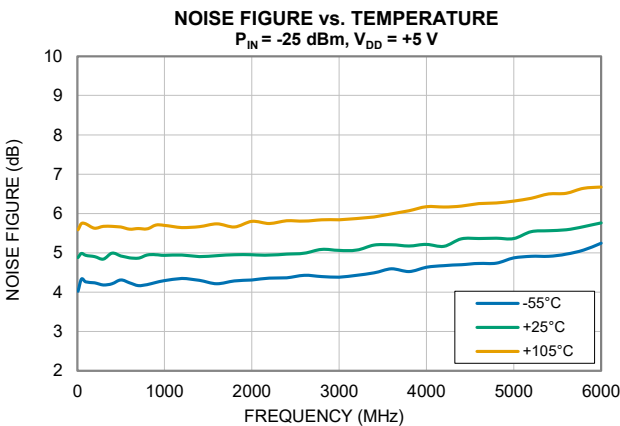
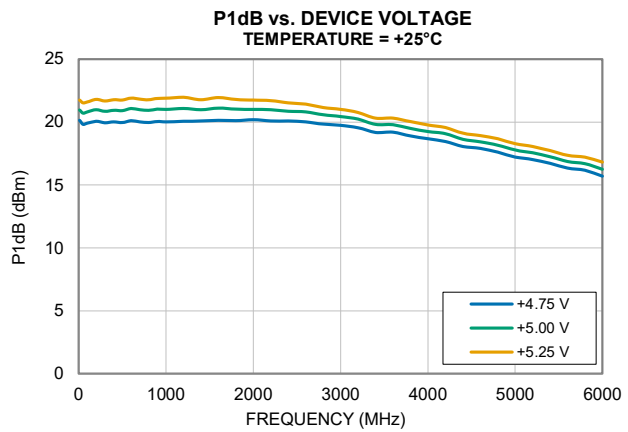
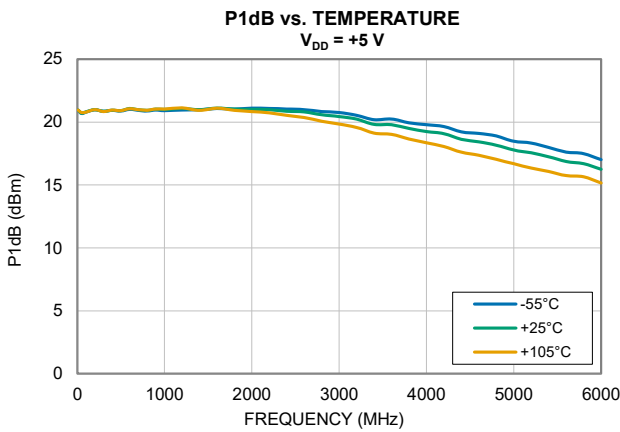
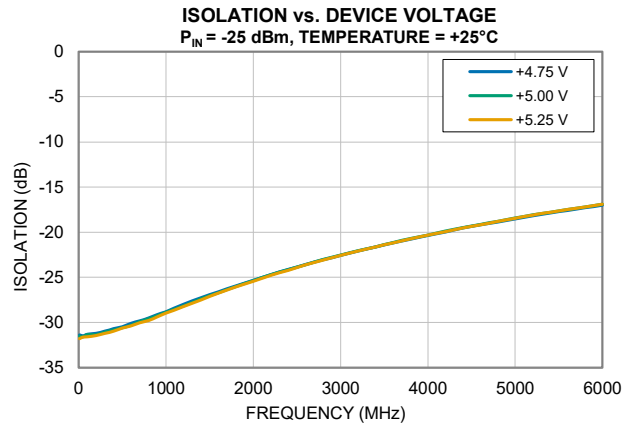
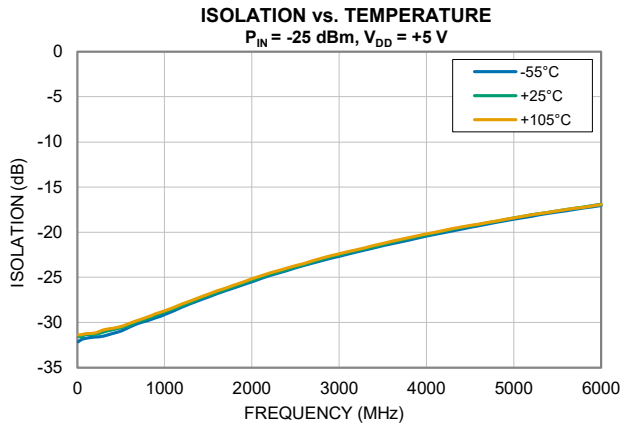



TYPICAL PERFORMANCE GRAPHS

Note: The following data was taken on the Mini-Circuits Characterization Test Board MB-225-84C+ (Figure 2).

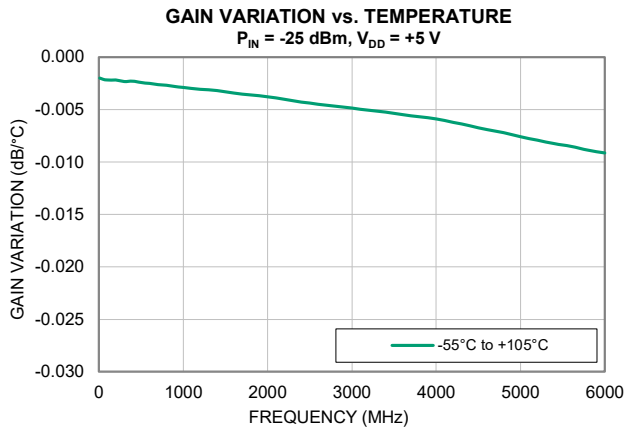
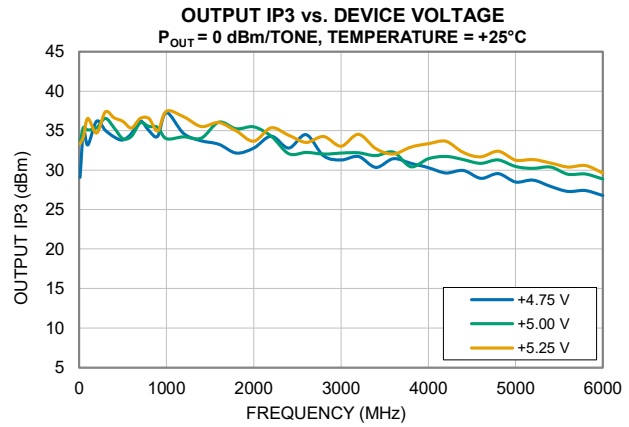
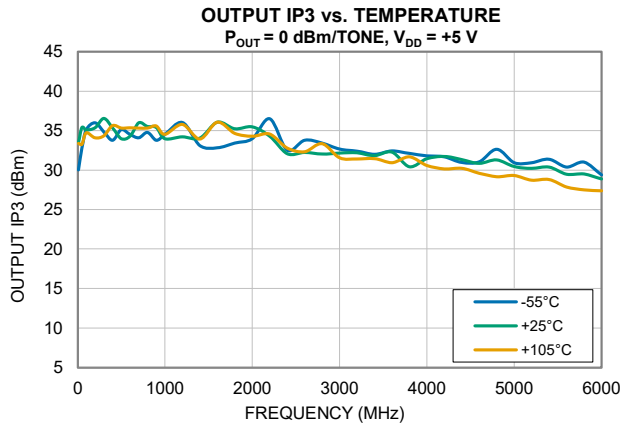



MMIC SURFACE MOUNT

Monolithic Amplifier

LEE1-84+

50Ω DC to 4000 MHz

ABSOLUTE MAXIMUM RATINGS⁷

Parameter	Ratings
Operating Temperature	-55 °C to +105 °C
Storage Temperature	-65 °C to +150 °C
Junction Temperature ⁸	+150 °C
Total Power Dissipation	0.88 W
Input Power (CW), $V_{DD} = 108$ mA	+13 dBm
DC Voltage at V_{DD}	+5.8 V
DC Current I_{DD}	160 mA

7. Permanent damage may occur if any of these limits are exceeded. Maximum ratings are not intended for continuous normal operation.

8. Peak temperature on top of Die.

THERMAL RESISTANCE

Parameter	Ratings
Thermal Resistance (Θ_{JC}) ⁹	50.9 °C/W

9. Θ_{JC} = (Hot Spot Temperature on Die - Temperature at Ground Lead)/Dissipated Power

ESD RATING

	Class	Voltage Range	Reference Standard
HBM	1C	1000 V to < 2000 V	ANSI/ESDA/JEDEC JS-001-2023
CDM	C3	> 1000 V	ANSI/ESDA/JEDEC JS-002-2022



ESD HANDLING PRECAUTION: This device is designed to be Class 1C for HBM. Static charges may easily produce potentials higher than this with improper handling and can discharge into DUT and damage it. As a preventive measure industry standard ESD handling precautions should be used at all times to protect the device from ESD damage.

MSL RATING

Moisture Sensitivity: MSL1 in accordance with IPC/JEDEC J-STD-020E /JEDEC J-STD-033C



MMIC SURFACE MOUNT

Monolithic Amplifier

LEE1-84+

Mini-Circuits

50Ω DC to 4000 MHz

FUNCTIONAL DIAGRAM (TOP VIEW)

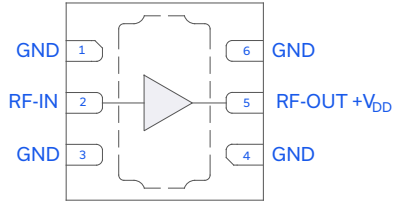

Figure 1. LEE1-84+ Functional Diagram

PAD DESCRIPTION

Function	Pad Number	Description (Refer to Fig 2)
RF-IN	2	RF-IN Pad connects to RF Input port.
RF-OUT + V _{DD}	5	RF-OUT Pad connects to RF Output port. V _{DD} is applied via external bias tee.
GND	1, 3, 4, 6 & Paddle	Connects to ground.

CHARACTERIZATION TEST BOARD

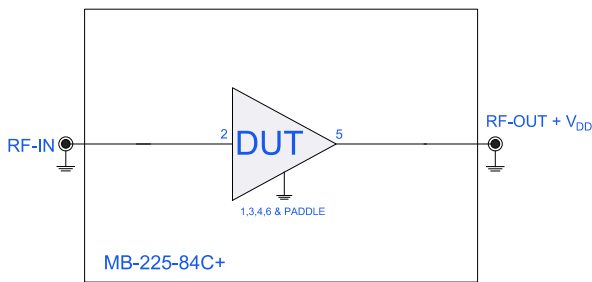

Figure 2. LEE1-84+ Characterization Circuit

Electrical Parameters and Conditions

Gain, Return Loss, Output Power at 1dB Compression (P1dB), Output IP3 (OIP3), and Noise Figure measured using N5242A PNA-X microwave network analyzer.

Conditions:

- Gain and Return Loss: P_{IN} = -25 dBm
- Output IP3 (OIP3): Two tones, spaced 1 MHz apart, 0 dBm/Tone at output.
- I_{DD} = 108 mA at V_{DD} = +5 V Typ

EVALUATION BOARD

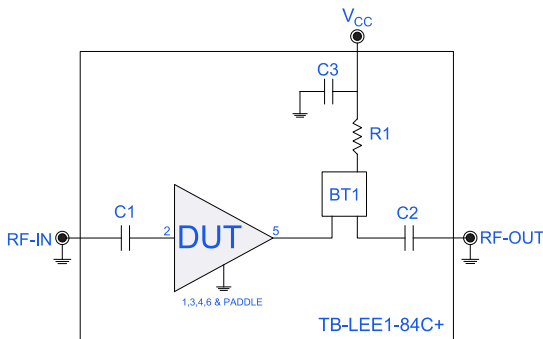

Figure 3. LEE1-84+ Evaluation Circuit

Electrical Parameters and Conditions

Gain, Return Loss, Output Power at 1dB Compression (P1dB), Output IP3 (OIP3), and Noise Figure measured using N5242A PNA-X microwave network analyzer.

Conditions:

- Gain and Return Loss: P_{IN} = -25 dBm
- Output IP3 (OIP3): Two tones, spaced 1 MHz apart, 0 dBm/Tone at output.
- V_{CC} = V_{DD} = +5 V

Component	Value	Size	Part Number	Manufacturer
C1, C2	2.4 nF	0402	GRM1557U1A242JA1D	Murata
C3	0.1 μF	0805	GCM21BR91H104KA37L	Murata
R1	0Ω, 0.5W	1210	RC1210FR-070RL	Yageo
BT1	-	3.8×3.8 mm	TCBT-14+	Mini-Circuits



TYPICAL PERFORMANCE GRAPHS

Note: The following data was taken on the Mini-Circuits Evaluation Board TB-LEE1-84C+ (Figure 3).

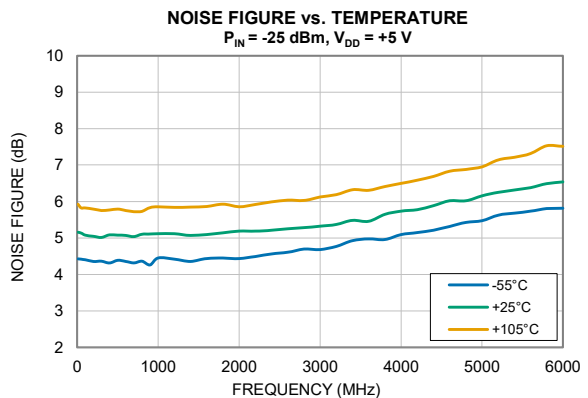
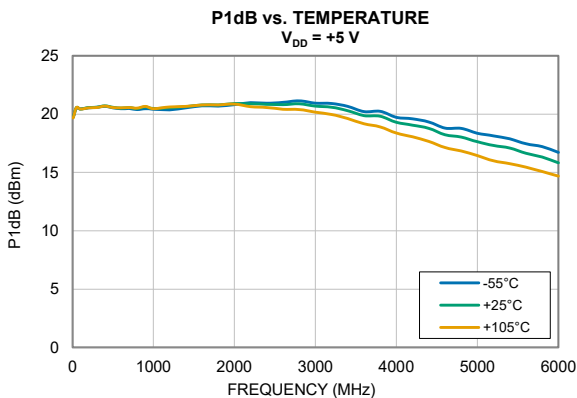
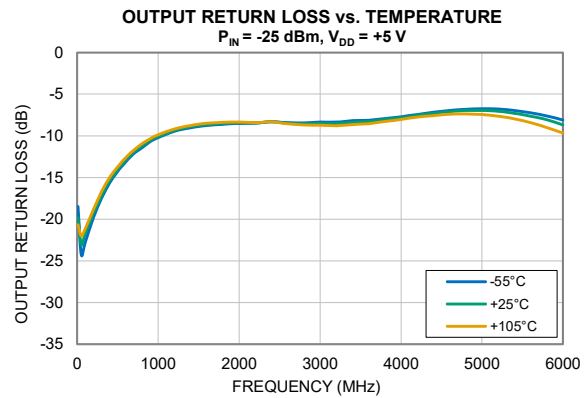
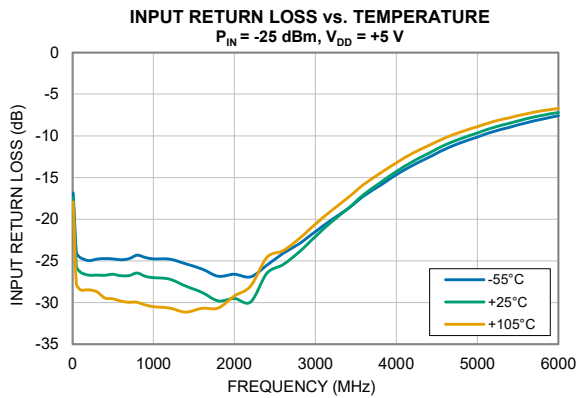
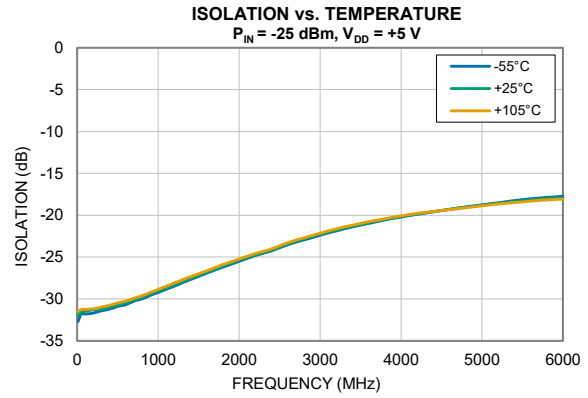
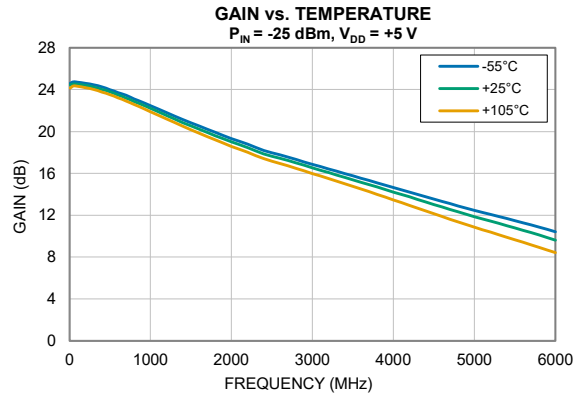



TYPICAL PERFORMANCE GRAPHS

Note: The following data was taken on the Mini-Circuits Evaluation Board TB-LEE1-84C+ (Figure 3).

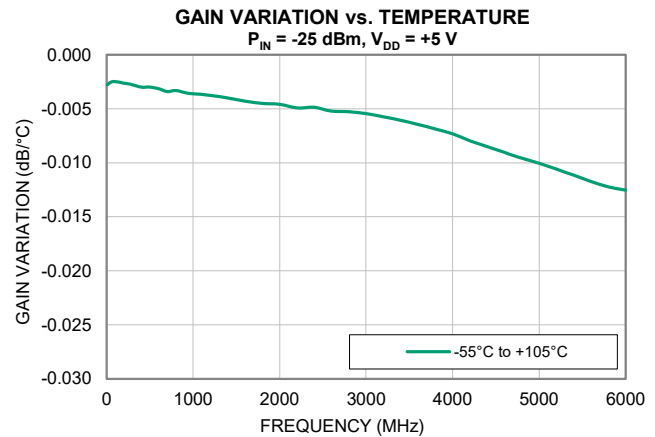
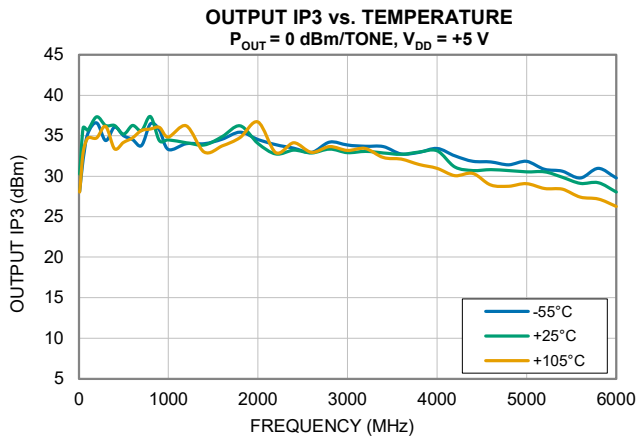



MMIC SURFACE MOUNT

Monolithic Amplifier

LEE1-84+

Mini-Circuits

50Ω DC to 4000 MHz

CASE STYLE DRAWING

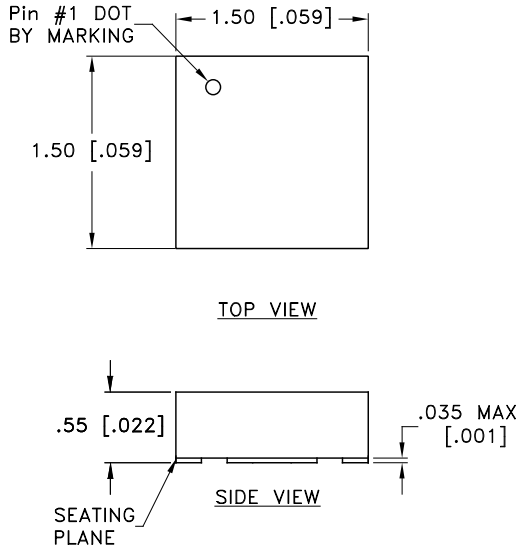

PCB Land Pattern

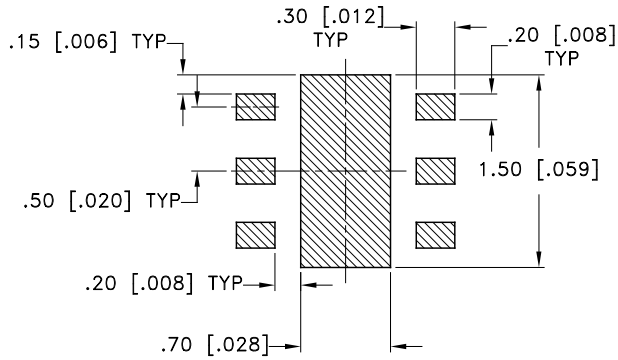

Suggested Layout,
Tolerance to be within ±0.050 mm

NOTES:

1. DENOTES METALLIZATION

Weight: 0.0036 grams

Dimensions are in mm [inches]. Tolerances: 2Pl. ±0.05 mm [0.002 inches].

PRODUCT MARKING

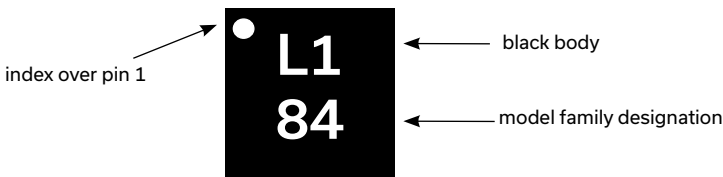

Marking may contain other features or characters for internal lot control



MMIC SURFACE MOUNT

Monolithic Amplifier

LEE1-84+

50Ω DC to 4000 MHz

Mini-Circuits

ADDITIONAL DETAILED INFORMATION IS AVAILABLE ON OUR DASHBOARD

[CLICK HERE](#)

Performance Data & Graphs	Data Graphs S-Parameter (S2P Files) Data Set (.zip file)
Case Style	KC3011 Plastic package, exposed paddle, Lead Finish: Nickel Palladium Gold
RoHS Status	Compliant
Tape & Reel Standard quantities available on reel	F66 7" reels with 20, 50, 100, 200, 500, 1000, 2000, or 3000 devices
Suggested Layout for PCB Design	PL-851
Evaluation Board	TB-LEE1-84C+ Gerber File
Environmental Ratings	ENV08T1

NOTES

- A. Performance and quality attributes and conditions not expressly stated in this specification document are intended to be excluded and do not form a part of this specification document.
- B. Electrical specifications and performance data contained in this specification document are based on Mini-Circuit's applicable established test performance criteria and measurement instructions.
- C. The parts covered by this specification document are subject to Mini-Circuits standard limited warranty and terms and conditions (collectively, "Standard Terms"); Purchasers of this part are entitled to the rights and benefits contained therein. For a full statement of the standard terms and the exclusive rights and remedies thereunder, please visit Mini-Circuits' website at www.minicircuits.com/terms/viewterm.html

