



LTCC SURFACE MOUNT

# High Pass Filter

## HFHKI-5000+

50Ω 5.6 to 16 GHz

### THE BIG DEAL

- Low Insertion Loss, Typ. 1.2 dB
- Passband Return Loss, Typ. 13.5 dB
- Stopband Rejection, Typ. 66 dB
- 1210 Surface Mount Footprint
- Power Handling: 6 W
- Integrated CPWG interposer for easy SMT integration
- Protected by US Patents 11,638,370 and 11,744,057

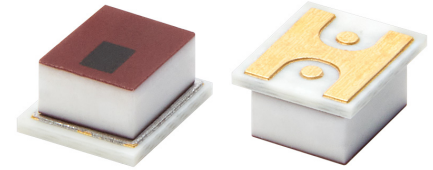

Generic photo used for illustration purposes only

### APPLICATIONS

- C, X and Ku-band Radar Systems
- EW / ECM Wideband Receivers
- Test and Measurement Equipment
- Higher-Band Wireless and Backhaul

### FUNCTIONAL DIAGRAM

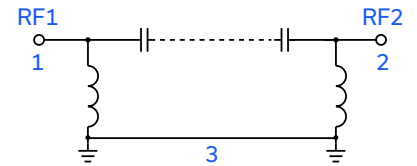

### PRODUCT OVERVIEW

Mini-Circuits' HFHKI-5000+ is a miniature low temperature co-fired ceramic (LTCC) high pass filter with a 5.6 to 16 GHz passband that supports a variety of applications. This model provides 1.2 dB typical insertion loss over a wide band due to its rugged monolithic construction. The small 1210 form factor makes this filter ideal for dense signal chain PCB layouts where it complements MMIC size and performance. The LTCC fabrication process ensures minimal RF performance variation while delivering a product that is well suited for environmental extremes of high humidity and temperature.

### ELECTRICAL SPECIFICATIONS<sup>1,2,3</sup> AT +25 °C, Z<sub>0</sub> = 50 Ω

Parameter		F#	Frequency (GHz)	Min.	Typ.	Max.	Units
Passband	Insertion Loss	F4-F5	5.6-6.9	—	2.5	—	dB
		F5-F6	6.9-14.5	—	1.2	1.9	
		F6-F7	14.5-16	—	2.2	3.0	
Passband	Return Loss	F4-F5	5.6-6.9	—	7.5	—	dB
		F5-F6	6.9-14.5	—	10.5	—	
		F6-F7	14.5-16	—	13.5	—	
Stopband	Rejection	DC-F1	DC-1.5	56	66	—	dB
		F1-F2	1.5-3.0	40	49	—	
		F2-F3	3.0-4.0	20	28	—	
	Freq. Cut-Off <sup>4</sup>	F <sub>c</sub>	5	—	3	—	dB

1. Tested in Evaluation Board P/N TB-HFHKI-5000C+.

2. This filter is bi-directional RF1 and RF2 ports may be interchanged, see S-Parameters for actual performance.

3. This component should not be used as a DC-block. In applications where DC voltage and/or current is present at either the input or output ports, external DC blocking capacitors are required.

4. Typical variation ± 5%

### ABSOLUTE MAXIMUM RATINGS<sup>5</sup>

Operating Temperature	-55 °C to +125 °C
Storage Temperature	-55 °C to +125 °C
Input Power <sup>6</sup>	6 W

5. Permanent damage may occur if any of these limits are exceeded.

6. Power rating applies only to signals within the passband. Power rating above +25 °C operating temperature decreases linearly to 1 W at +125°C.

### TYPICAL FREQUENCY RESPONSE

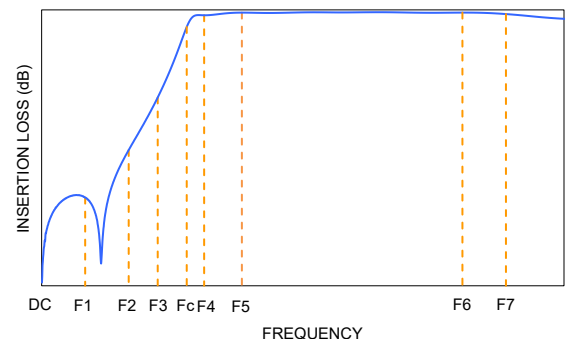



LTCC SURFACE MOUNT

# High Pass Filter

## HFHKI-5000+

Mini-Circuits

50Ω 5.6 to 16 GHz

### TYPICAL PERFORMANCE GRAPHS

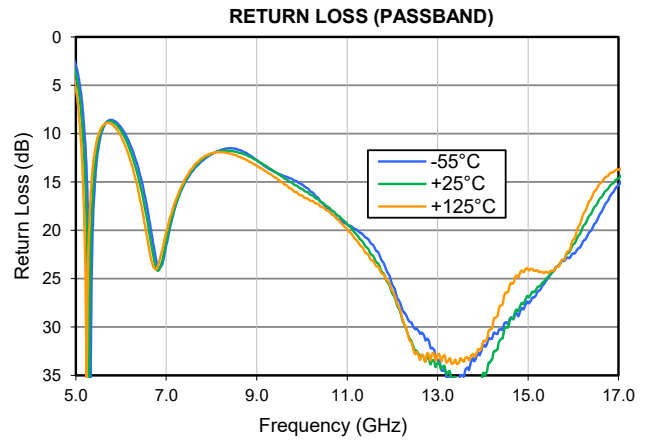
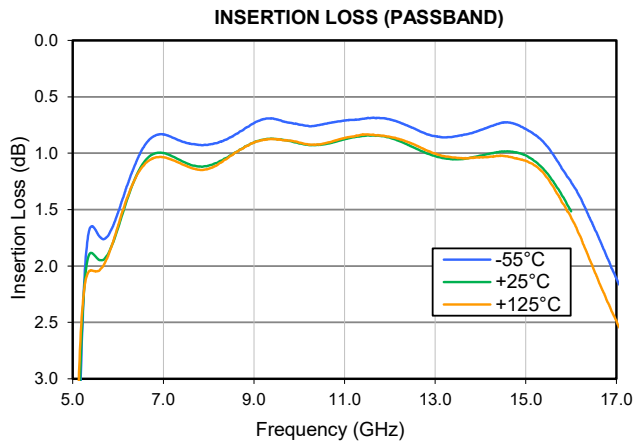
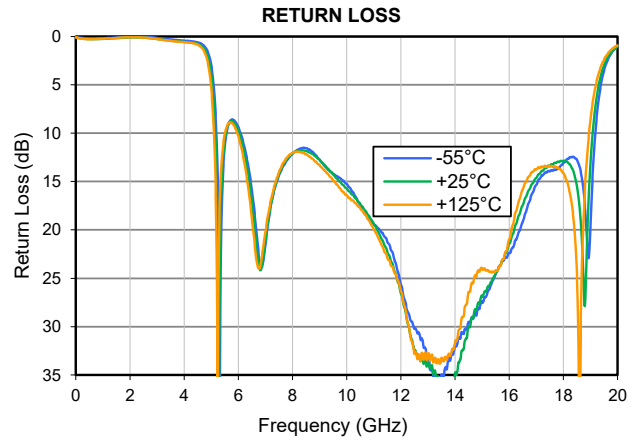
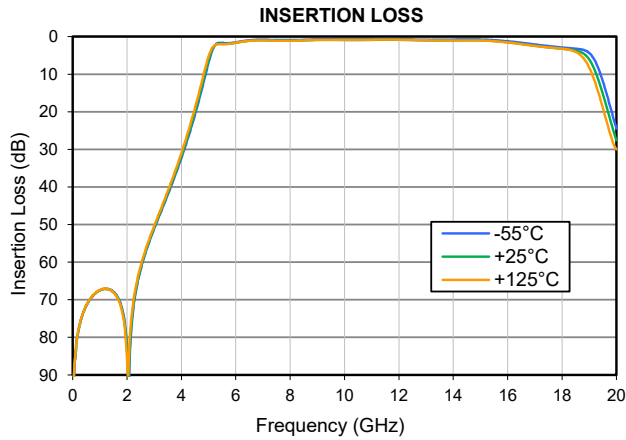



LTCC SURFACE MOUNT

# High Pass Filter

# HFHKI-5000+

Mini-Circuits

50Ω 5.6 to 16 GHz

### FUNCTIONAL DIAGRAM

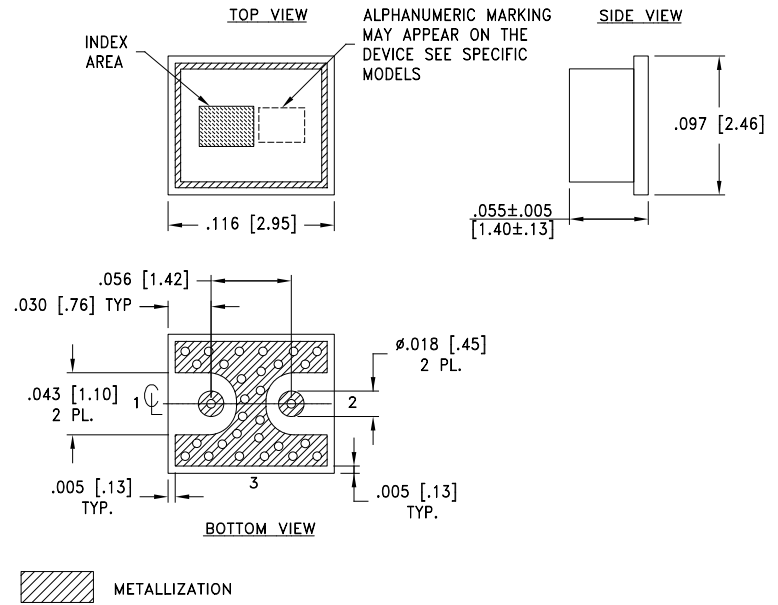

Figure 1. HFHKI-5000+ Functional Diagram

### PAD DESCRIPTION

Function	Pad Number	Description
RF1	1	Connects to RF Input Port
RF2	2	Connects to RF Output Port
GROUND	3	Connects to Ground on PCB, (See drawing PL-837)

### CASE STYLE DRAWING



Weight: .021 grams  
Dimensions are in inches [mm]. Tolerances: 2 Pl. ±.01; 3 Pl. ±.005 Inches

### SUGGESTED PCB LAYOUT (PL-837)

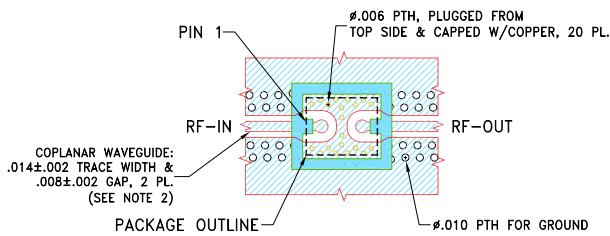

#### STACK-UP DIAGRAM

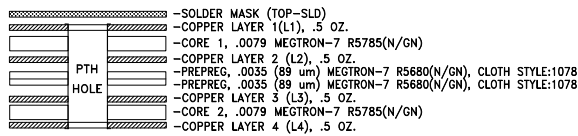

- TOTAL FINISHED THICKNESS 0.026±.004.
- PTH PRESENT FROM COPPER LAYER 1 TO COPPER LAYER 4.
- INDICATED ON TOP VIEW PTH'S ARE PLUGGED WITH EPOXY AND CAPPED WITH COPPER FROM TOP SIDE.
- L2, L3, AND L4 ARE CONTINUOUS GROUND PLANES.

#### NOTES:

- PCB IS MULTILAYER PCB, SEE STACK-UP DIAGRAM.
- TRACE WIDTH & GAP ARE SHOWN FOR MEGTRON-7 R5785(N/GN) WITH DIELECTRIC THICKNESS .0079". COPPER: .5 OZ. EACH LAYER. FOR OTHER MATERIALS TRACE WIDTH & GAP MAY NEED TO BE MODIFIED.
- LAYERS L2, L3 & L4 OF PCB ARE CONTINUOUS GROUND PLANES.

- DENOTES PCB COPPER LAYOUT WITH SMOBC (SOLDER MASK OVER BARE COPPER).
- DENOTES COPPER LAND PATTERN FREE OF SOLDER MASK.

Figure 2. Suggested PCB Layout

### PRODUCT MARKING\*: R9

\*Marking may contain other features or characters for internal lot control.



LTCC SURFACE MOUNT

# High Pass Filter

## HFHKI-5000+

50Ω 5.6 to 16 GHz

ADDITIONAL DETAILED INFORMATION IS AVAILABLE ON OUR DASHBOARD

[CLICK HERE](#)

Performance Data & Graphs	Data Graphs S-Parameter (S2P Files) Data Set (.zip file) De-embedded to device pads
Case Style	NM3723-1 Lead Finish: Gold Plate over Nickel Plate
RoHS/REACH Status	Compliant
Tape and Reel	F66-3
Suggested Layout for PCB Design	PL-837
Evaluation Board	TB-HFHKI-5000C+ Gerber File
Environmental Rating	ENV06T10

### NOTES

- A. Performance and quality attributes and conditions not expressly stated in this specification document are intended to be excluded and do not form a part of this specification document.
- B. Electrical specifications and performance data contained in this specification document are based on Mini-Circuits' applicable established test performance criteria and measurement instructions.
- C. The parts covered by this specification document are subject to Mini-Circuits' standard limited warranty and terms and conditions (collectively, "Standard Terms"); Purchasers of this part are entitled to the rights and benefits contained therein. For a full statement of the standard terms and the exclusive rights and remedies thereunder, please visit Mini-Circuits' website at [www.minicircuits.com/terms/viewterm.html](http://www.minicircuits.com/terms/viewterm.html)

