



LTCC SURFACE MOUNT

High Pass Filter

HFHKI-3100+

50Ω 3500 to 12500 MHz

THE BIG DEAL

- Insertion Loss, Typ. 1 dB
- Strong Stopband Rejection
- Ultra-Wide Passband, 3500 to 12500 MHz
- 1210 SMT Footprint
- Integrated CPWG Interposer for Easy SMT Integration
- Power Handling: 6 W
- Protected by US Patents 11,638,370 and 11,744,057

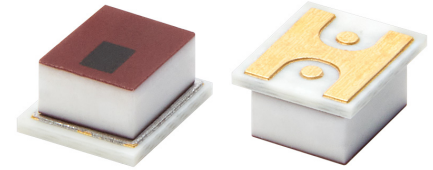

Generic photo used for illustration purposes only

APPLICATIONS

- 5G Sub-6 GHz and Emerging Mid-band systems
- X-Band Radar Systems
- Test and Measurement Equipment
- Ultra-Wideband (UWB) Systems
- Satellite Communications

FUNCTIONAL DIAGRAM

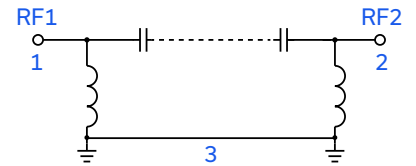

PRODUCT OVERVIEW

The HFHKI-3100+ is a 3500 to 12500 MHz LTCC high pass filter incorporating an integrated interposer for CPWG interface capability. The architecture enables direct connection to planar transmission lines. The filter provides broad passband performance with effective suppression of signals below cutoff. Its SMT implementation supports compact layouts, and the ceramic construction maintains consistent electrical behavior across environmental conditions.

ELECTRICAL SPECIFICATIONS^{1,2,3} AT +25 °C, Z₀ = 50 Ω

| Parameter | | F# | Frequency (MHz) | Min. | Typ. | Max. | Units |
|-----------|----------------------------|----------------|-----------------|------|------|------|-------|
| Passband | Insertion Loss | F4-F5 | 3500-5000 | — | 1.8 | 2.4 | dB |
| | | F5-F6 | 5000-10500 | — | 1 | 1.6 | |
| | | F6-F7 | 10500-12500 | — | 1.3 | 2.6 | |
| Passband | Return Loss | F4-F5 | 3500-5000 | — | 11 | — | dB |
| | | F5-F6 | 5000-10500 | — | 13 | — | |
| | | F6-F7 | 10500-12500 | — | 13 | — | |
| Stopband | Rejection | DC-F1 | DC-950 | 60 | 70 | — | dB |
| | | F1-F2 | 950-1700 | 37 | 47 | — | |
| | F2-F3 | 1700-2400 | — | 23 | — | | |
| Stopband | Freq. Cut-Off ⁴ | F _c | 3175 | — | 3 | — | dB |

1. Tested on Evaluation Board P/N TB-HFHKI-3100C+ with the connector and feedline effects de-embedded using the 2X Thru IEEE P370 method.
2. This filter is bi-directional RF1 and RF2 ports may be interchanged, see S-Parameters for actual performance.
3. This component should not be used as a DC-block. In applications where DC voltage and/or current is present at either the input or output ports, external DC blocking capacitors are required.
4. Typical variation ± 5 %

ABSOLUTE MAXIMUM RATINGS⁵

| | |
|--------------------------|-------------------|
| Operating Temperature | -55 °C to +125 °C |
| Storage Temperature | -55 °C to +125 °C |
| Input Power ⁶ | 6 W at 25 °C |

5. Permanent damage may occur if any of these limits are exceeded.
6. Power rating applies only to signals within the passband. Power rating above +25°C operating temperature decreases linearly to 1 W at +125°C.

TYPICAL FREQUENCY RESPONSE

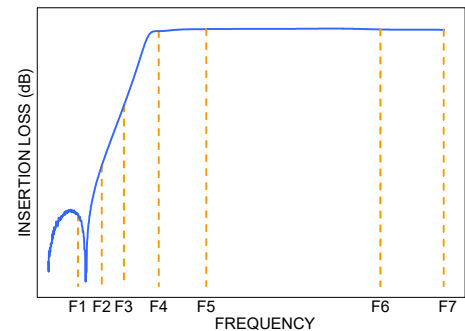



LTCC SURFACE MOUNT

High Pass Filter

HFHKI-3100+

Mini-Circuits

50Ω 3500 to 12500 MHz

TYPICAL PERFORMANCE GRAPHS

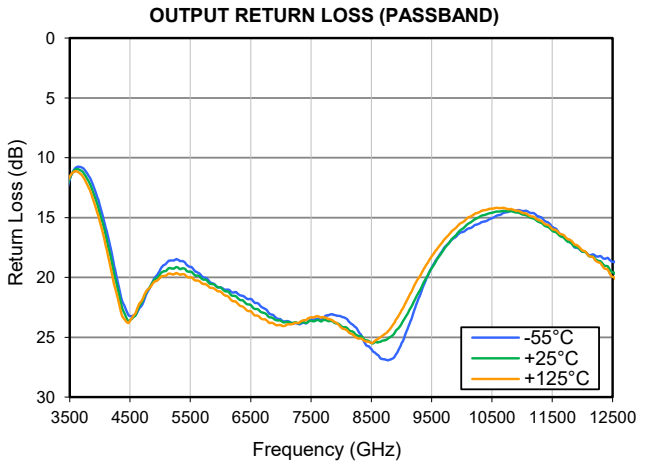
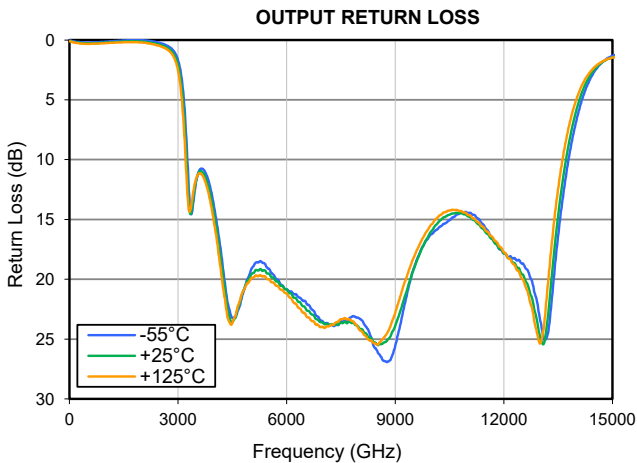
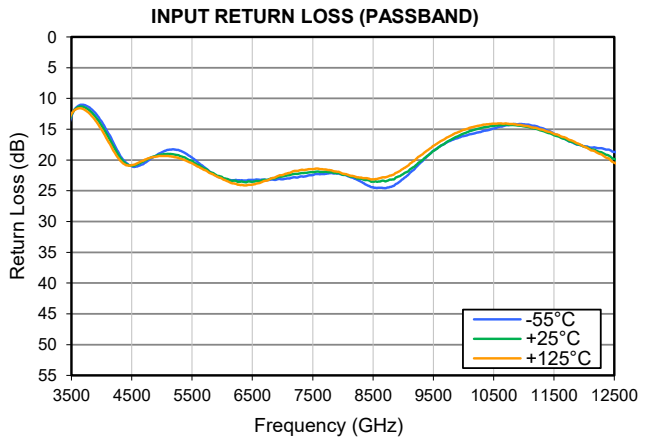
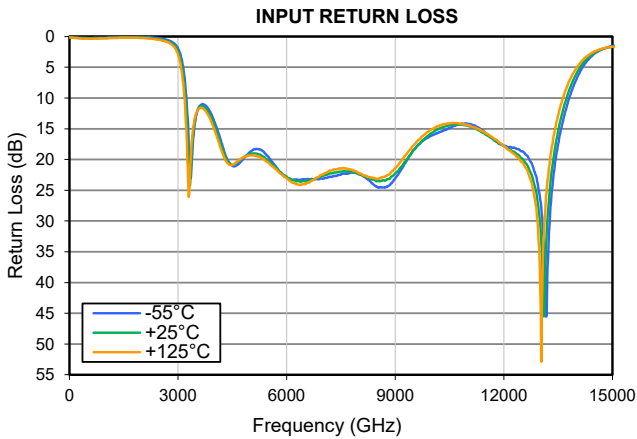
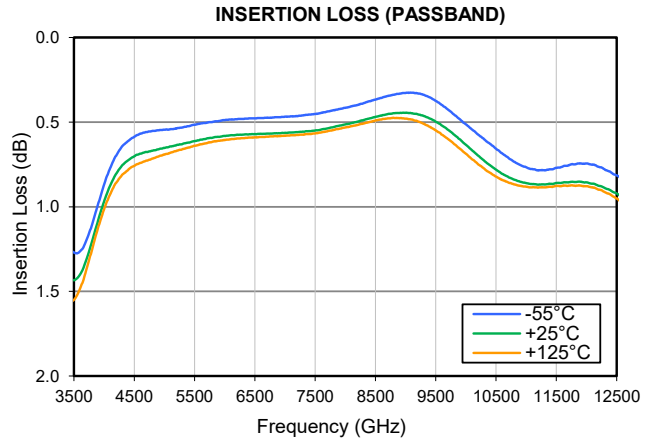
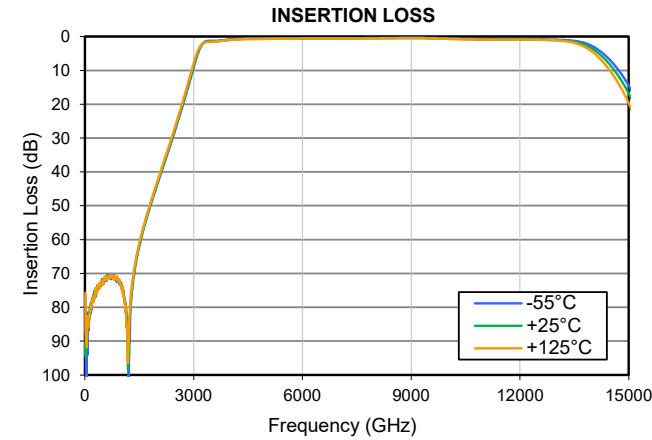



LTCC SURFACE MOUNT

High Pass Filter

HFHKI-3100+

Mini-Circuits

50Ω 3500 to 12500 MHz

FUNCTIONAL DIAGRAM

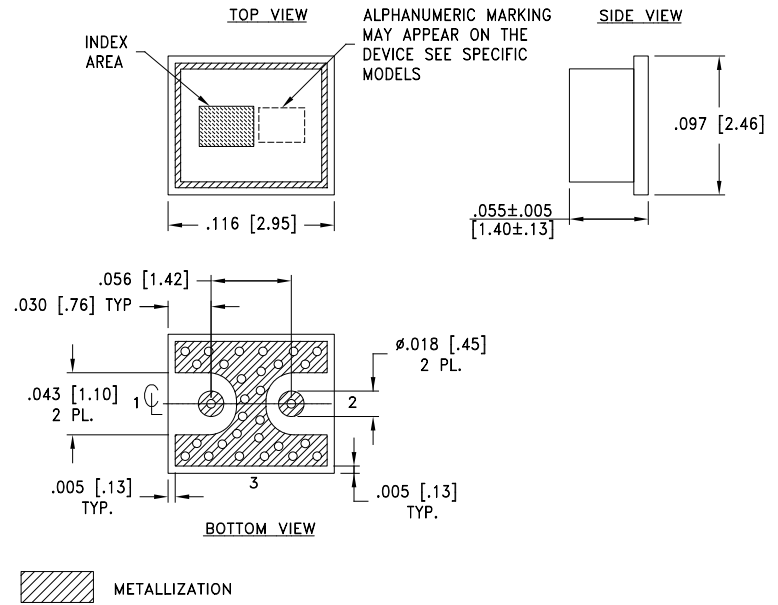

Figure 1. HFHKI-3100+ Functional Diagram

PAD DESCRIPTION

| Function | Pad Number | Description |
|------------------|------------|-------------------------------------------------|
| RF1 ² | 1 | Connects to RF Input Port |
| RF2 ² | 2 | Connects to RF Output Port |
| GROUND | 3 | Connects to Ground on PCB, (See drawing PL-837) |

CASE STYLE DRAWING



Weight: .021 grams
Dimensions are in inches [mm]. Tolerances: 2 Pl. ±.01; 3 Pl. ±.005 Inches

SUGGESTED PCB LAYOUT (PL-837)

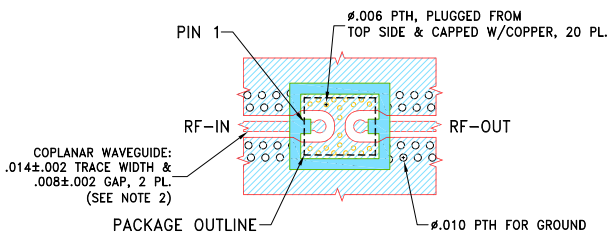

STACK-UP DIAGRAM

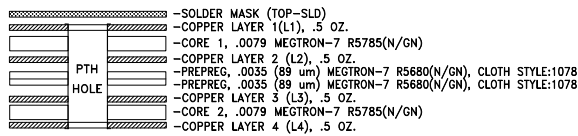

- TOTAL FINISHED THICKNESS 0.026±.004.
- PTH PRESENT FROM COPPER LAYER 1 TO COPPER LAYER 4.
- INDICATED ON TOP VIEW PTH'S ARE PLUGGED WITH EPOXY AND CAPPED WITH COPPER FROM TOP SIDE.
- L2, L3, AND L4 ARE CONTINUOUS GROUND PLANES.

NOTES:

- PCB IS MULTILAYER PCB, SEE STACK-UP DIAGRAM.
- TRACE WIDTH & GAP ARE SHOWN FOR MEGTRON-7 R5785(N/GN) WITH DIELECTRIC THICKNESS .0079". COPPER: .5 OZ. EACH LAYER. FOR OTHER MATERIALS TRACE WIDTH & GAP MAY NEED TO BE MODIFIED.
- LAYERS L2, L3 & L4 OF PCB ARE CONTINUOUS GROUND PLANES.

- DENOTES PCB COPPER LAYOUT WITH SMOBC (SOLDER MASK OVER BARE COPPER).
- DENOTES COPPER LAND PATTERN FREE OF SOLDER MASK.

PRODUCT MARKING*: K6

*Marking may contain other features or characters for internal lot control.

Figure 2. Suggested PCB Layout



LTCC SURFACE MOUNT

High Pass Filter

HFHKI-3100+

50Ω 3500 to 12500 MHz

ADDITIONAL DETAILED INFORMATION IS AVAILABLE ON OUR DASHBOARD

[CLICK HERE](#)

| | |
|----------------------------------------|-------------------------------------------------------------------------------------------|
| Performance Data & Graphs | Data Graphs S-Parameter (S2P Files) Data Set (.zip file) De-embedded to device pads |
| Case Style | NM3723-1 Lead Finish: Gold Plate over Nickel Plate |
| RoHS/REACH Status | Compliant |
| Tape and Reel | F66-3 |
| Suggested Layout for PCB Design | PL-837 |
| Evaluation Board | TB-HFHKI-3100C+ Gerber File |
| Environmental Rating | ENV06T10 |

NOTES

- A. Performance and quality attributes and conditions not expressly stated in this specification document are intended to be excluded and do not form a part of this specification document.
- B. Electrical specifications and performance data contained in this specification document are based on Mini-Circuits' applicable established test performance criteria and measurement instructions.
- C. The parts covered by this specification document are subject to Mini-Circuits' standard limited warranty and terms and conditions (collectively, "Standard Terms"); Purchasers of this part are entitled to the rights and benefits contained therein. For a full statement of the standard terms and the exclusive rights and remedies thereunder, please visit Mini-Circuits' website at www.minicircuits.com/terms/viewterm.html

