



STRIPLINE SURFACE MOUNT

Bi-Directional Coupler

BDCH-20-63+

50Ω 2000 to 6000 MHz 20 dB 180W

KEY FEATURES

- High power handling, up to 180W
- Ultra wideband, 2000 to 6000 MHz
- Low insertion loss, 0.15 dB

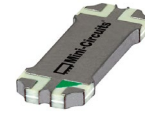

Generic photo used for illustration purposes only

APPLICATIONS

- Power amplifiers
- Antenna feeds
- Mobile satellite communication
- Digital communication applications

FUNCTIONAL DIAGRAM

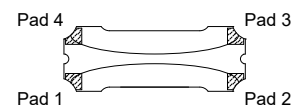

PRODUCT OVERVIEW

Mini-Circuits' BDCH-20-63+ is a high-power bi-directional coupler providing high power handling up to 180W and mainline loss of 0.15 dB. Covering frequencies from 2000 to 6000 MHz, the model supports a wide variety of applications from power amplifiers and antenna feeds to various digital communications and more. High directivity of 19 dB provides accurate sampling from the coupled port, and 20 dB return loss provides excellent matching over full frequency range. The coupler is designed into an open printed laminate (0.56" x 0.20" x 0.051") with wrap-around terminations for good solderability and easy visual inspection.

ELECTRICAL SPECIFICATIONS^{1,2} AT +25°C

Parameter	Frequency (MHz)	Min.	Typ.	Max.	Units
Frequency Range		2000		6000	MHz
Mainline Loss ³	2000 - 6000	-	0.15	0.30	dB
Coupling Nominal	2000 - 6000	-	20±1.5	-	dB
Coupling Flatness (±)	2000 - 6000	-	±1.7	-	dB
Directivity	2000 - 6000	15.5	19	-	dB
Return Loss (Input/Output)	2000 - 6000	16	20	-	dB
Return Loss (Coupled Forward/Reverse)	2000 - 6000	16	20	-	dB
Thermal Resistance ⁴	2000 - 6000	-	0.25	-	°C/W

1. Tested on Evaluation Board TB-864+. De-embedded to the device reference plane.

2. Model is symmetrical and all ports are interchangeable, see Port Function Description/Configuration table for details and S-Parameters for actual performance.

3. Does not include theoretical loss due to coupling. Nominal theoretical loss is 0.05 dB.

4. Thermal Resistance is defined as, example (θ_{jc})= (Hot Spot Temperature on DUT - Base Plate Temperature)/Input Power)

ABSOLUTE MAXIMUM RATINGS⁵

Operating Case Temperature ⁶	-55 °C to +105 °C	
Storage Temperature	-55 °C to +105 °C	
Power Input	+85 °C case	180 W
	+95 °C case	130 W
	+105 °C case	100 W
DC Current	2 A	

5. Permanent damage may occur if any of these limits are exceeded.

6. Case temperature is defined as temperature on base plate.





TYPICAL PERFORMANCE GRAPHS

* Data corresponds to Configuration A at +25°C unless specified otherwise.

BDCH-20-63+

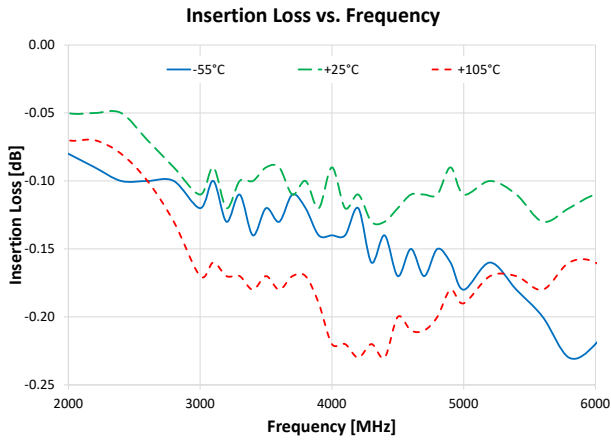

BDCH-20-63+

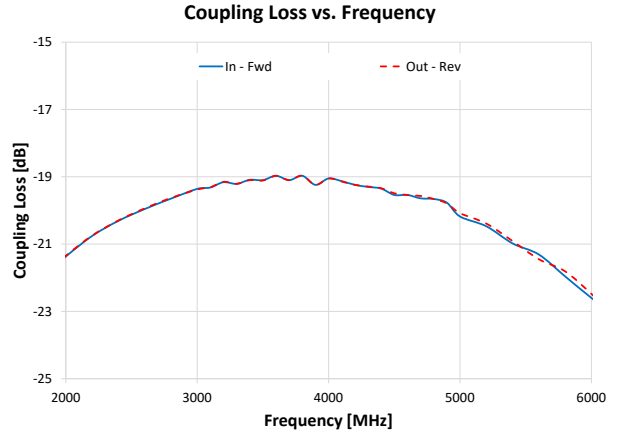

BDCH-20-63+

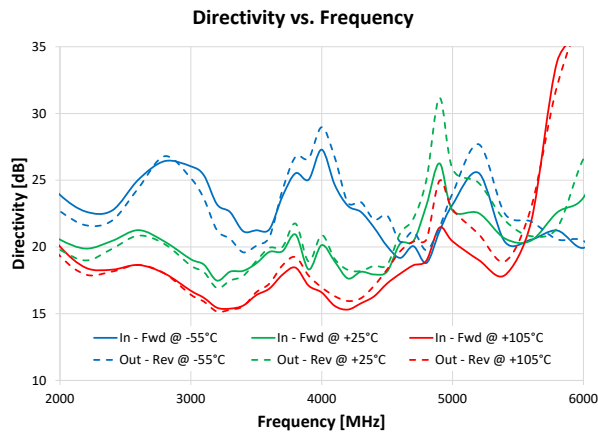

BDCH-20-63+

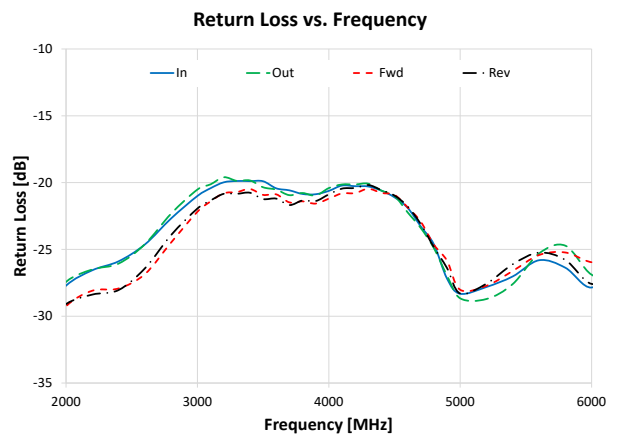



FUNCTIONAL DIAGRAM

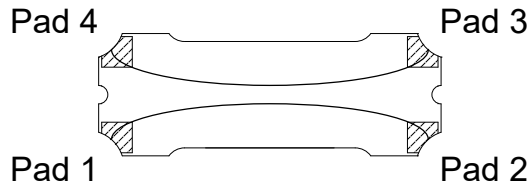

Figure 1. BDCH-20-63+ Functional Diagram

PAD DESCRIPTION/CONFIGURATION⁷

Function	Pad Number	Description
Input	1	Connects to RF Input Port
Output	2	Connects to RF Output Port
Coupled Forward	4	Connects to Coupled Forward Port
Coupled Reverse	3	Connects to Coupled Reverse Port
Ground	5	Connects to Ground

Configuration	Input	Output	Coupled Forward	Coupled Reverse
A	1	2	4	3
B	2	1	3	4
C	3	4	2	1
D	4	3	1	2

7. Model is symmetrical and all ports are interchangeable, see Port Function Description/Configuration table for details and S-Parameters for actual performance.

SUGGESTED PCB LAYOUT (PL-470)

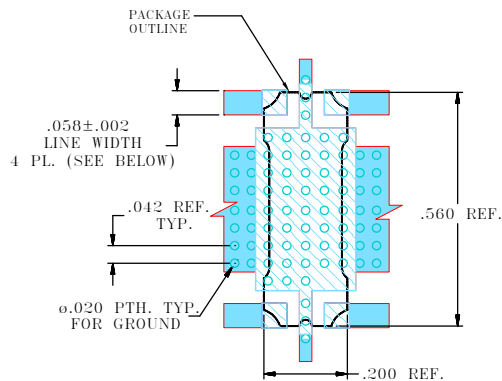

- NOTES:
1. TRACE WIDTH IS SHOWN FOR ROGERS R05880 WITH DIELECTRIC THICKNESS, 0.020"±.0015". COPPER: 1 OZ. EACH SIDE. FOR OTHER MATERIALS TRACE WIDTH MAY NEED TO BE MODIFIED.
 2. BOTTOM SIDE OF THE PCB IS CONTINUOUS GROUND PLANE.
- DENOTES PCB COPPER LAYOUT WITH SMOBC (SOLDER MASK OVER BARE COPPER)
 DENOTES COPPER LAND PATTERN FREE OF SOLDERMASK

Figure 2. Suggested PCB Layout PL-470

CASE STYLE DRAWING (PQ2099)

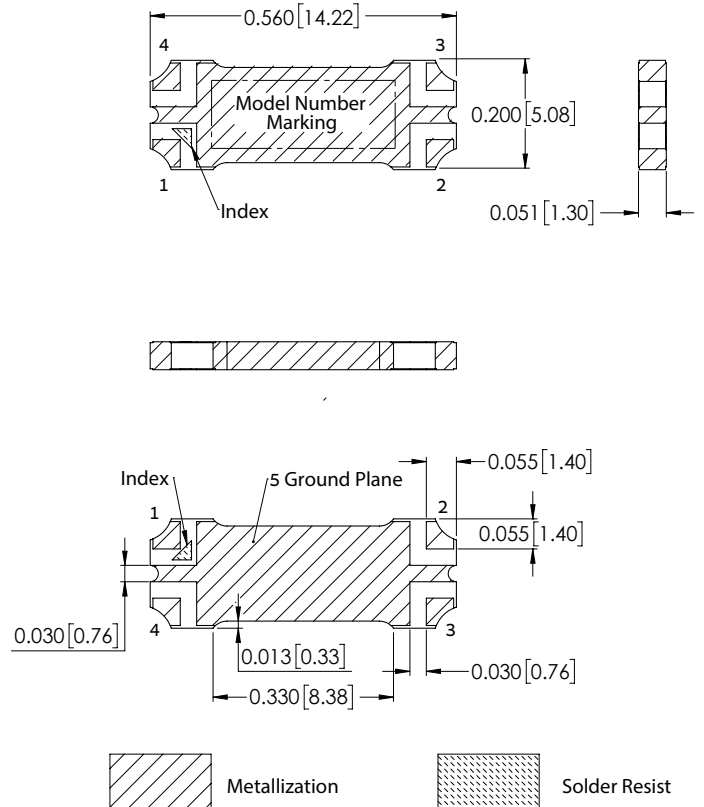

NOTES:

1. Base material: Printed wiring laminate.
2. Termination finish: 2-5 μinch (.05-.13 microns) Immersion Gold.
3. Weight: 1.5 grams
4. Marking may contain other features or characters for internal lot control.

PRODUCT MARKING*: BDCH-20-63+

*Marking may contain other features or characters for internal lot control.



STRIPLINE SURFACE MOUNT

Bi-Directional Coupler

BDCH-20-63+

50Ω 2000 to 6000 MHz 20 dB 180W

ADDITIONAL DETAILED INFORMATION IS AVAILABLE ON OUR DASH BOARD.

[CLICK HERE](#)

Performance Data & Graphs	Data
	Graphs
	S-Parameter (S4P Files) Data Set (.zip file) De-embedded to device pads
Case Style	PQ2099 Lead Finish: 2-5 inch (0.05-0.13 microns) Immersion Gold.
RoHS Status	Compliant
Tape and Reel	F48
Suggested Layout for PCB Design	PL-470
Evaluation Board	TB-864+
	Gerber File
Environmental Rating	ENV02T8

NOTES

- A. Performance and quality attributes and conditions not expressly stated in this specification document are intended to be excluded and do not form a part of this specification document.
- B. Electrical specifications and performance data contained in this specification document are based on Mini-Circuits' applicable established test performance criteria and measurement instructions.
- C. The parts covered by this specification document are subject to Mini-Circuits' standard limited warranty and terms and conditions (collectively, "Standard Terms"); Purchasers of this part are entitled to the rights and benefits contained therein. For a full statement of the standard terms and the exclusive rights and remedies thereunder, please visit Mini-Circuits' website at www.minicircuits.com/terms/viewterm.html

