

Evaluation Board and Circuit

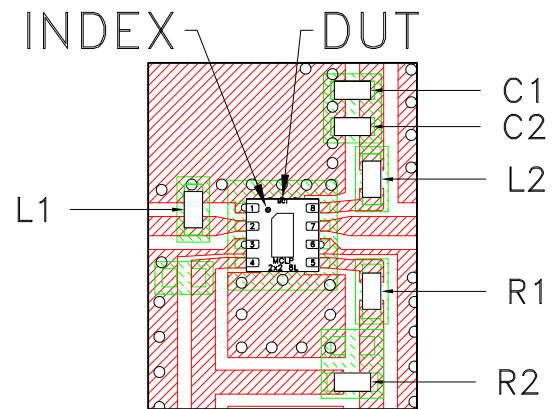

DETAIL "A"
LOCATION OF COMPONENTS
ON THE PCB
(SCALE 3:1)

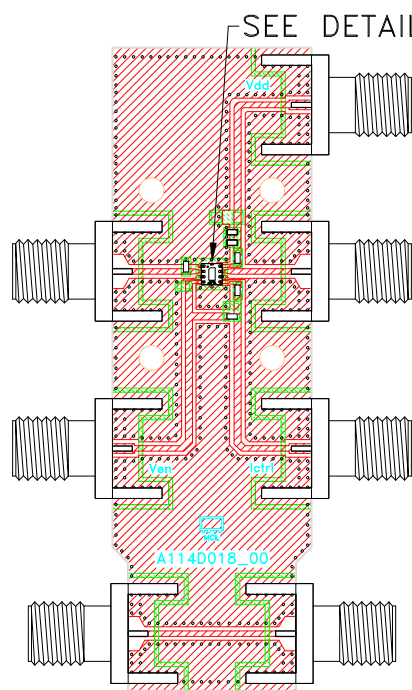
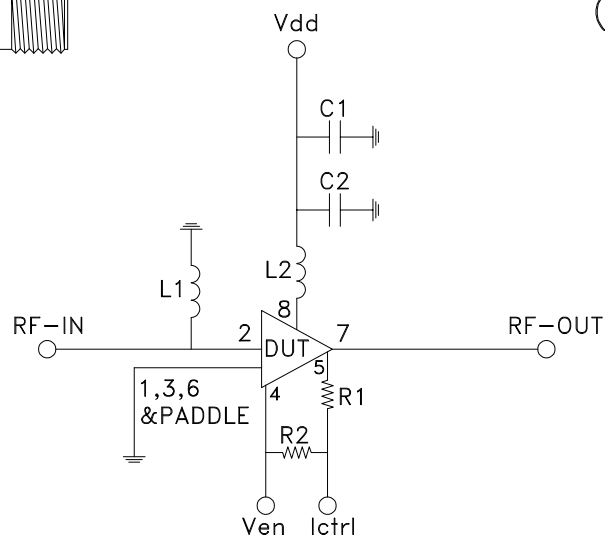

SCHEMATIC DIAGRAM

Component	Size	Value	Part Number	Manufacturer
C1	0402	0.1uF	GRM155R71C104KA88D	Murata
C2	0402	10pF	GJM1555C1H100JB01D	Murata
L1	0402	47nH	LQG15WH47NJ02D	Murata
L2	0402	56nH	0402HPH-56NXGRW	Coilcraft
R1	0402	00hm	RK73Z1ETTP	KOA Speer
R2	0402	3.92K0hm	RK73H1ETTP3921F	KOA Speer

Notes:

1. 50 Ohm SMA Female Connectors.
2. PCB Material: Roger R04350B or equivalent,
Dielectric constant=3.5, Thickness=0.010 inch

 Mini-Circuits®