

# Evaluation Board and Circuit

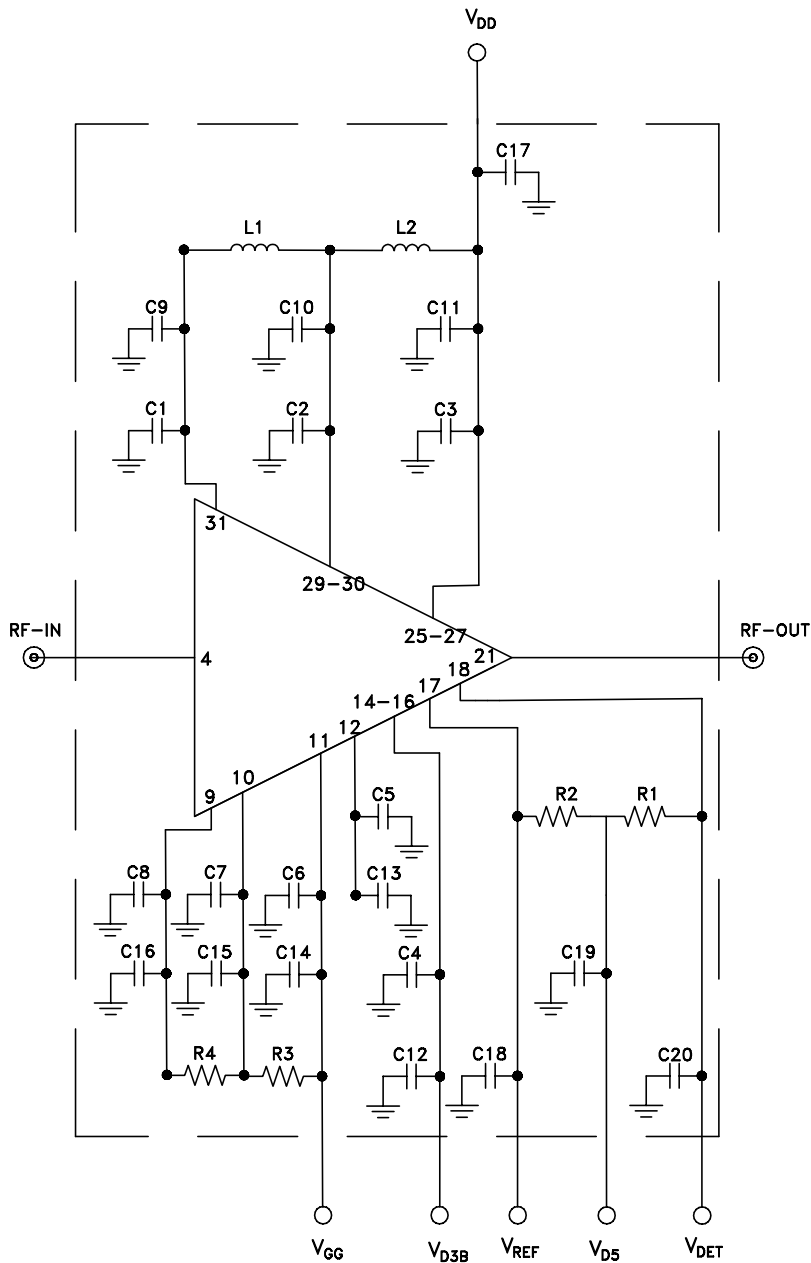

SCHMATIC DIAGRAM

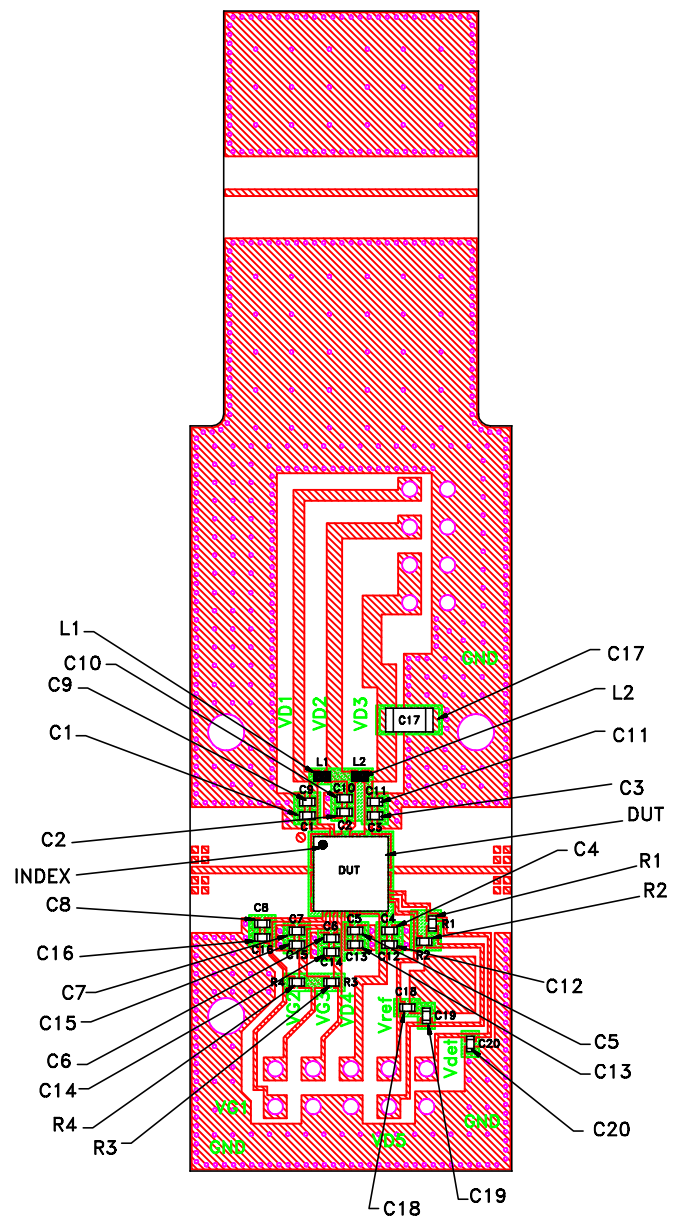

DETAIL "C"

LOCATION OF INTERCONNECTOR AND UNITS COMPONENTS

Component	Size	Value	PartNumber	Manufacturer
R1-R2	0402	100KΩ	RK73H1ETTP1003F	KOA SPEER ELECTRONICS
R3	0402	0Ω	RK73Z1ETTP	KOA SPEER ELECTRONICS
R4	0402	100Ω	RK73H1ETTP1000F	KOA SPEER ELECTRONICS
C1-C8	0402	0.001μF	GRM1555C1H102JA01D	MURATA
C9-C16,C18-C20	0402	0.1μF	GRM155R71E104KE14D	MURATA
C17	1206	47μF	1206YD476MAT2A	AVX CORPORATION
L1,L2	0402	150nH	0402DF-151XJRW	COILCRAFT

**Notes:**

- 2.92mm Female Connectors.
- PCB Material: Roger R04003C LOPRO or equivalent, Thickness=0.0087±.001 inch

