

Evaluation Board and Circuit

TB-CBP2-1090C+

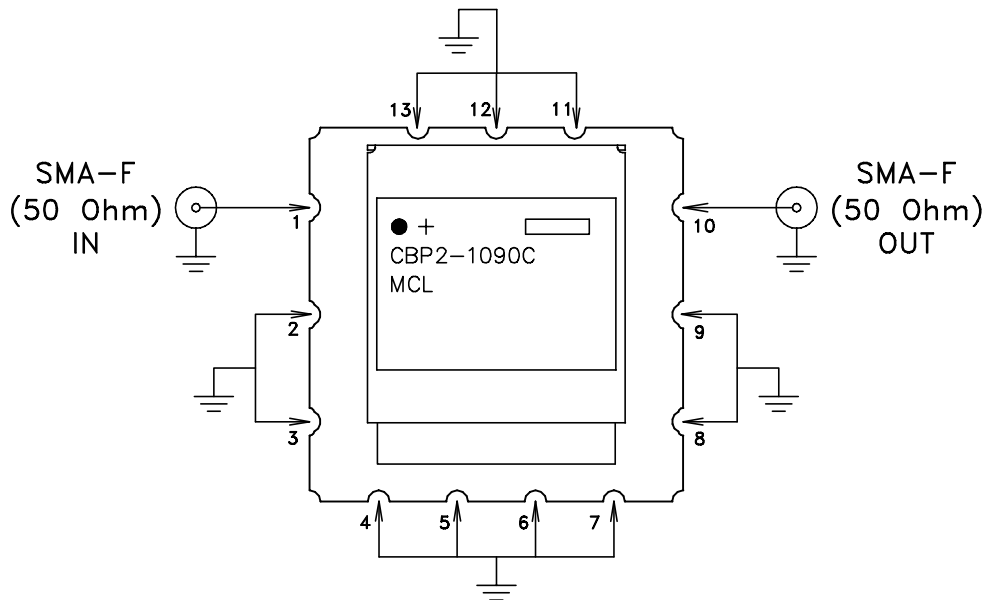
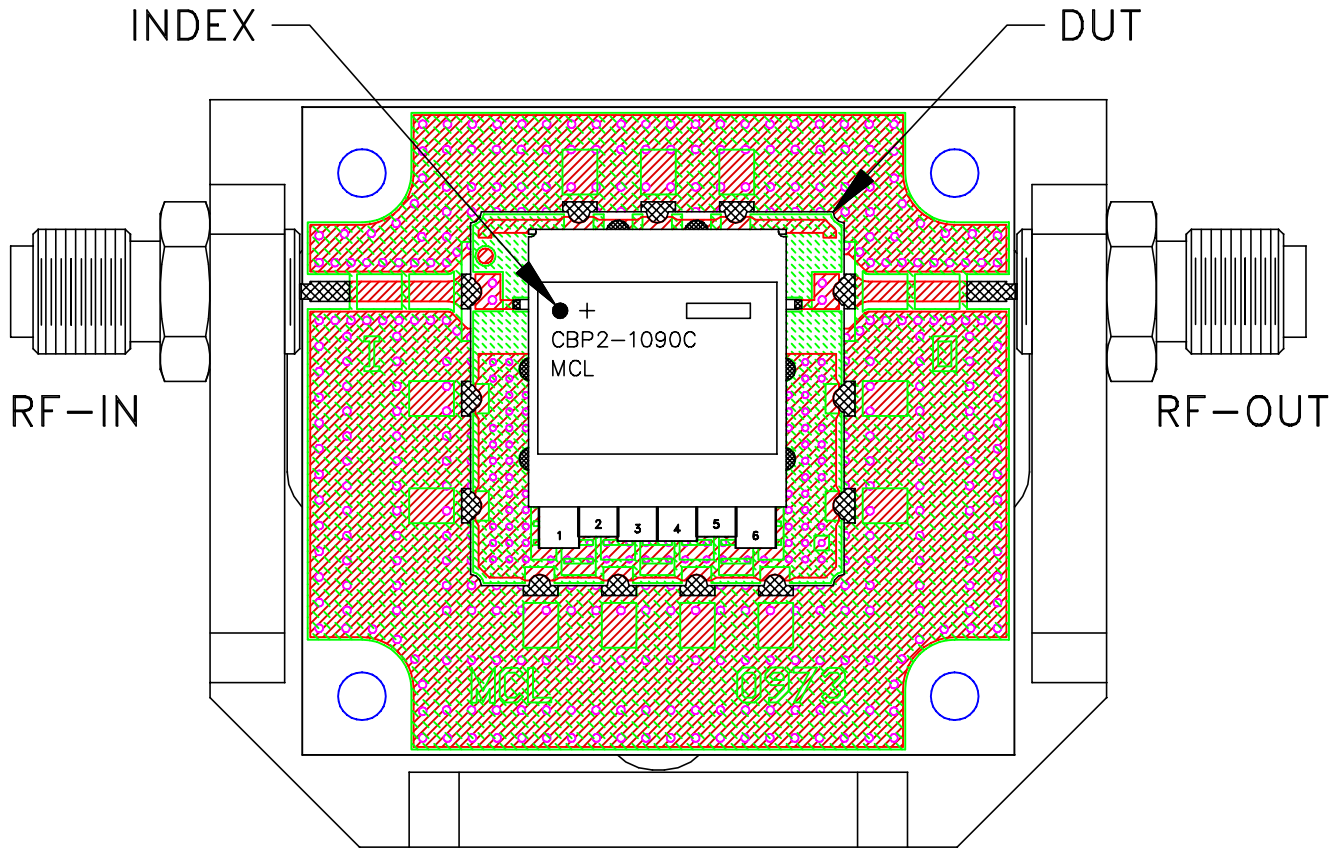

Schematic diagram

Notes:

1. 50 Ohm SMA female connectors.
2. PCB Material: ROGERS (R04350B) OR Equivalent
Dielectric Constant=3.48, Thickness=.020 inch.

