

DISPENCE SOLDER PASTE
4 PLACES

MCP-104362

DISPENCE SOLDER PASTE
3 PLACES

MCP-104362

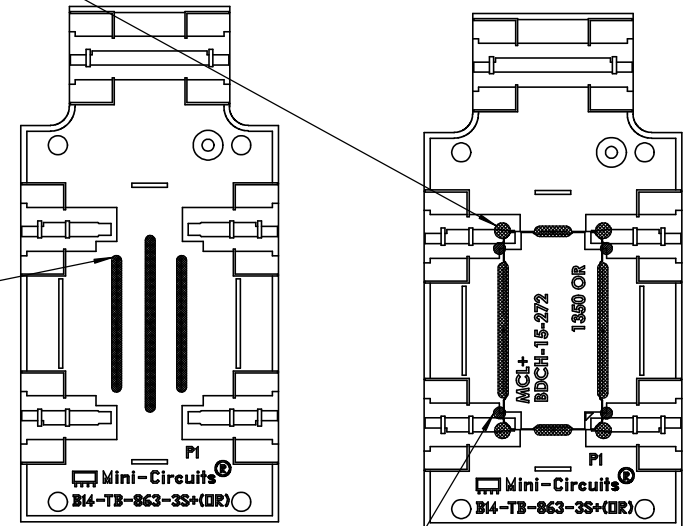

DISPENCE RTV
4 PLACES

MCP-7987

ASSEMBLY NOTES:

- DISPENCE SOLDER PASTE ON PCB ACCORDING TO DRAWING.
- REFLOW LdFr-245-UUH-ZXC PROGRAM WITH SMALL JIG FIXTURE.

ITEM NO.	PART NUMBER	DESCRIPTION	QTY.
1	BDCH-15-272+	BI DIR COUP / SURF MT / RoHS	1
2	B14-TB-863-3S+	PCB RO4003C 2.6X1.3X.032 GS266	1
3	B20-14-F34+	CONN SMA-F END LAUNCH A .089"	6
4	B18-JB-001+	WASHER SPLIT LOCK #2 ROHS	8
5	B18-HB-002+	WASHER FL#2 OD.187/ID.096 RoHS	8
6	B85-TS-537+	SPACER 2.60 X1.30 X.20 BRASS	1
7	B18-DB-038+	SCREW PAN HD #2-56 3/8"LG ROHS	8
8	B13-3902-1+	HTSK, BLK ANDZ 3.00X2.60X1.00	1
9	B16-10-53+	SIL THRM LBL .60X 1.10 RoHS	1

UNLESS OTHERWISE SPECIFIED		INITIALS	DATE	MODEL:			
DIMENSIONS ARE IN INCHES (MM)		DRAWN	13 Jan 2025	TB-BDCH-15-272+			
TOLERANCES ON:		CHECKED	13 Jan 2025				
2 PL DECIMALS ± .01	63	APPROVED	13 Jan 2025	ASSEMBLY DRAWING EVALUATION BOARD FOR TB-BDCH-15-272+			
3 PL DECIMALS ± .005							
ANGLES ± 1°							
FRACTIONS ± 1/32"				SIZE	CODE IDENT	DRAWING NO.	REV:
				B	15542	IL-0433-20	A0
				FILE:	SCALE:	SHEET:	
<small>THIS DOCUMENT AND ITS CONTENTS ARE THE PROPERTY OF MINI-CIRCUITS ISRAEL LTD. EXCEPT FOR USE EXPRESSLY GRANTED, IN WRITING, TO ITS VENDORS, VENDEE AND THE ISRAELI GOVERNMENT. MINI-CIRCUITS ISRAEL LTD RESERVES ALL PROPRIETARY DESIGN, USE, MANUFACTURING AND REPRODUCTION RIGHTS THERETO. THESE CONTENTS SHALL NOT BE USED, DUPLICATED OR DISCLOSED TO ANY OUTSIDE PARTY, IN WHOLE OR IN PART, WITHOUT WRITTEN PERMISSION OF MINI-CIRCUITS ISRAEL LTD.</small>				TB-BDCH-15-272 +(A0)	1:1	1 OF 4	

THIRD ANGLE PROJECTION

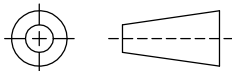

REV	ECO No.	DESCRIPTION	DATE	DR	AUTH
A0	ECO-024069	NEW RELEASE	13 JAN 2025	AL	PG
REVISIONS					

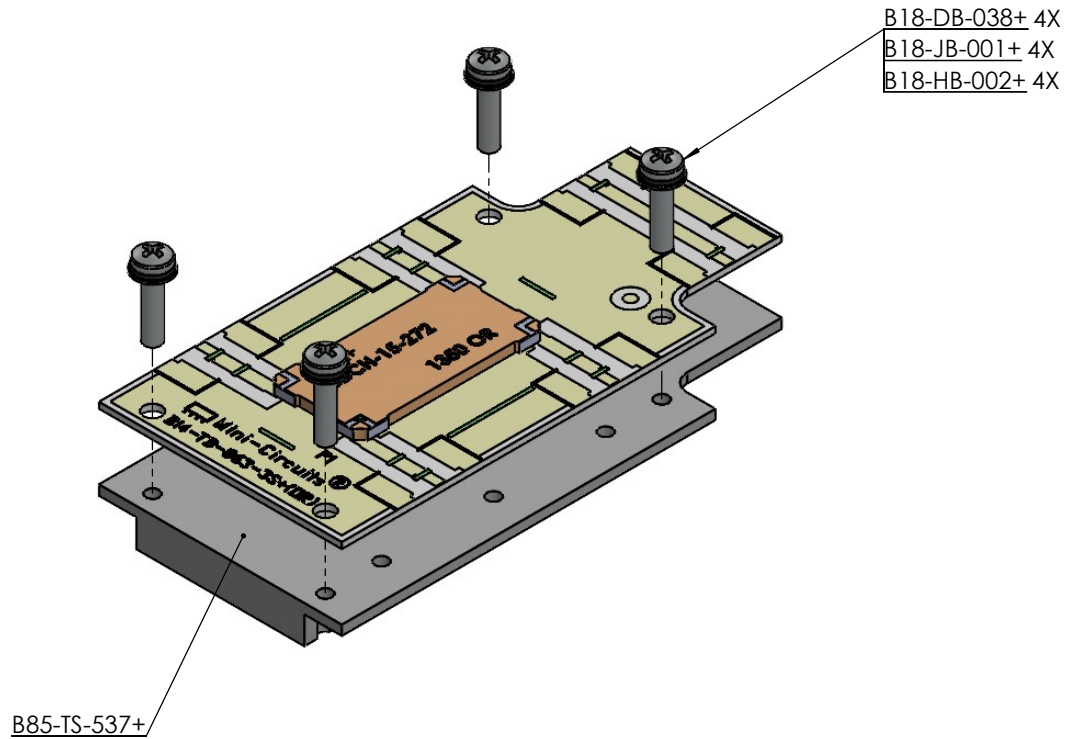

TOP VIEW SOLDER PASTE LOCATION ON PCB

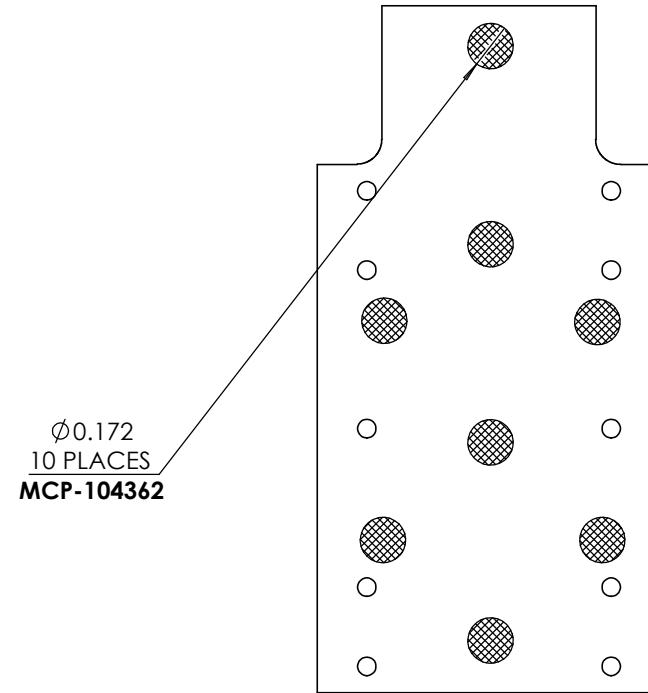

ASSEMBLY NOTES:

1. DISPENCE SOLDER DOTS AS SHOWN.
2. PUT PCB ON CARRIER.
3. IN ORER TO PREVENT MISALIGNMENT OF THE PCB USE SCREWS TO SECURE THE PCB.

Mini-Circuits Israel		ALL DIMENSIONS ARE IN INCHES EXCEPT OTHERWISE SPECIFIED			
THIS DOCUMENT AND ITS CONTENTS ARE THE PROPERTY OF MINI-CIRCUITS ISRAEL LTD. EXCEPT FOR USE EXPRESSLY GRANTED, IN WRITING, TO ITS VENDORS, VENDEE AND THE ISRAELI GOVERNMENT. MINI-CIRCUITS ISRAEL LTD RESERVES ALL PROPRIETARY DESIGN, USE, MANUFACTURING AND REPRODUCTION RIGHTS THERETO. THESE CONTENTS SHALL NOT BE USED, DUPLICATED OR DISCLOSED TO ANY OUTSIDE PARTY, IN WHOLE OR IN PART, WITHOUT WRITTEN PERMISSION OF MINI-CIRCUITS ISRAEL LTD.		SIZE B	CODE IDENT 15542	DRAWING NO: IL-0433-20	REV: A0
FILE: TB-BDCH-15-272 +(A0)		SCALE: 2:1	SHEET: 2 OF 4		

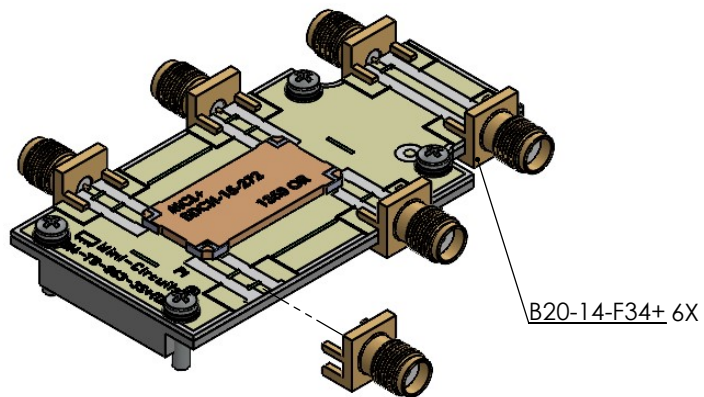

B20-14-F34+ 6X

MANUALLY SOLDER PINS
TO PCB 6 PLACES
MCP-5063

CONNECTOR

DETAIL A
SCALE 4:1

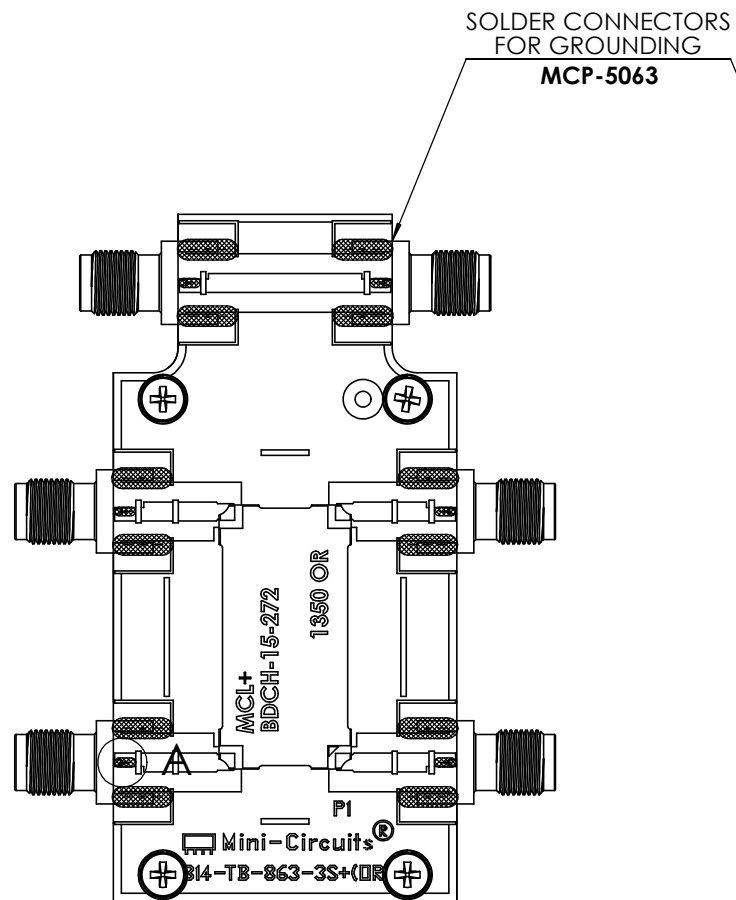
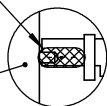

BOTTOM VIEW

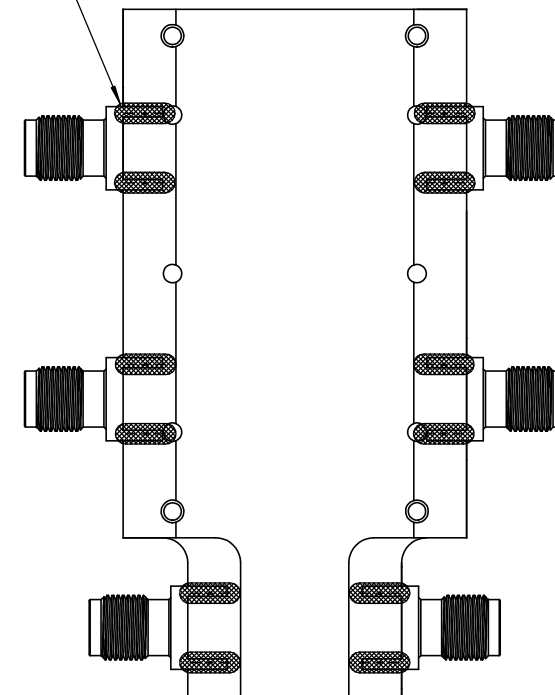

- ASSEMBLY NOTES:
TO PREVENT GAP BETWEEN CONNECTOR FORK AND PCB,
FOLLOW THESE ASSEMBLY STEPS:
1. SOLDER CONNECTOR FORK ON TOP SIDE OF PCB.
 2. SOLDER CONNECTOR FORK ON BOTTOM SIDE OF ASSEMBLY.
 3. SOLDER CONNECTOR CENTER PIN ON TOP SIDE OF PCB.

		ALL DIMENSIONS ARE IN INCHES EXCEPT OTHERWISE SPECIFIED		
<small>THIS DOCUMENT AND ITS CONTENTS ARE THE PROPERTY OF MINI-CIRCUITS ISRAEL LTD. EXCEPT FOR USE EXPRESSLY GRANTED, IN WRITING, TO ITS VENDORS, VENDEE AND THE ISRAELI GOVERNMENT, MINI-CIRCUITS ISRAEL LTD RESERVES ALL PROPRIETARY DESIGN, USE, MANUFACTURING AND REPRODUCTION RIGHTS THERETO. THESE CONTENTS SHALL NOT BE USED, DUPLICATED OR DISCLOSED TO ANY OUTSIDE PARTY, IN WHOLE OR IN PART, WITHOUT WRITTEN PERMISSION OF MINI-CIRCUITS ISRAEL LTD.</small>	<small>SIZE</small> B	<small>CODE IDENT</small> 15542	<small>DRAWING NO:</small> IL-0433-20	<small>REV:</small> A0
<small>FILE:</small> TB-BDCH-15-272 +(A0)	<small>SCALE:</small> 1:1	<small>SHEET:</small> 3 OF 4		

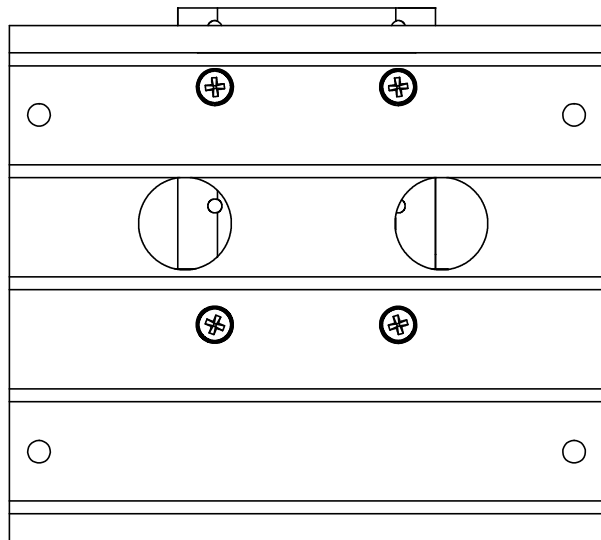
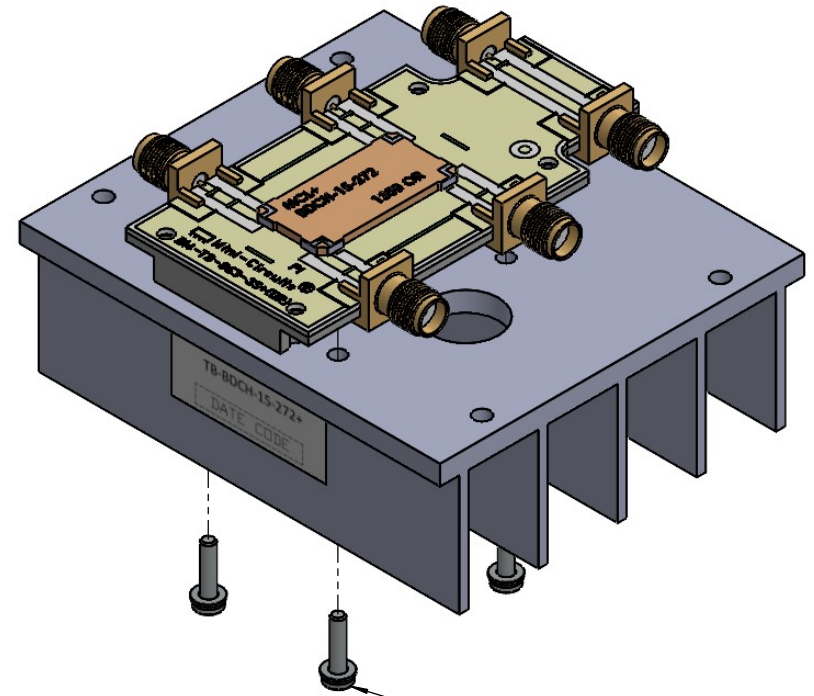
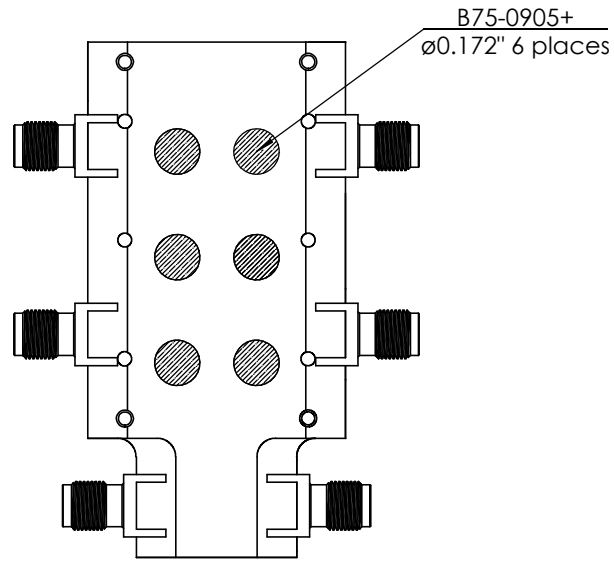

B16-10-53+

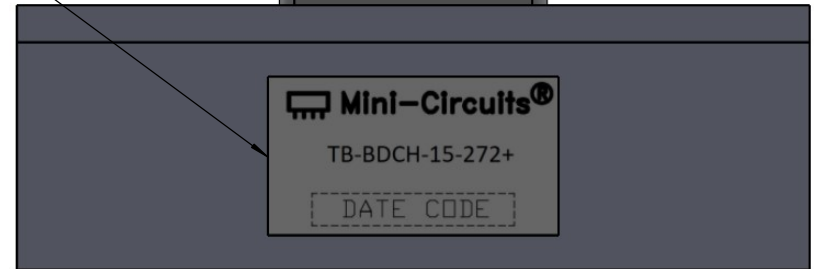

		ALL DIMENSIONS ARE IN INCHES EXCEPT OTHERWISE SPECIFIED			
<small>THIS DOCUMENT AND ITS CONTENTS ARE THE PROPERTY OF MINI-CIRCUITS ISRAEL LTD. EXCEPT FOR USE EXPRESSLY GRANTED, IN WRITING, TO ITS VENDORS, VEEDEE AND THE ISRAELI GOVERNMENT. MINI-CIRCUITS ISRAEL LTD RESERVES ALL PROPRIETARY DESIGN, USE, MANUFACTURING AND REPRODUCTION RIGHTS THERETO. THESE CONTENTS SHALL NOT BE USED, DUPLICATED OR DISCLOSED TO ANY OUTSIDE PARTY, IN WHOLE OR IN PART, WITHOUT WRITTEN PERMISSION OF MINI-CIRCUITS ISRAEL LTD.</small>		SIZE B	CODE IDENT 15542	DRAWING NO: IL-0433-20	REV: A0
FILE: TB-BDCH-15-272 +(A0)		SCALE: 2:1	SHEET: 4 OF 4		