

# Evaluation Board and Circuit

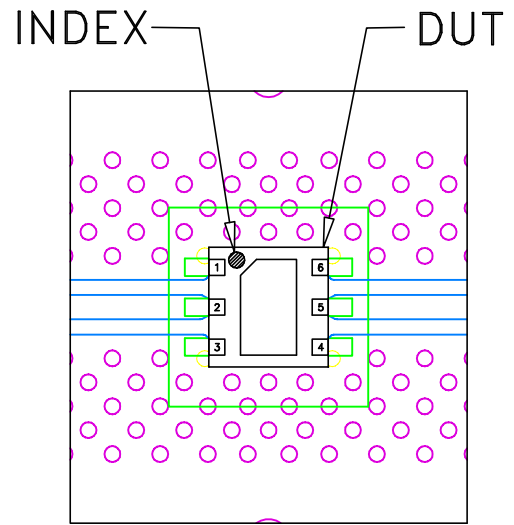

DETAIL "A"  
(SCALE 5:1)

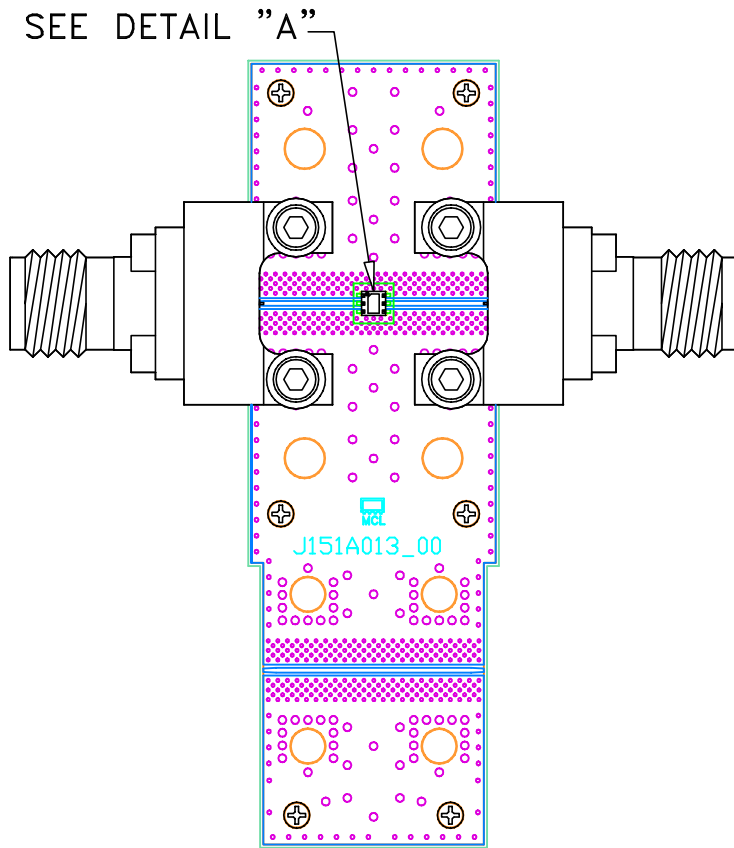
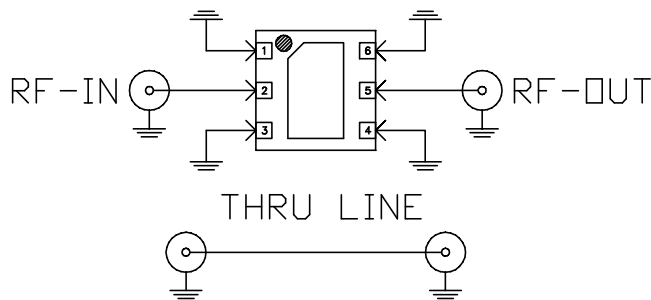

Schematic Diagram  
(Scale 5:1)

Function	Pad
RF-IN	2
RF-OUT	5
GND	1,3,4,6

## NOTES:

1. 1.85mm Female Connectors.
2. PCB Material: Roger RO4350B or equivalent,  
Dielectric constant=3.5, Thickness=0.0066 inch

 **Mini-Circuits®**