

# Coaxial Reflectionless Low Pass Filter

## ZXLF Series

50Ω DC to 11 GHz



### The Big Deal

- Patented design terminates Stopband signals
- Stopband up to 35 GHz
- High Stopband rejection, up to 50 dB

### Product Overview

Mini-Circuits' ZXLF Series reflectionless filters employ a novel filter topology which absorbs and terminates stop band signals internally rather than reflecting them back to the source. Reflectionless filters eliminate stopband reflections, allowing them to be paired with sensitive devices and used in applications that otherwise require circuits such as isolation amplifiers or attenuators. This is developed in a new broadband, stable connectorized package.

### Key Features

Feature	Advantages
Easy integration with sensitive reflective components, e.g. mixers, multipliers	Reflectionless filters absorb unwanted signals, preventing reflections back to the source. This reduces generation of additional unwanted signals without the need for extra components like attenuators, improving system dynamic range.
Cascadable	Reflectionless filters can be cascaded in multiple sections to provide sharper and higher attenuation, while also preventing any standing waves that could affect pass band signals.
Excellent stability over temperature	Minimal variation in electrical performance across temperature.
Operating temperature up to 105°C	Suitable for operation close to high power components.
Broadband connectorized package	The connectorized package works well even in high frequencies and easy to interface with other devices. This is well suited for test setups.

#### Notes

- A. Performance and quality attributes and conditions not expressly stated in this specification document are intended to be excluded and do not form a part of this specification document.  
B. Electrical specifications and performance data contained in this specification document are based on Mini-Circuit's applicable established test performance criteria and measurement instructions.  
C. The parts covered by this specification document are subject to Mini-Circuits standard limited warranty and terms and conditions (collectively, "Standard Terms"); Purchasers of this part are entitled to the rights and benefits contained therein. For a full statement of the Standard Terms and the exclusive rights and remedies thereunder, please visit Mini-Circuits' website at [www.minicircuits.com/MCLStore/terms.jsp](http://www.minicircuits.com/MCLStore/terms.jsp)



# Low Pass Filter

## ZXLF-K151+

50Ω DC to 150 MHz



Generic photo used for illustration purposes only

CASE STYLE: UK3042  
Connectors Model  
2.92mm-F ZXLF-K151+

### Features

- Match to 50Ω in the stop band, eliminates undesired reflections
- Cascadable
- Temperature stable, up to 105°C
- Protected by US Patent No. 8,392,495

### Electrical Specifications at 25°C

Parameter	F#	Frequency (MHz)	Min.	Typ.	Max.	Unit
Pass Band	DC-F1	DC- 150	-	1.3	2.0	dB
	F2	280	-	3.0	-	dB
	DC-F1	DC- 150	-	1.2	-	:1
Stop Band	F3-F4	460 - 2800	11	15	-	dB
	F4-F5	2800 - 16000	-	24	-	dB
	F3-F4	460 - 2800	-	1.2	-	:1
	F4-F5	2800 - 16000	-	1.8	-	:1

### Applications

- Military / Defense
- Aircraft communication

### Absolute Maximum Ratings<sup>3</sup>

Parameter	Ratings
Operating Temperature	-55°C to +105°C
Storage Temperature	-55°C to +105°C
RF Power Input, Passband (DC-F1) <sup>1</sup>	2W at 25°C
RF Power Input, Stopband (F2-F5) <sup>2</sup>	0.5W at 25°C

<sup>1</sup> Passband rating derates linearly to 1W at 105°C ambient

<sup>2</sup> Stopband rating derates linearly to 0.25W at 105°C ambient

<sup>3</sup> Permanent damage may occur if any of these limits are exceeded

### Functional Schematic

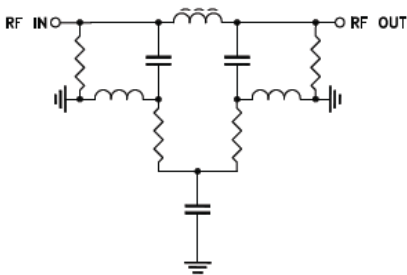

### Typical Frequency Response

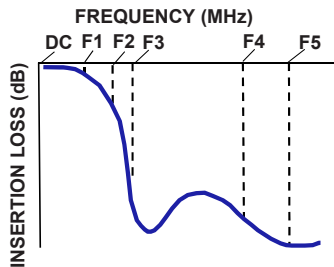

### Typical Performance Data at 25°C

Frequency (MHz)	Insertion Loss (dB)	VSWR (:1)
1	0.99	1.14
10	0.98	1.14
100	1.11	1.16
150	1.31	1.19
280	2.86	1.23
300	3.43	1.21
400	9.05	1.14
460	15.32	1.17
700	16.42	1.16
1000	14.97	1.09
2800	16.27	1.39
3000	13.85	1.53
5000	35.10	1.51
5200	34.61	1.55
8000	27.20	1.81
10000	32.13	2.53
12000	18.88	1.52
13000	19.65	2.08
15000	19.82	3.03
16000	19.91	3.25

#### +RoHS Compliant

The +Suffix identifies RoHS Compliance. See our web site for RoHS Compliance methodologies and qualifications

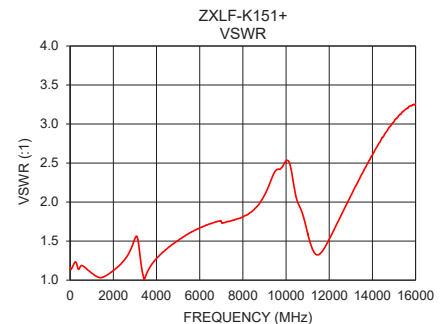
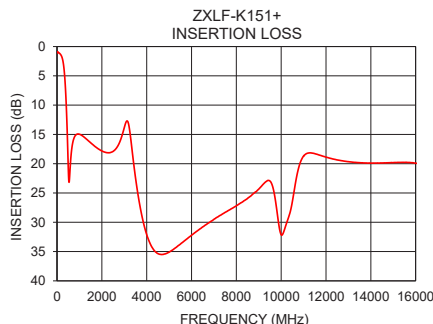

#### Notes

- Performance and quality attributes and conditions not expressly stated in this specification document are intended to be excluded and do not form a part of this specification document.
- Electrical specifications and performance data contained in this specification document are based on Mini-Circuits' applicable established test performance criteria and measurement instructions.
- The parts covered by this specification document are subject to Mini-Circuits standard limited warranty and terms and conditions (collectively, "Standard Terms"); Purchasers of this part are entitled to the rights and benefits contained therein. For a full statement of the Standard Terms and the exclusive rights and remedies thereunder, please visit Mini-Circuits' website at [www.minicircuits.com/MCLStore/terms.jsp](http://www.minicircuits.com/MCLStore/terms.jsp)



## Coaxial Connections

PORT - 1	2.92mm-Female
PORT - 2	2.92mm-Female

## Outline Drawing

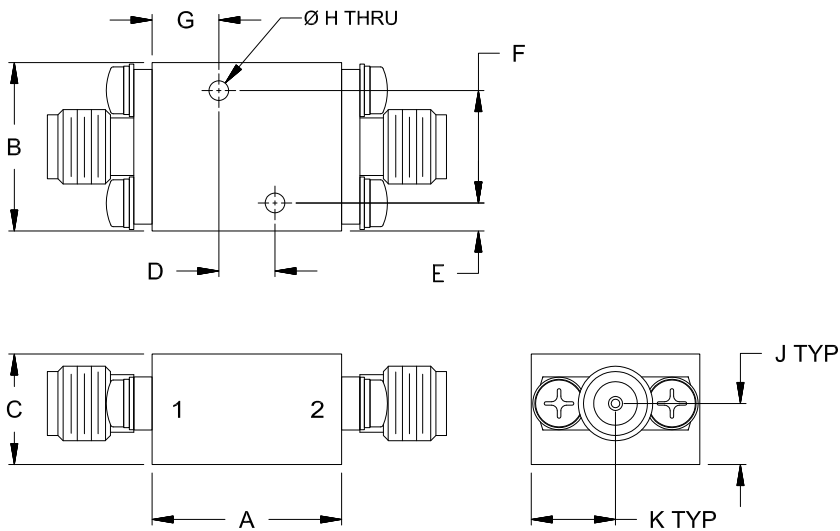

## Outline Dimensions (inch/mm)

A	B	C	D	E	F
.68	.60	.39	.200	.10	.400
17.1	15.2	10.0	5.08	2.5	10.16
G	H	J	K	Wt.	
.24	.070	.22	.30	grams	
6.0	1.78	5.5	7.6	24	

Note: Please refer to case style drawing for details

### Notes

- A. Performance and quality attributes and conditions not expressly stated in this specification document are intended to be excluded and do not form a part of this specification document.
- B. Electrical specifications and performance data contained in this specification document are based on Mini-Circuit's applicable established test performance criteria and measurement instructions.
- C. The parts covered by this specification document are subject to Mini-Circuits standard limited warranty and terms and conditions (collectively, "Standard Terms"); Purchasers of this part are entitled to the rights and benefits contained therein. For a full statement of the Standard Terms and the exclusive rights and remedies thereunder, please visit Mini-Circuits' website at [www.minicircuits.com/MCLStore/terms.jsp](http://www.minicircuits.com/MCLStore/terms.jsp)



# Coaxial Reflectionless Low Pass Filter

# ZXLF-K151+

## Typical Performance Data

FREQ.	Insertion Loss	Input Return Loss	Output Return Loss	FREQ.	Group Delay
(MHz)	(dB)	(dB)	(dB)	(MHz)	(ns)
1	0.99	23.58	23.72	1	0.51
5	0.98	23.72	23.69	2	0.53
10	0.98	23.65	23.69	3	0.56
15	0.99	23.64	23.69	4	0.59
25	1.00	23.60	23.64	5	0.62
50	0.96	23.73	23.80	6	0.64
100	1.11	22.39	22.50	7	0.66
150	1.31	21.09	21.13	8	0.68
280	2.86	19.89	19.91	9	0.70
300	3.43	20.41	20.40	10	0.73
400	9.05	23.74	23.64	11	0.77
460	15.32	22.25	22.22	12	0.79
700	16.42	22.61	22.85	13	0.80
800	15.28	24.07	24.36	14	0.80
1000	14.97	27.47	28.19	15	0.80
1200	15.44	32.10	33.62	16	0.80
1400	16.10	36.53	37.30	17	0.80
1500	16.43	34.95	34.38	18	0.80
2000	17.83	24.80	24.46	19	0.80
2500	17.90	18.96	19.24	20	0.81
2800	16.27	15.77	16.26	21	0.81
3000	13.85	13.54	14.20	22	0.81
3200	13.38	15.54	16.31	23	0.81
3500	22.38	31.70	30.84	24	0.81
3600	24.99	25.04	25.56	25	0.81
3800	29.16	20.42	21.29	26	0.81
4000	32.10	18.31	19.30	27	0.81
4200	34.01	16.91	18.02	28	0.81
4500	35.35	15.46	16.70	29	0.81
4800	35.42	14.42	15.74	30	0.80
5000	35.10	13.86	15.24	31	0.81
5200	34.61	13.36	14.78	32	0.81
5500	33.74	12.74	14.19	33	0.81
5800	32.83	12.29	13.70	34	0.82
6000	32.21	12.02	13.43	35	0.82
6200	31.63	11.80	13.14	36	0.82
6500	30.79	11.53	12.78	37	0.82
6800	30.03	11.29	12.39	38	0.82
7000	29.50	11.29	12.25	39	0.82
7500	28.31	11.18	11.71	40	0.81
7900	27.42	10.90	10.91	41	0.81
8000	27.20	10.82	10.74	42	0.82
8100	26.93	10.68	10.51	43	0.84
8700	25.31	9.79	9.05	44	0.85
9000	24.34	9.06	8.22	45	0.85
9300	23.13	8.19	7.38	46	0.84
10000	32.13	7.27	6.92	47	0.83
10500	26.45	9.37	9.76	48	0.82
11000	18.70	12.72	14.30	49	0.82
11500	18.29	17.09	18.55	50	0.82
12000	18.88	13.66	14.56	60	0.82
12500	19.36	10.87	12.10	70	0.82
13000	19.65	9.09	10.55	80	0.83
13500	19.83	7.88	9.46	90	0.83
14000	19.90	7.04	8.57	100	0.83
14500	19.88	6.41	7.80	110	0.84
15000	19.82	5.96	7.09	120	0.85
15500	19.78	5.65	6.44	130	0.86
15750	19.80	5.56	6.12	140	0.87
16000	19.91	5.52	5.85	150	0.88

## Typical Performance Curves

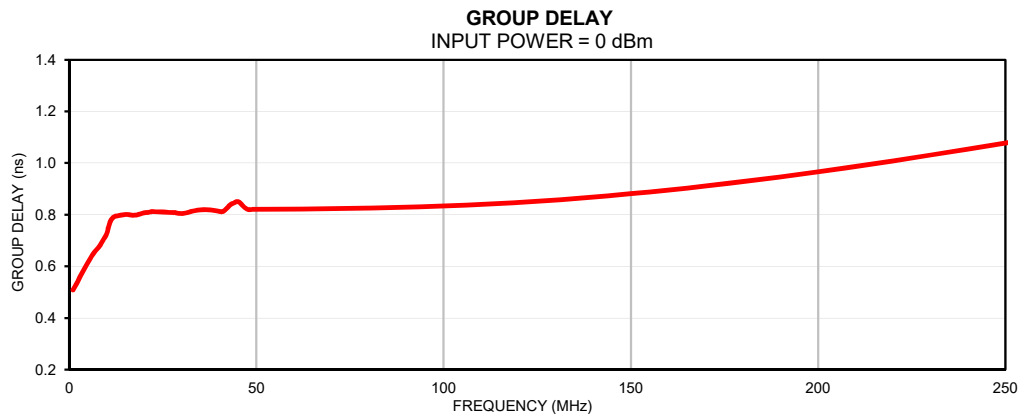
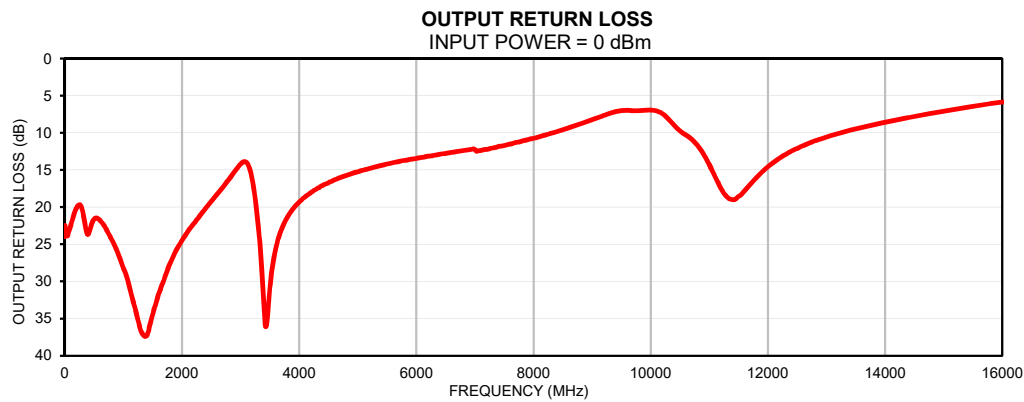
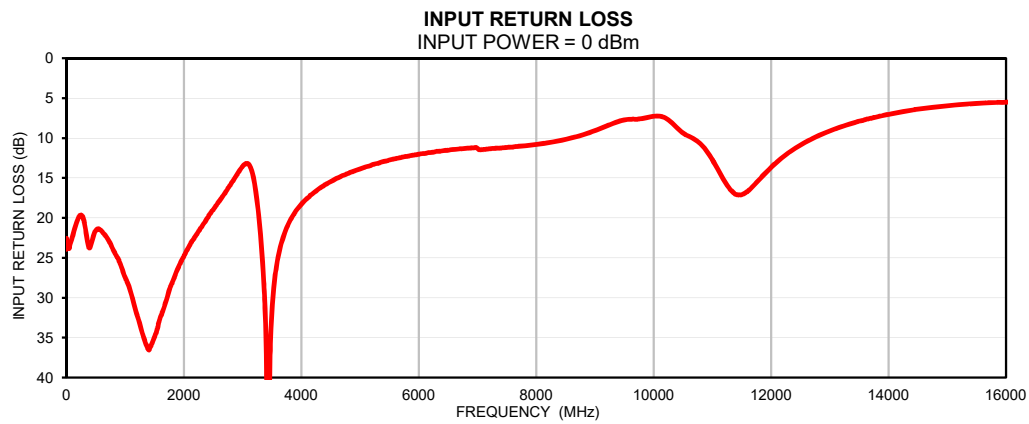
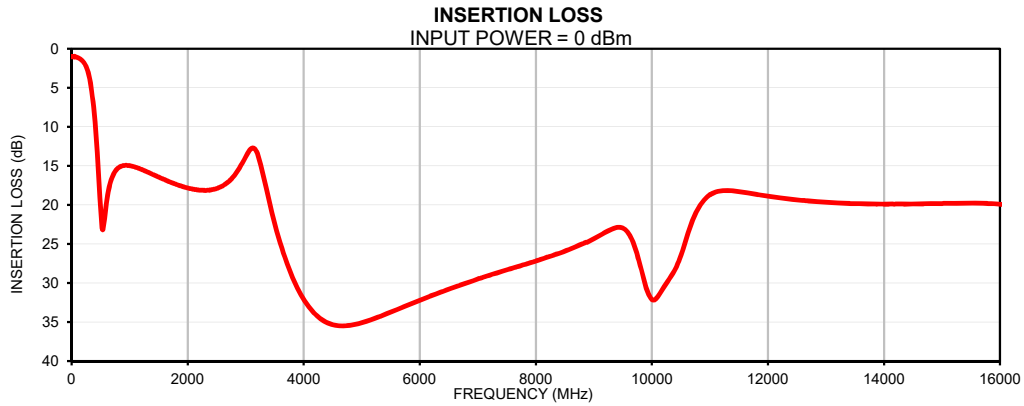

## Outline Dimensions

UK3042

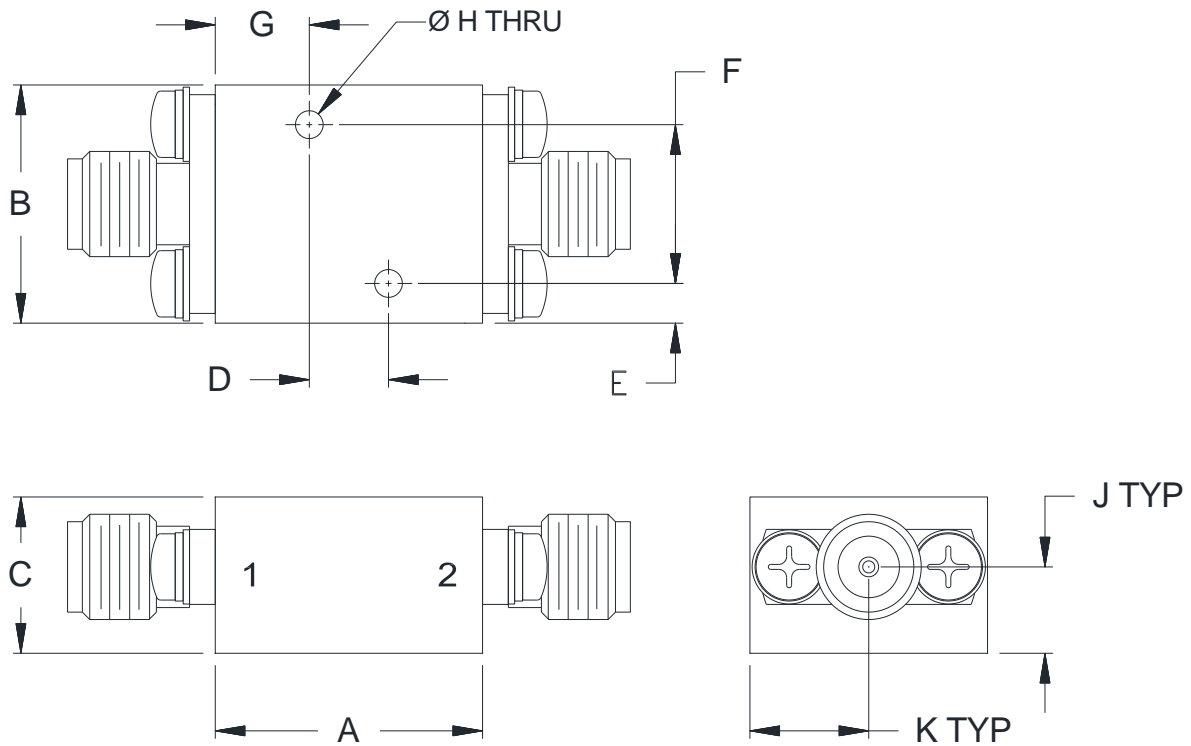

CASE#	A	B	C	D	E	F
UK3042	.68 (17.1)	.60 (15.2)	.39 (10.0)	.200 (5.08)	.10 (2.5)	.400 (10.16)

CASE#	G	H	J	K	WT.GRAMS
UK3042	.24 (6.0)	.070 (1.78)	.22 (5.5)	.30 (7.6)	24

Dimensions are in inches (mm). Tolerances: 2 Pl.  $\pm .050$ ; 3 Pl.  $\pm .015$

### Notes:

1. Case material: Brass alloy.
2. Case Finish:
  - a. Case & Cover of the units –Gold plating.
3. Refer to the individual model data sheet for the type of connectors available.



P.O. Box 350166, Brooklyn, New York 11235-0003 (718) 934-4500 Fax (718) 332-4661 For detailed performance specs & shopping online see Mini-Circuits web site



The Design Engineers Search Engine Provides ACTUAL Data Instantly From MINI-CIRCUITS At: [www.minicircuits.com](http://www.minicircuits.com)

RF/IF MICROWAVE COMPONENTS

All Mini-Circuits products are manufactured under exacting quality assurance and control standards, and are capable of meeting published specifications after being subjected to any or all of the following physical and environmental test.

<b>Specification</b>	<b>Test/Inspection Condition</b>	<b>Reference/Spec</b>
Operating Temperature	-55° to 105°C Ambient Environment	Individual Model Data Sheet
Storage Temperature	-55° to 105°C Ambient Environment	Individual Model Data Sheet