

Coaxial Reflectionless Low Pass Filter

ZXLF-Series

50Ω DC to 20 GHz

The Big Deal

- Patented design terminates stopband signal internally
- Stopband performance up to 40 GHz
- Small In-line package size of 0.80" x 0.56"



CASE STYLE: RA2937

Product Overview

Mini-Circuits' ZXLF Series of reflectionless filters employ a novel filter topology which absorbs and terminates stop band signals internally rather than reflecting them back to the source. Reflectionless filters minimize the stopband reflections, thereby allowing them to be paired with sensitive devices and be used in applications that otherwise require circuits such as isolation amplifiers or attenuators. This is developed in a new broadband connectorized package that delivers stable performance over temperature.

Key Features

Feature	Advantages
Easy integration with sensitive reflective components, e.g. mixers, multipliers	Reflectionless filters absorb unwanted signals, preventing reflections back to the source. This reduces generation of additional unwanted signals without the need for extra components like attenuators, improving system dynamic range.
Cascadable	Reflectionless filters can be cascaded in multiple sections to provide sharper and higher attenuation, while also preventing any standing waves that could affect pass band signals.
Excellent stability over temperature	Ensures minimal variation in electrical performance across temperature.
Wide Operating temperature from -40 to +85°C	Suitable for use in wide temperature range applications.
Broadband connectorized package	The connectorized package works well even in high frequencies and easy to interface with other devices. This is well suited for test setups.



Coaxial Reflectionless Low Pass Filter

50Ω DC to 13 GHz

Features

- Match to 50Ω in the stop band, eliminates undesired reflections
- Cascadable
- Temperature stable, up to 85°C
- Protected by US Patent No. 8,392,495

Applications

- Harmonics Rejection
- Satellite
- Radar
- Military & Space

Functional Schematic

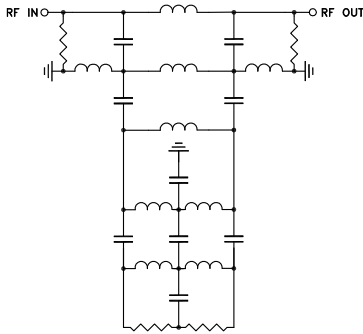

ZLXF-K133+



Generic photo used for illustration purposes only

CASE STYLE: RA2937
Connectors Model
2.92mm-F to 2.92mm-M ZLXF-K133+

+RoHS Compliant
The +Suffix identifies RoHS Compliance. See our web site for RoHS Compliance methodologies and qualifications

Electrical Specifications at 25°C

Parameter	F#	Frequency (MHz)	Min.	Typ.	Max.	Unit	
Pass Band	Insertion Loss	DC-F1	DC-13000		1.7	2.8	dB
	Freq. Cut-off	F2	15000		3.0		dB
	VSWR	DC-F1	DC-13000		1.45		:1
Stop Band	Rejection	F3-F4	20000-30000	18.0	23.0		dB
		F4-F5	30000-35000		20.0		dB
	VSWR	F3-F4	20000-30000		3.0		:1
		F4-F5	30000-35000		5.8		:1

Absolute Maximum Ratings³

Operating Temperature	-40°C to +85°C
Storage Temperature	-55°C to +100°C
RF Power Input, Passband (DC-F1) ¹	2W at 25°C
RF Power Input, Stopband (F2-F5) ²	50mW at 25°C

¹ Passband rating derates linearly to 1W at 85°C ambient

² Stopband rating derates linearly to 25mW at 85°C ambient

³ Permanent damage may occur if any of these limits are exceeded

ESD rating

Human Body Model (HBM): Class 1A (250 to <500V) in accordance with ANSI/ESD 5.1 - 2001

Typical Performance Data at 25°C

Frequency (GHz)	Insertion Loss (dB)	VSWR (:1)
10	0.31	1.02
100	0.34	1.02
1000	0.53	1.12
2000	0.70	1.23
4000	0.90	1.32
6000	1.06	1.28
10000	1.40	1.14
13000	2.10	1.52
15000	2.89	1.61
18000	8.20	1.53
20000	24.18	1.28
23000	30.73	4.23
26000	22.62	1.64
30000	26.32	4.53
32000	24.13	6.34
35000	18.83	5.73

Specification Definition

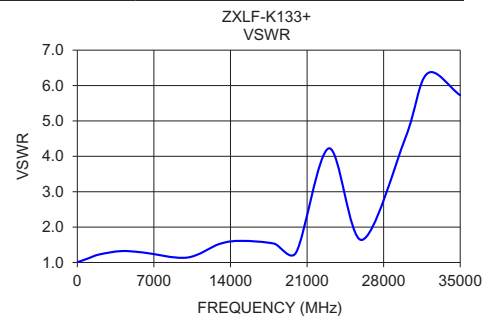
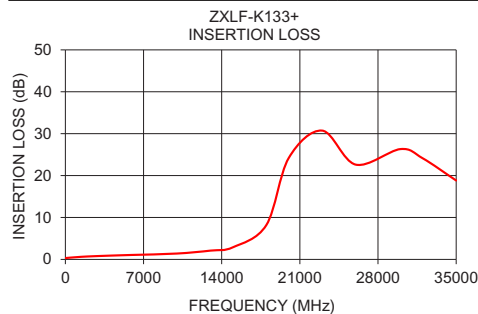
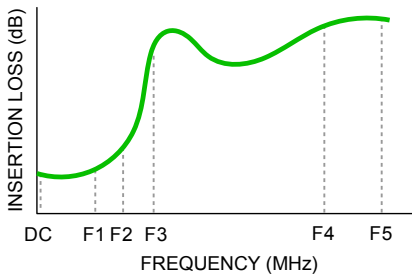

Coaxial Connections

PORT - IN	2.92mm-Fem
PORT - OUT	2.92mm-Male

Outline Drawing

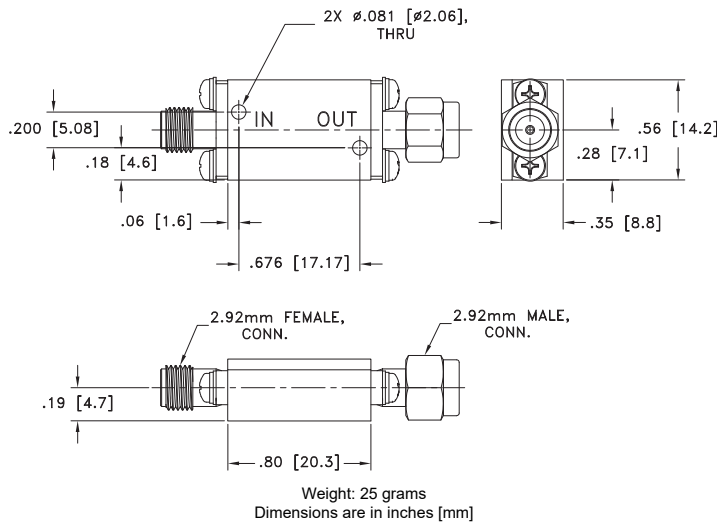

Additional Notes

- Performance and quality attributes and conditions not expressly stated in this specification document are intended to be excluded and do not form a part of this specification document.
- Electrical specifications and performance data contained in this specification document are based on Mini-Circuit's applicable established test performance criteria and measurement instructions.
- The parts covered by this specification document are subject to Mini-Circuits standard limited warranty and terms and conditions (collectively, "Standard Terms"); Purchasers of this part are entitled to the rights and benefits contained therein. For a full statement of the Standard Terms and the exclusive rights and remedies thereunder, please visit Mini-Circuits' website at www.minicircuits.com/MCLStore/terms.jsp

Typical Performance Data

FREQUENCY (MHz)	INSERTION LOSS (dB)			INPUT RETURN LOSS (dB)			OUTPUT RETURN LOSS (dB)		
	@ -40°C	@ +25°C	@ +85°C	@ -40°C	@ +25°C	@ +85°C	@ -40°C	@ +25°C	@ +85°C
10	0.30	0.33	0.32	36.60	37.82	39.18	38.20	39.60	37.96
100	0.39	0.40	0.34	36.73	37.97	41.86	41.74	43.88	43.02
500	0.47	0.49	0.44	31.63	31.56	33.13	35.40	35.08	33.49
1000	0.57	0.59	0.53	24.92	24.80	23.79	24.61	24.29	24.87
1500	0.66	0.68	0.62	20.48	20.22	19.84	21.84	21.78	22.16
2000	0.75	0.77	0.69	19.29	19.19	18.56	19.56	19.45	19.75
2500	0.80	0.83	0.76	18.58	18.42	18.33	18.83	18.70	18.49
3000	0.83	0.87	0.81	18.27	18.11	17.88	18.22	18.06	17.82
3500	0.88	0.92	0.86	17.93	17.77	17.51	17.65	17.51	17.49
4000	0.93	0.96	0.90	17.44	17.27	16.99	17.33	17.29	17.30
4500	0.97	1.01	0.95	17.24	17.13	16.98	17.43	17.44	17.27
5000	1.01	1.05	1.00	17.26	17.16	16.98	17.48	17.50	17.28
5500	1.04	1.09	1.04	17.39	17.30	17.03	17.40	17.43	17.32
6000	1.07	1.13	1.08	17.67	17.57	17.13	17.47	17.55	17.45
6500	1.11	1.17	1.13	17.72	17.73	17.38	17.74	17.89	17.72
7000	1.15	1.20	1.17	18.41	18.55	18.15	18.27	18.50	18.16
7500	1.18	1.24	1.21	19.29	19.67	19.41	18.92	19.26	18.99
8000	1.21	1.28	1.25	20.48	21.08	20.61	19.48	19.92	19.63
8500	1.23	1.30	1.28	21.40	22.21	21.90	19.79	20.31	19.90
9000	1.29	1.37	1.35	22.53	23.54	23.14	19.85	20.34	19.96
9500	1.30	1.38	1.37	23.00	23.99	23.74	20.60	21.02	20.79
10000	1.36	1.45	1.44	23.08	23.90	23.81	23.38	23.85	23.65
10500	1.41	1.50	1.50	22.79	23.13	23.09	30.56	31.93	32.05
11000	1.47	1.57	1.57	21.11	20.99	20.78	26.92	27.31	27.70
11500	1.54	1.65	1.66	18.54	18.24	18.00	20.36	20.40	20.40
12000	1.67	1.80	1.82	16.13	15.91	15.63	17.13	17.13	17.06
12500	1.84	1.97	2.01	14.23	14.18	13.99	15.38	15.45	15.33
13000	2.03	2.17	2.22	13.06	13.18	12.99	14.19	14.35	14.16
13500	2.18	2.33	2.39	12.71	13.04	12.89	12.96	13.21	13.02
14000	2.34	2.51	2.58	12.78	13.28	13.17	11.99	12.29	12.14
14500	2.52	2.70	2.80	13.10	13.75	13.76	11.53	11.91	11.83
15000	2.70	2.92	3.03	13.46	14.14	14.32	11.77	12.25	12.29
15500	2.93	3.19	3.32	13.63	14.16	14.45	12.78	13.38	13.61
16000	3.29	3.60	3.77	13.36	13.68	14.08	14.00	14.70	15.36
16500	3.79	4.19	4.41	12.83	12.92	13.35	14.60	15.20	16.31
17000	4.57	5.08	5.37	12.05	12.03	12.34	14.65	14.97	16.07
17500	5.72	6.38	6.78	11.45	11.41	11.64	14.55	14.55	15.26
18000	7.42	8.23	8.76	11.30	11.36	11.62	13.97	13.82	14.12
18500	9.77	10.73	11.41	11.83	12.13	12.57	12.68	12.68	12.91
19000	12.80	13.96	14.81	13.98	14.68	15.50	12.31	12.68	13.04
19500	16.71	18.17	19.27	20.09	20.84	21.35	14.69	15.23	15.58
20000	22.31	24.17	25.57	20.43	17.93	16.53	17.77	16.17	15.38
20500	30.48	32.61	34.06	12.29	11.53	11.04	11.88	11.00	10.54
21000	40.39	40.84	40.96	8.61	8.33	8.13	8.25	7.96	7.75
21500	41.26	40.86	40.58	6.73	6.66	6.57	6.30	6.21	6.10
22000	37.94	37.55	37.09	5.81	5.85	5.83	4.96	4.96	4.89
22500	34.35	33.91	33.46	5.47	5.62	5.64	4.14	4.20	4.17
23000	31.17	30.80	30.42	5.55	5.76	5.84	3.82	3.96	3.97
23500	28.51	28.24	27.95	5.86	6.13	6.27	4.08	4.29	4.35
24000	26.44	26.29	26.08	6.42	6.72	6.93	4.88	5.18	5.28
24500	24.66	24.62	24.52	7.26	7.59	7.85	6.22	6.57	6.72
25000	23.13	23.23	23.24	8.51	8.86	9.17	7.94	8.31	8.45
25500	22.29	22.57	22.70	9.97	10.33	10.65	9.99	10.29	10.35
26000	22.14	22.58	22.84	11.44	11.68	11.93	12.43	12.48	12.28
26500	22.62	23.24	23.64	12.38	12.27	12.23	14.82	14.55	14.07
27000	23.69	24.51	25.02	11.79	11.31	11.11	16.31	16.01	15.67
27500	25.34	26.25	26.95	9.76	9.42	9.10	15.81	15.57	15.63
28000	26.52	27.55	28.39	8.60	8.25	7.83	12.69	12.42	12.52
28500	27.42	28.34	28.88	7.09	6.81	6.59	9.29	9.11	9.14
29000	27.30	27.93	28.19	5.83	5.70	5.53	6.91	6.83	6.81
29500	26.71	27.12	27.24	4.96	4.91	4.80	5.49	5.47	5.40
30000	26.08	26.39	26.46	4.36	4.36	4.27	4.45	4.45	4.36
30500	25.51	25.79	25.84	3.96	3.97	3.90	3.61	3.60	3.51
31000	25.01	25.25	25.29	3.71	3.72	3.65	2.99	2.99	2.90
31500	24.53	24.76	24.80	3.55	3.57	3.53	2.39	2.40	2.33
32000	24.01	24.24	24.26	3.45	3.49	3.46	2.04	2.07	2.03
32500	23.30	23.52	23.52	3.36	3.42	3.42	1.93	2.00	1.97
33000	22.74	22.80	22.81	3.30	3.34	3.34	2.04	2.11	2.09
33500	22.31	22.43	22.33	3.06	3.13	3.13	2.15	2.26	2.25
34000	21.02	21.06	21.04	2.99	3.03	3.02	2.37	2.49	2.49
34500	19.80	19.89	19.83	2.96	2.99	2.98	2.70	2.86	2.88
35000	18.71	18.80	18.71	2.93	2.96	2.95	3.20	3.39	3.44

Typical Performance Curves

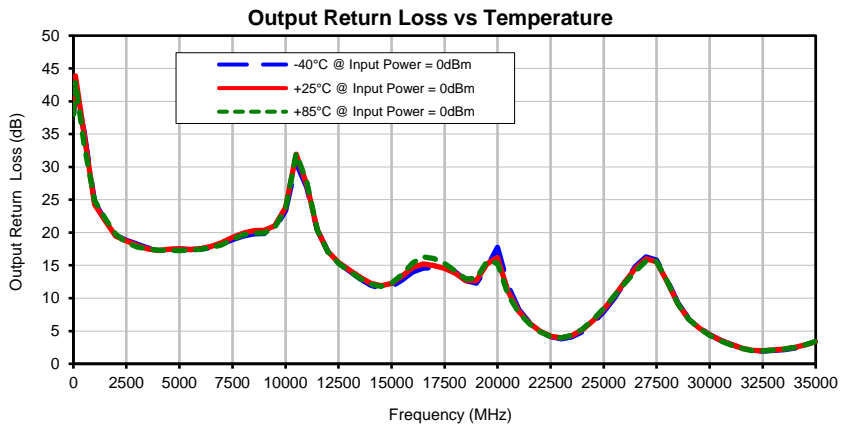
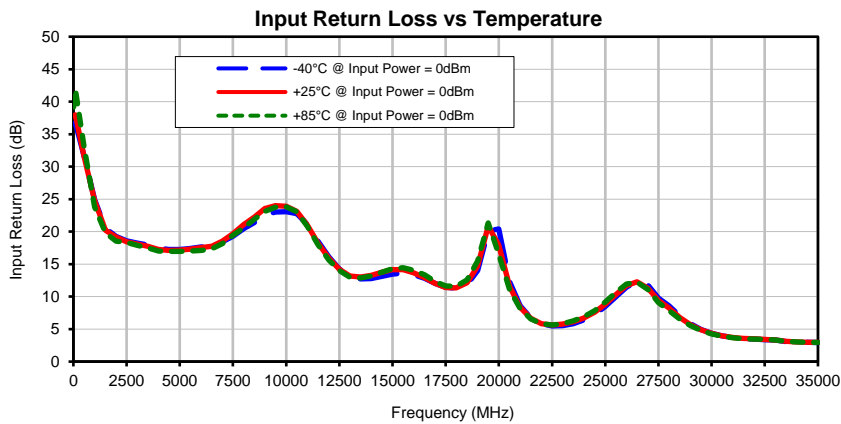
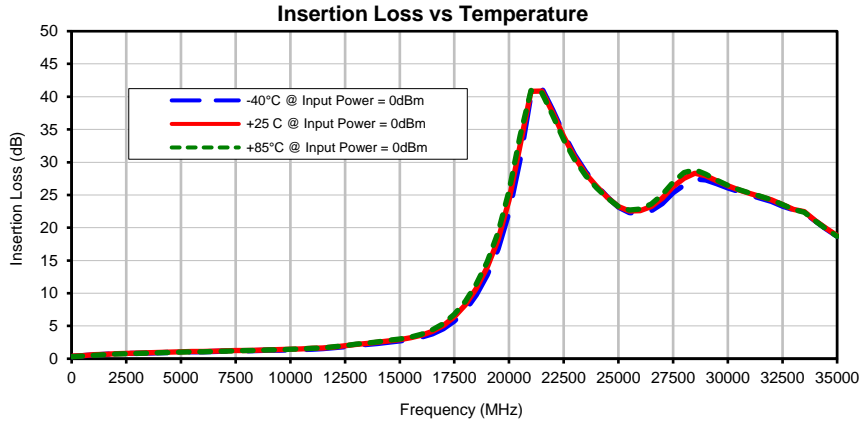

Outline Dimensions

RA2937

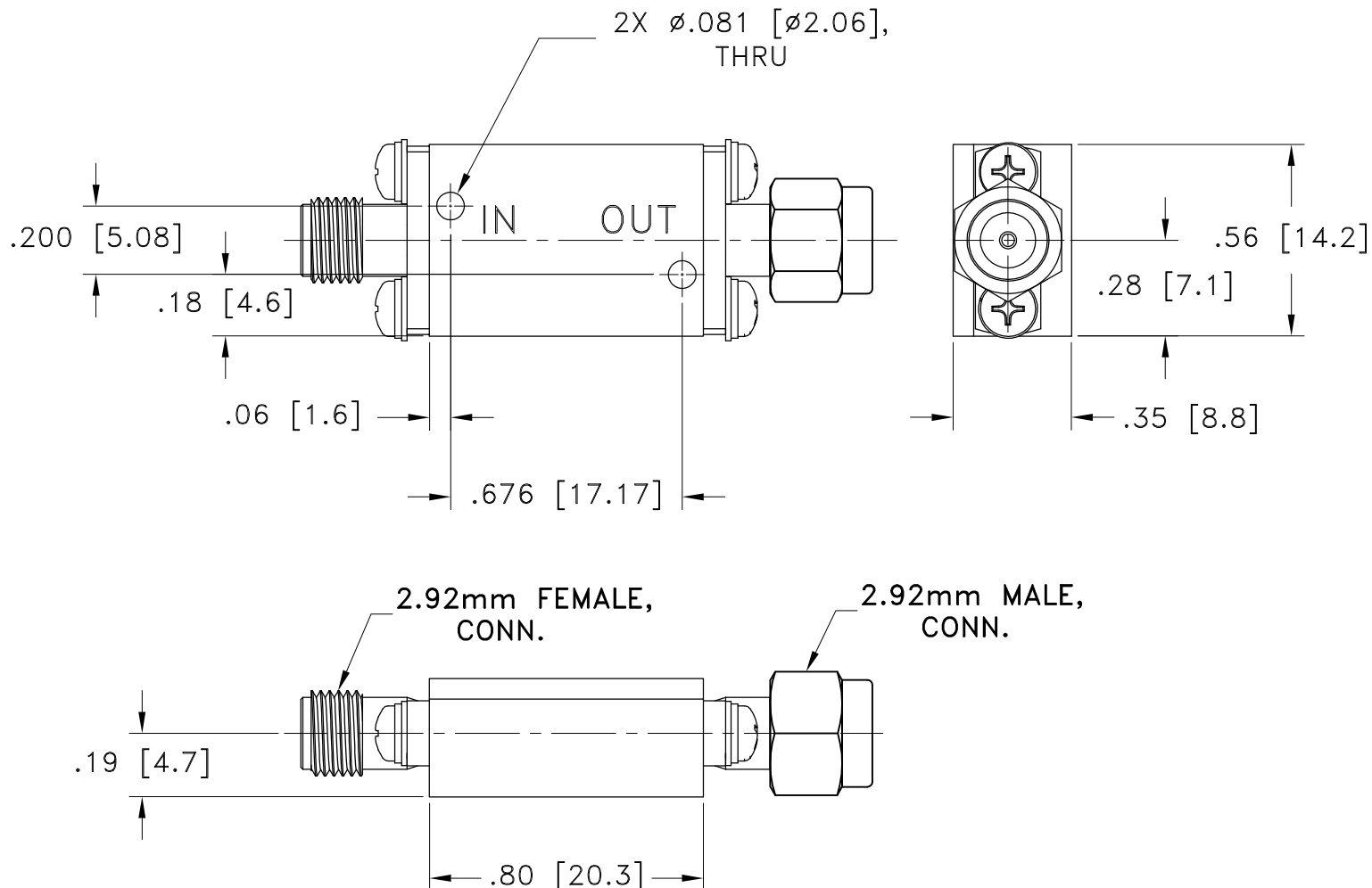

Weight: 25 grams

Dimensions are in inches (mm). Tolerances: 2 Pl. \pm .015; 3 Pl. \pm .005

Notes:

1. Case material: Brass.
2. Case Finish: Gold plate.



All Mini-Circuits products are manufactured under exacting quality assurance and control standards, and are capable of meeting published specifications after being subjected to any or all of the following physical and environmental test.

Specification	Test/Inspection Condition	Reference/Spec
Operating Temperature	-40° to 85° C Ambient Environment	Individual Model Data Sheet
Storage Temperature	-55° to 100° C Ambient Environment	Individual Model Data Sheet
Thermal Shock	-55° to 100°C, 100 cycles	MIL-STD-202, Method 107, Condition A-3, except +100°C