

USB/RS232 Variable Attenuator ZVVA-3000

50Ω 0.1 dB step, 20-3000 MHz

The Big Deal

- Very fine attenuation resolution (0.1 dB)
- Glitchless transitions (0 dB glitch)
- **USB and RS232** control



Software Package

Case Style: QF2252

Applications

- Signal level calibration
- Gain control feedback circuits
- Automated test equipment (ATE)
- Control systems

Included Accessories

Model No.	Description	Qty.
MUSB-CBL-3+	2.6 ft. USB cable	1

RoHS Compliant

See our web site for RoHS Compliance methodologies and qualifications

Product Overview

Mini Circuits' ZVVA-3000 is a 50 Ω RF variable attenuator which combines the performance benefits of a voltage variable design with the convenience and ease-of-use of a software controlled step attenuator. This model operates from 20 MHz to 3 GHz with fine attenuation steps of 0.1 dB and monotonic attenuation transitions, meaning no uncontrolled 'glitches' when transitioning from one attenuation to the next.

The attenuator is housed in a compact and rugged package with SMA female connectors for the bi-directional input and output RF ports, a standard 9 pin D-Sub and a USB type Mini-B for power and control.

The attenuator can be controlled via USB or RS232 (via D-Sub connector). Full software support is provided and can be downloaded from our website any time at <http://www.minicircuits.com/softwaredownload/patt.html>. The software package includes our user-friendly GUI application for Windows® and a full API with programming instructions for Windows® and Linux® environments, both 32-bit and 64-bit systems.

Key Features

Feature	Advantages
Novel hybrid design	Combination of voltage variable PIN diodes with digital interface provides very fine attenuation steps (0.1 dB) and glitchless transitions between states
High speed attenuation sequences	Integrated memory / microcontroller allows custom attenuation sequences to be pre-programmed and executed at high speed, with as little as 900 μs per step
USB & RS232 control	Full software support provided for quick & easy control via USB & RS232, with DC power also supplied via either interface
High linearity	Typical IP3 of +52 dBm reduces signal distortion to minimize the impact of the device on sensitive transmitter / receiver measurements

Trademarks: Windows is a registered trademark of Microsoft Corporation in the United States and other countries. Linux is a registered trademark of Linus Torvalds. Pentium is a registered trademark of Intel Corporation. Neither Mini-Circuits nor the Mini-Circuits ZVVA-series attenuators are affiliated with or endorsed by the owners of the above referenced trademarks

Mini-Circuits and the Mini-Circuits logo are registered trademarks of Scientific Components Corporation.



www.minicircuits.com P.O. Box 350166, Brooklyn, NY 11235-0003 (718) 934-4500 sales@minicircuits.com

Rev. C
M176882
EDR-10410/3
ZVVA-3000
RAV
200204
Page 1 of 9

Electrical Specifications ¹

Parameter	Frequency range	Conditions	Min.	Typ.	Max.	Units
Frequency range	-	-	20		3000	MHz
Attenuation resolution	20 - 3000 MHz	All attenuation settings	-	0.1	-	dB
Nominal Attenuation range ²	20 - 3000 MHz	-	0		40	dB
Max Attenuation ²	20 - 500 MHz	@ 40 dB attenuation setting	30	40	-	dB
	500 - 1500 MHz		23	32	-	
	1500 - 3000 MHz		17	24	-	
Insertion Loss	20 - 500 MHz	@ 0 dB attenuation setting	-	2.8	4.0	dB
	500 - 2500 MHz		-	3.5	5.5	
	2500 - 3000 MHz		-	4.0	6.0	
Attenuation Flatness ^{2,3}	20 - 500 MHz	@ 0.1 - 5 dB	-	±0.03	±0.10	dB
		@ 5.1 - 15 dB	-	±0.07	±0.15	
		@ 15.1 - 20 dB	-	±0.10	±0.20	
	500 - 1500 MHz	@ 20.1 - 25 dB	-	±0.12	±0.25	
		@ 0.1 - 5 dB	-	±0.05	±0.20	
		@ 5.1 - 15 dB	-	±0.30	±0.55	
	1500 - 3000 MHz	@ 15.1 - 20 dB	-	±0.40	±0.70	
		@ 20.1 - 25 dB	-	±0.60	±1.65	
		@ 0.1 - 5 dB	-	±0.15	±0.45	
@ 5.1 - 15 dB		-	±0.60	±1.0		
@ 15.1 - 20 dB		-	±0.90	±1.70		
@ 20.1 - 25 dB		-	±1.60	-		
Attenuation Accuracy	20 - 3000 MHz	@ 0.1 - 15 dB	-	±0.70	-	dB
VSWR ²	20 - 500 MHz	@ 0 - 25 dB	-	1.35	-	:1
	500 - 1500 MHz		-	1.30	-	
	1500 - 3000 MHz		-	1.20	-	
Max Input Power	20 - 3000 MHz	20 - 3000 MHz	-	-	+23	dBm
Input IP3	20 - 3000 MHz	@ 0 dB setting (P _{IN} =+5 dBm per tone, Δf=1MHz)	-	+52	-	dBm
Min Dwell Time ⁴	20 - 3000 MHz	High speed mode	-	900	-	μs
Attenuation Transition Time ⁵	20 - 3000 MHz	-	-	30	-	μs
Supply Voltage (via USB or D-Sub)	-	-	4.75	5	5.25	V
DC current draw (via USB or D-Sub)	-	@ 0 dB	-	110	150	mA
	-	@ 40 dB	-	65	100	
RS232 logic levels	Meets RS232 standard at all voltages with RS232 communications set to 9600 bps; 8 bit word; no parity; stop bit = '1'.					

¹ Attenuator RF ports are interchangeable, however the specifications are guaranteed for the RF in and RF out as noted on the label. There might be minor changes in the performance when input and output ports are reversed.

² The Attenuator allows setting attenuations up to 40 dB however performance is guaranteed only up to 25 dB setting.

³ Attenuation flatness is defined as the variation over frequency of the attenuation level.

⁴ Minimum Dwell Time is the time the ZVVA will take to respond to a command to change attenuation states without communication delays. In "PC control" add communication delays (on the order of ms for USB) to get actual response time.

⁵ Attenuation Transition Time is specified as the time between starting to change the attenuation state and settling on the requested attenuation state.

⁶ Power on sequence for RS232 control: First power on 5V supply voltage before any control signal is given.

Absolute Maximum Ratings

Operating Temperature	0°C to 50°C
Storage Temperature	-20°C to 85°C
Voltage input at D-Sub Pin#3	-30V to +30V
Voltage input at D-Sub Pin#2	0V to +4V
Voltage input at D-Sub Pin#1	-1V to +6V
V _{USB} Max.	6V
Max DC at RF ports	25V
Total RF power for RF In & RF Out	+26 dBm

Permanent damage may occur if any of these limits are exceeded.

Operating in the range between operating power limits and absolute maximum ratings for extended periods of time may result in reduced life and reliability.



Connections

RF IN	(SMA female)
RF OUT	(SMA female)
USB	(USB type Mini-B female)
RS232*	(9 Pin D-Sub female)

*9 Pin D-Sub Pin Connections

PIN Number	Function
1	+5 V _{DC} ⁸
2	RS232 Transmit
3	RS232 Receive
4	Not Connected
5	GND
6,7,8,9	Not connected

⁷ Pin#1 can be used as supply voltage pin instead of USB connection. When USB power is connected, Pin#1 may be connected to GND or supply voltage or remain disconnected.

ZVVA response to communication interrupt

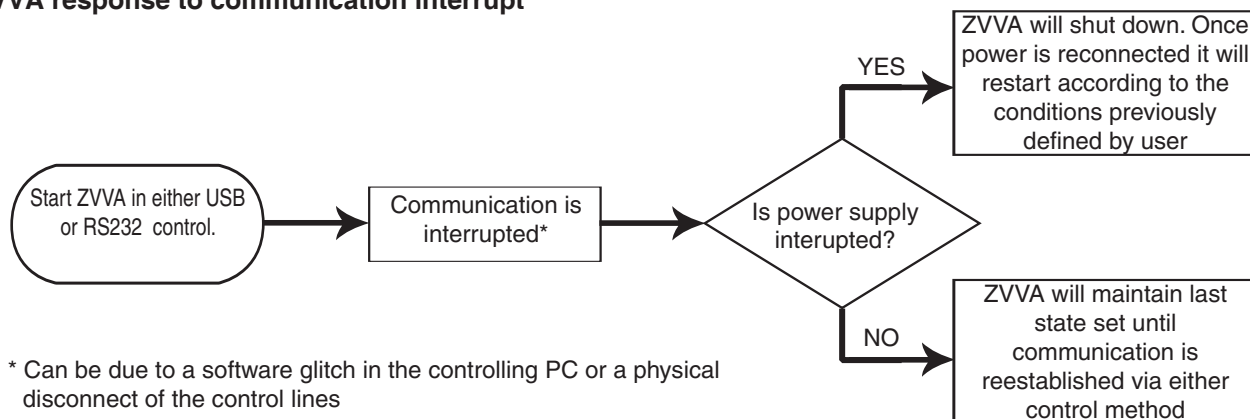

Simplified Diagram

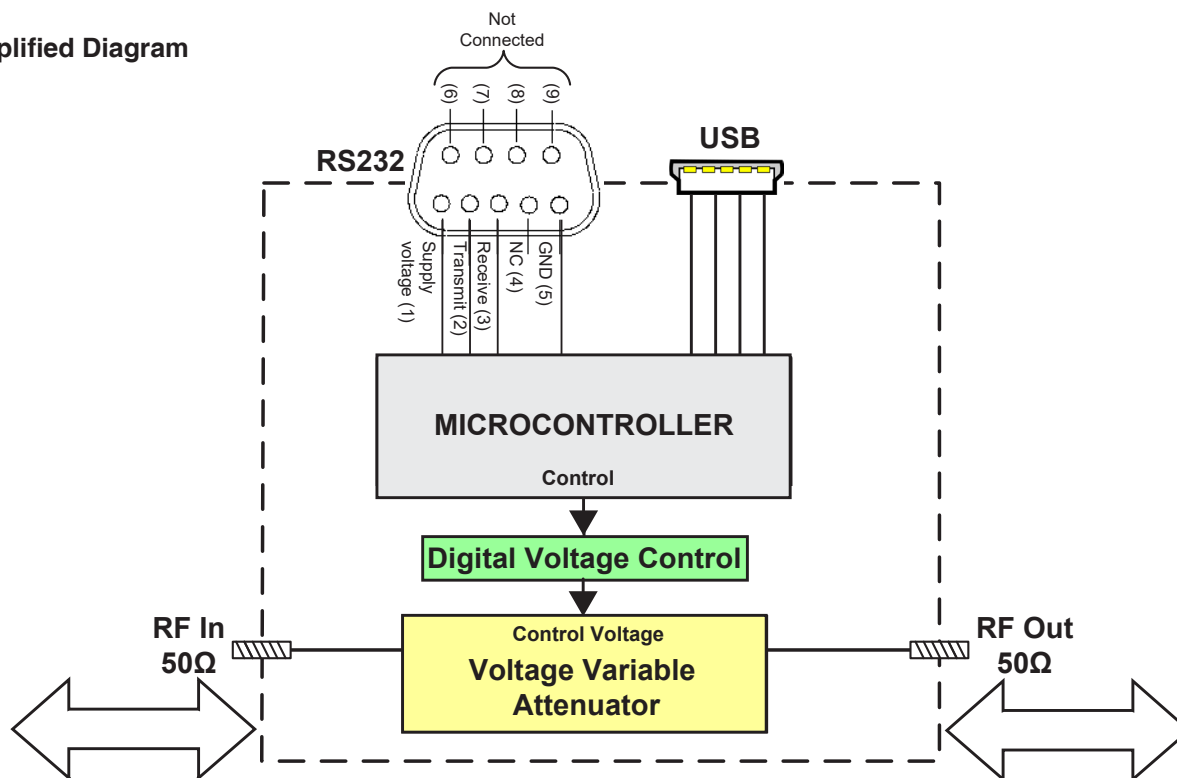

Simultaneous, bidirectional RF signal transmission with symmetrical performance

Insertion Loss vs. Frequency

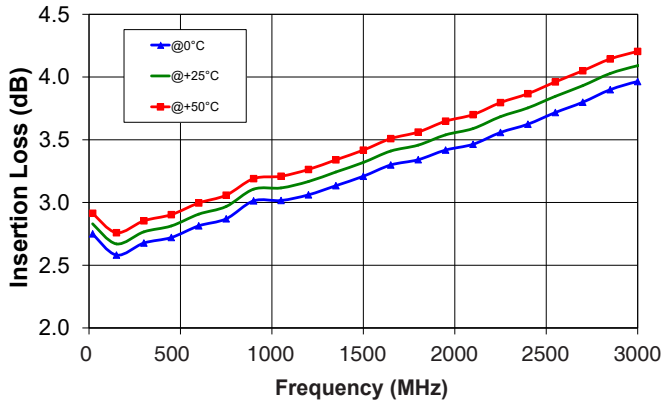

Attenuation relative to I.L. @ 0°C vs. Frequency at selected Atten. settings

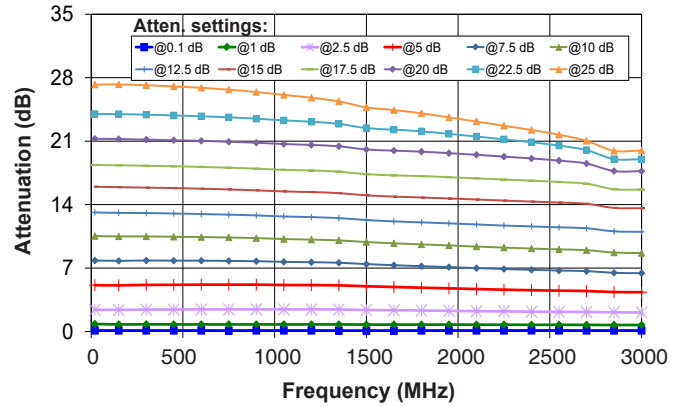

Attenuation @ 40 dB setting vs. Frequency

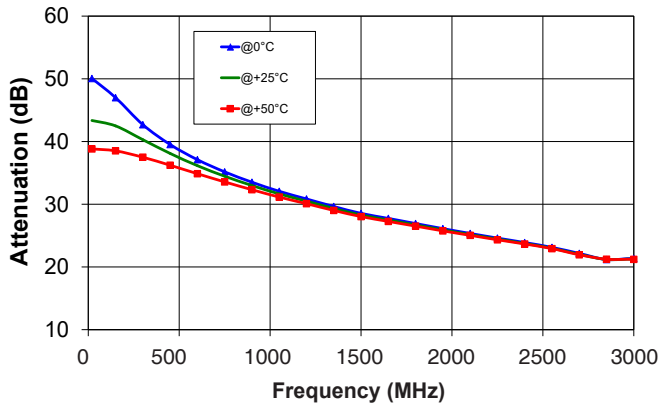

Attenuation relative to I.L. @ +25°C vs. Frequency at selected Atten. settings

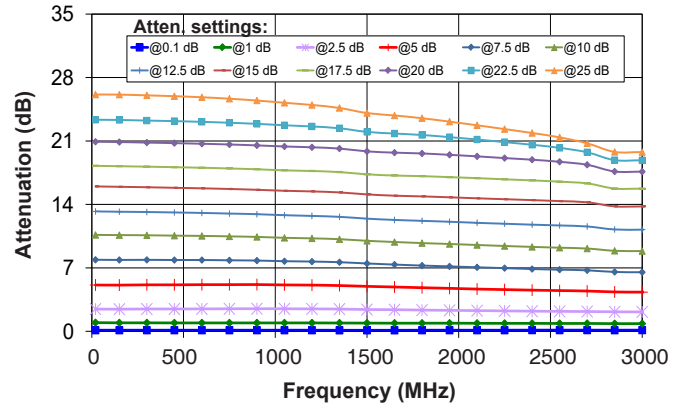

IP3 @ 0dB Attenuation

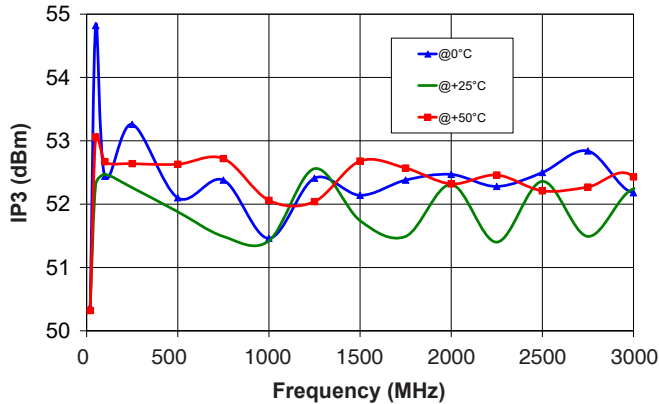

Attenuation relative to I.L. @ +50°C vs. Frequency at selected Atten. settings

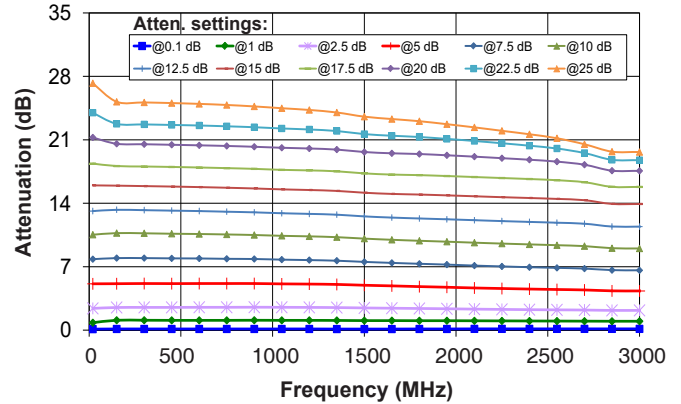

Typical Performance Curves

Attenuation Accuracy @ 0°C vs. Frequency at selected Atten. settings

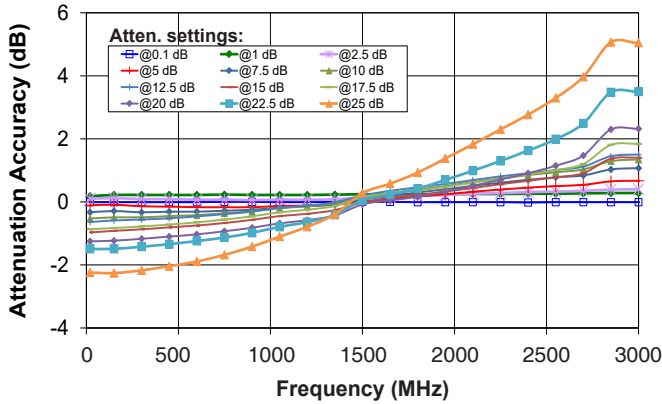

Attenuation Accuracy @ 0°C vs. Atten. settings @ Selected Frequencies

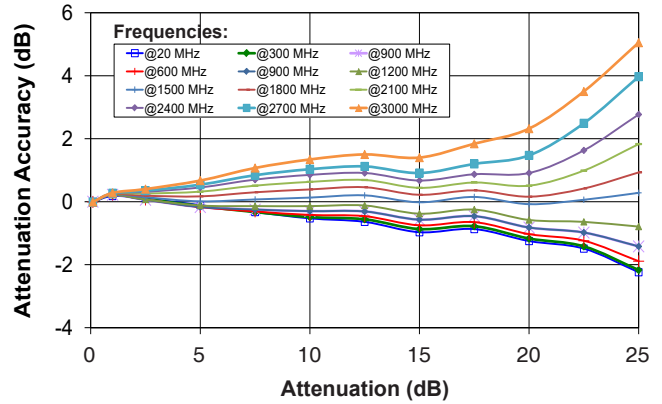

Attenuation Accuracy @ +25°C vs. Frequency at selected Atten. settings

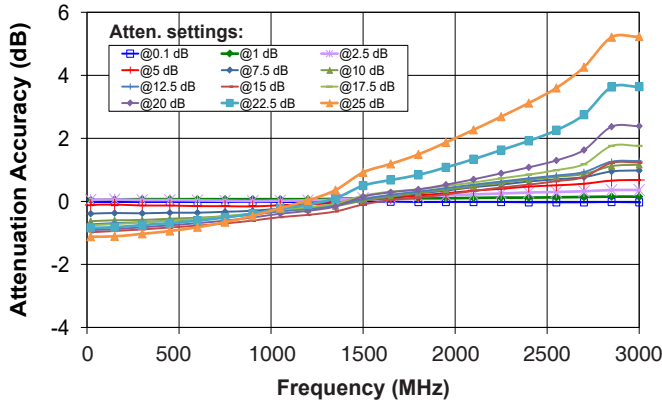

Attenuation Accuracy @ +25°C vs. Atten. settings @ Selected Frequencies

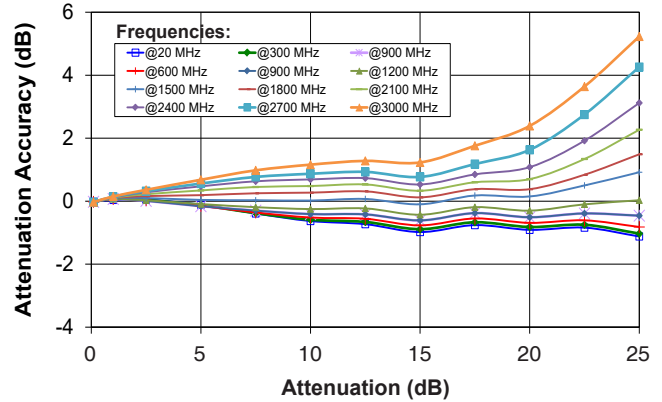

Attenuation Accuracy @ +50°C vs. Frequency at selected Atten. settings

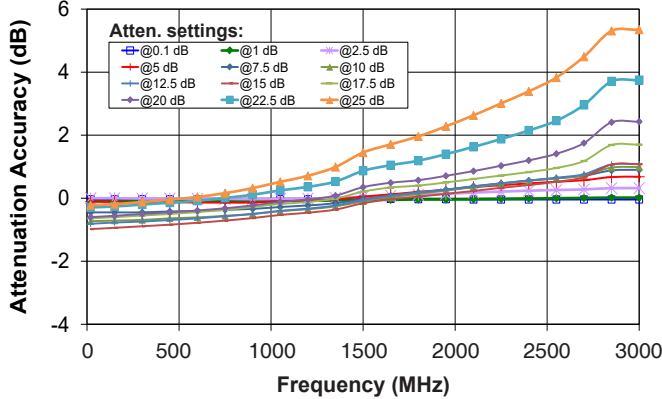

Attenuation Accuracy @ +50°C vs. Atten. settings @ Selected Frequencies

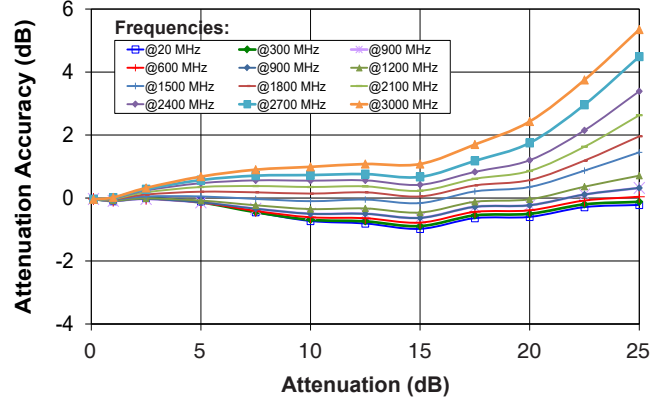

Typical Performance Curves

**VSWR In vs. Frequency
@ Selected Atten. settings**

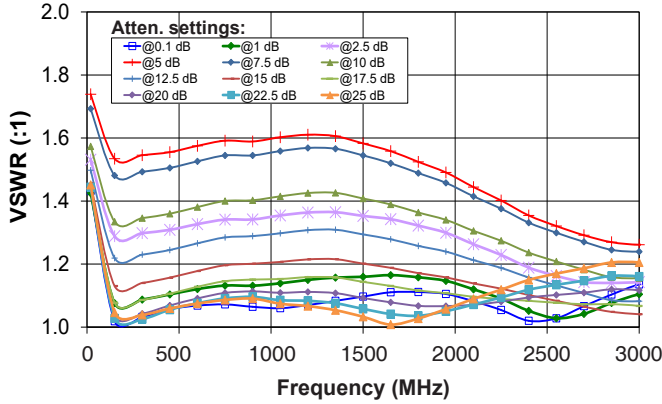

**VSWR In vs. Atten. settings
@ Selected Frequencies**

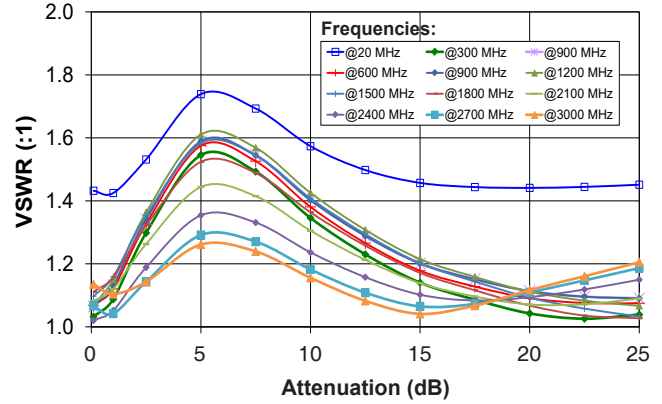

**VSWR Out vs. Frequency
@ Selected Atten. settings**

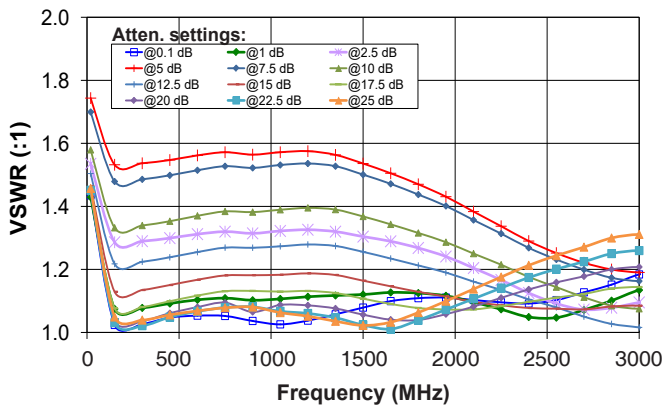

**VSWR Out vs. Atten. settings
@ Selected Frequencies**

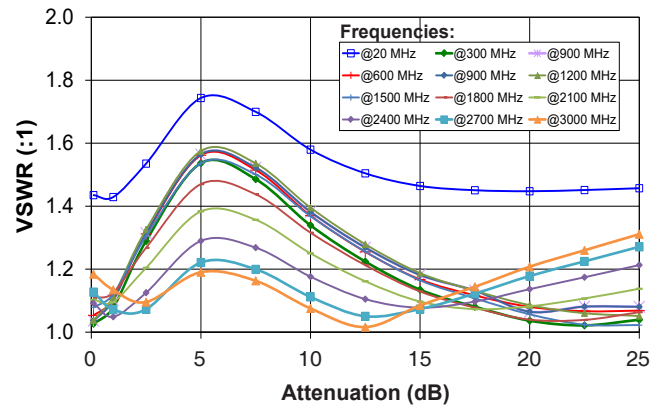

**Attenuation transition
(Input: 20 MHz, 0 dBm)**

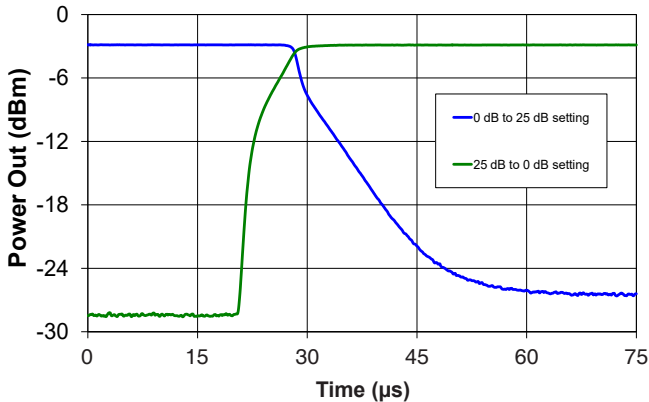

**Attenuation transition
(Input: 20 MHz, 0 dBm)**

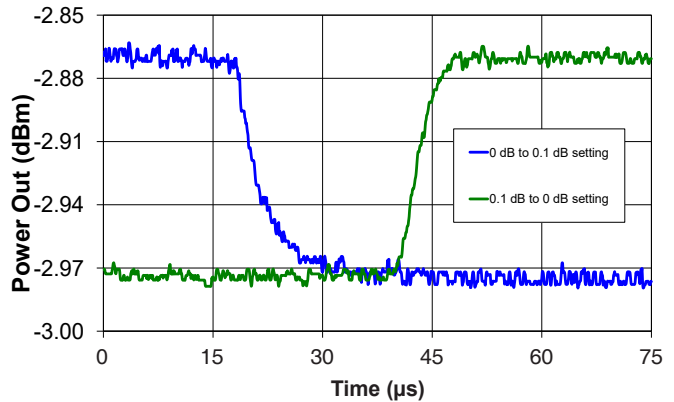

Outline Drawing (QF2252)

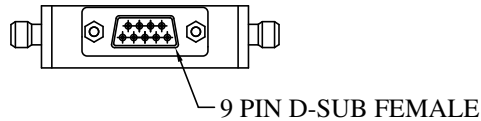

TOP VIEW

BRACKET OPTION

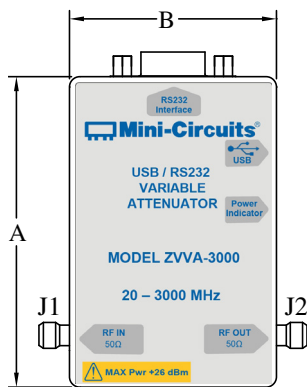

BOTTOM VIEW

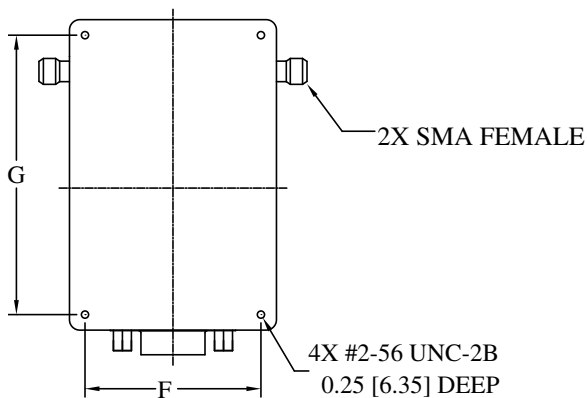
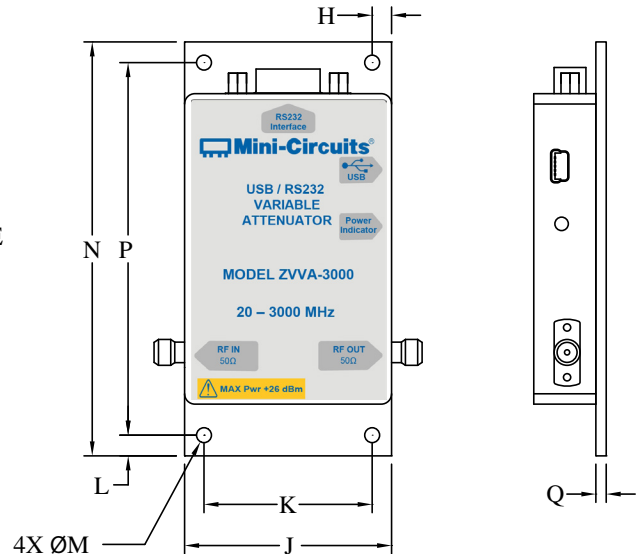
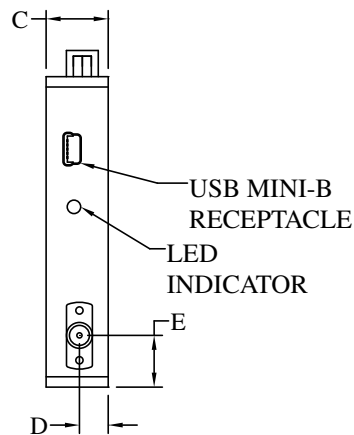

Instruction for mounting bracket:

1. Tool required: Phillips head screwdriver
2. Mount the bracket over threaded holes on the bottom side with the fasteners provided with the bracket.

Outline Dimensions (inch mm)

A	B	C	D	E	F	G	H	J	K	L	M	N	P	Q	WT. GRAMS
3.00	2.00	0.60	0.28	0.50	1.700	2.700	0.188	2.00	1.625	0.200	0.144	4.00	3.600	0.100	130
76.2	50.8	15.2	7.1	12.7	43.18	68.58	4.76	50.8	41.28	5.08	3.66	101.6	91.44	2.54	

Software & Documentation Download:

- Mini-Circuits' full software and support package including user guide, Windows GUI, DLL files, programming manual and examples can be downloaded free of charge from <http://www.minicircuits.com/softwaredownload/patt.html>
- Please contact testsolutions@minicircuits.com for support

Minimum System Requirements

Parameter	Requirements	
Interface	USB HID or RS232	
System requirements	GUI:	Windows 32 & 64 bit systems from Windows 98 up to Windows 10
	USB API (ActiveX & .Net)	Windows 32 & 64 bit systems with ActiveX or .Net support from Windows 98 up to Windows 10
	USB direct programming support	Linux, Windows systems from Windows 98 up to Windows 10
	RS232	Any computer with a serial port and RS232 support
Hardware	Pentium® II or higher, RAM 256 MB	

Graphical User Interface (GUI) for Windows

Key Features:

- Manual attenuation setting
- Sweep and Hop attenuation sequences directed from the PC, or entire sequence loaded into ZVVA.
- Attenuator address configuration and Firmware upgrade
- Attenuation at power up may be set to selected attenuation level or last attenuation state recorded.
- USB or RS232 control of ZVVA

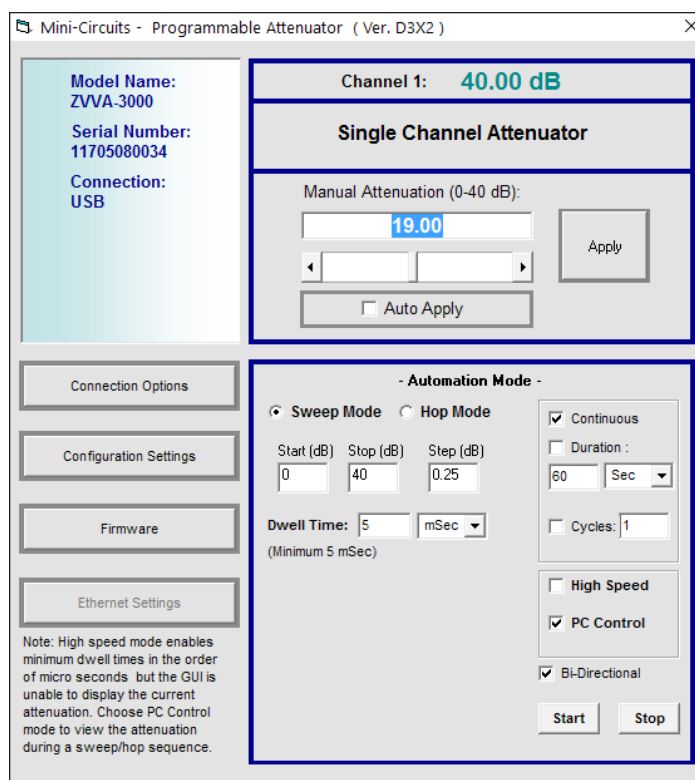

Application Programming Interface (API)

Windows Support:

- API DLL files exposing the full switch functionality See programming manual at https://www.minicircuits.com/softwaredownload/Prog_Manual-6-Programmable_Attenuator.pdf for details
 - ActiveX COM DLL file for creation of 32-bit programs
 - .Net library DLL file for creation of 32 / 64-bit programs
- Supported by most common programming environments (refer to application note [AN-49-001](#) for summary of tested environments)

Linux Support:

- Full switch control in a Linux environment is achieved by way of USB interrupt commands. See programming manual at https://www.minicircuits.com/softwaredownload/Prog_Manual-6-Programmable_Attenuator.pdf for details

Ordering Information

Model	Description
ZVVA-3000	USB Variable Attenuator

Included Accessories	Part No.	Description
	MUSB-CBL-3+	2.6 ft (0.8 m) USB Cable: USB type A(Male) to USB type Mini-B(Male)

Optional Accessories	Description
USB-AC/DC-5	AC/DC 5V _{DC} Power Adapter with US, EU, IL, UK, AUS, and China power plugs ^{8,9}
MUSB-CBL-3+ (spare)	2.6 ft (0.8 m) USB Cable: USB type A(Male) to USB type Mini-B(Male)
MUSB-CBL-7+	6.6 ft (2.0 m) USB Cable: USB type A(Male) to USB type Mini-B(Male)
D-SUB9-MF-6+	6 ft RS232 Cable: 9 pin D-sub(Male) to 9 pin D-sub(Female)
BKT-3901+	Bracket kit including 3.75" x 2.00" bracket, mounting screws and washers

⁸ Not used in USB control. USB-AC/DC-5 can be used to provide the 5V_{DC} power when control is via RS232; units can also accept DC supply voltage at Pin#1 of the D-sub connector.

⁹ Power plugs for other countries are also available, if you need a power plug for a country not listed please contact testsolutions@minicircuits.com

Additional Notes

- A. Performance and quality attributes and conditions not expressly stated in this specification document are intended to be excluded and do not form a part of this specification document.
- B. Electrical specifications and performance data contained in this specification document are based on Mini-Circuit's applicable established test performance criteria and measurement instructions.
- C. The parts covered by this specification document are subject to Mini-Circuits standard limited warranty and terms and conditions (collectively, "Standard Terms"); Purchasers of this part are entitled to the rights and benefits contained therein. For a full statement of the Standard Terms and the exclusive rights and remedies thereunder, please visit Mini-Circuits' website at www.minicircuits.com/MCLStore/terms.jsp

Programmable Attenuator

ZVVA-3000

Typical Performance Data @ 0°C

FREQUENCY (MHz)	Attenuation relative to Insertion Loss (dB)											
	0.1 dB	1 dB	2.5 dB	5 dB	7.5 dB	10 dB	12.5 dB	15 dB	17.5 dB	20 dB	22.5 dB	25 dB
20	0.11	0.82	2.40	5.11	7.83	10.53	13.14	15.97	18.37	21.26	23.99	27.24
50	0.11	0.79	2.38	5.09	7.82	10.52	13.14	15.97	18.39	21.28	24.04	27.32
100	0.11	0.79	2.39	5.11	7.82	10.52	13.12	15.94	18.36	21.25	24.01	27.29
200	0.11	0.79	2.39	5.11	7.81	10.49	13.08	15.90	18.31	21.21	23.96	27.23
300	0.11	0.79	2.41	5.14	7.83	10.49	13.07	15.87	18.28	21.17	23.92	27.17
400	0.11	0.78	2.42	5.16	7.83	10.48	13.04	15.84	18.24	21.13	23.87	27.09
500	0.11	0.78	2.43	5.17	7.83	10.45	13.01	15.80	18.20	21.08	23.81	27.00
600	0.11	0.78	2.43	5.17	7.81	10.42	12.96	15.75	18.15	21.03	23.74	26.89
700	0.11	0.78	2.44	5.18	7.80	10.39	12.92	15.70	18.09	20.96	23.67	26.75
800	0.11	0.78	2.44	5.18	7.78	10.35	12.87	15.64	18.03	20.90	23.59	26.60
900	0.11	0.78	2.44	5.17	7.75	10.30	12.81	15.57	17.96	20.82	23.48	26.42
1000	0.11	0.78	2.43	5.14	7.70	10.23	12.73	15.49	17.87	20.72	23.36	26.21
1100	0.11	0.78	2.43	5.13	7.66	10.18	12.67	15.42	17.81	20.65	23.24	26.00
1200	0.11	0.78	2.43	5.12	7.64	10.14	12.62	15.38	17.76	20.58	23.14	25.79
1300	0.10	0.78	2.42	5.10	7.60	10.08	12.55	15.30	17.68	20.49	23.00	25.53
1400	0.10	0.77	2.40	5.06	7.54	10.01	12.47	15.21	17.58	20.36	22.80	25.20
1500	0.10	0.76	2.37	4.99	7.43	9.87	12.30	15.02	17.35	20.08	22.44	24.72
1600	0.10	0.76	2.35	4.93	7.34	9.77	12.19	14.91	17.25	19.98	22.32	24.52
1700	0.11	0.76	2.33	4.88	7.27	9.68	12.12	14.85	17.20	19.92	22.22	24.33
1800	0.11	0.76	2.31	4.83	7.20	9.61	12.04	14.78	17.14	19.84	22.08	24.07
1900	0.11	0.76	2.28	4.78	7.13	9.53	11.97	14.71	17.06	19.73	21.90	23.78
2000	0.11	0.75	2.26	4.73	7.06	9.45	11.89	14.63	16.98	19.62	21.71	23.48
2100	0.11	0.75	2.24	4.68	6.99	9.37	11.81	14.56	16.89	19.49	21.51	23.17
2200	0.11	0.75	2.22	4.63	6.92	9.30	11.73	14.48	16.81	19.36	21.31	22.86
2300	0.11	0.75	2.20	4.59	6.86	9.22	11.66	14.41	16.72	19.23	21.10	22.55
2400	0.12	0.74	2.19	4.55	6.80	9.15	11.59	14.33	16.63	19.09	20.88	22.23
2500	0.11	0.74	2.17	4.51	6.74	9.09	11.52	14.26	16.54	18.93	20.64	21.89
2600	0.11	0.74	2.16	4.48	6.70	9.03	11.45	14.18	16.44	18.76	20.37	21.52
2700	0.11	0.73	2.15	4.46	6.66	8.97	11.39	14.09	16.30	18.53	20.01	21.03
2800	0.11	0.73	2.13	4.40	6.55	8.82	11.18	13.81	15.91	17.97	19.30	20.20
2900	0.11	0.72	2.10	4.32	6.42	8.66	10.98	13.56	15.62	17.64	18.97	19.91
3000	0.11	0.72	2.10	4.33	6.43	8.66	11.00	13.60	15.66	17.68	19.00	19.95

Notes

- A. Performance and quality attributes and conditions not expressly stated in this specification document are intended to be excluded and do not form a part of this specification document.
- B. Electrical specifications and performance data contained in this specification document are based on Mini-Circuits' applicable established test performance criteria and measurement instructions.
- C. The parts covered by this specification document are subject to Mini-Circuits standard limited warranty and terms and conditions (collectively, "Standard Terms"). Purchasers of this part are entitled to the rights and benefits contained therein. For a full statement of the Standard Terms and the exclusive rights and remedies thereunder, please visit Mini-Circuits' website at www.minicircuits.com/MCLStore/terms.jsp



Programmable Attenuator

ZVVA-3000

Typical Performance Data @ 0°C

FREQUENCY (MHz)	Attenuation accuracy relative to nominal attenuation setting (dB)											
	0.1 dB	1 dB	2.5 dB	5 dB	7.5 dB	10 dB	12.5 dB	15 dB	17.5 dB	20 dB	22.5 dB	25 dB
20	-0.01	0.18	0.10	-0.11	-0.33	-0.53	-0.64	-0.97	-0.87	-1.25	-1.49	-2.24
50	-0.01	0.21	0.12	-0.09	-0.32	-0.52	-0.64	-0.97	-0.89	-1.28	-1.54	-2.32
100	-0.01	0.21	0.11	-0.11	-0.32	-0.52	-0.62	-0.94	-0.86	-1.25	-1.51	-2.29
200	-0.01	0.22	0.11	-0.11	-0.31	-0.49	-0.58	-0.90	-0.81	-1.21	-1.46	-2.23
300	-0.01	0.22	0.09	-0.14	-0.33	-0.49	-0.56	-0.87	-0.78	-1.17	-1.42	-2.17
400	-0.01	0.22	0.08	-0.16	-0.33	-0.48	-0.54	-0.84	-0.74	-1.13	-1.37	-2.08
500	0.00	0.22	0.07	-0.17	-0.32	-0.45	-0.51	-0.80	-0.70	-1.08	-1.31	-2.00
600	-0.01	0.22	0.07	-0.17	-0.31	-0.42	-0.46	-0.75	-0.65	-1.03	-1.24	-1.89
700	0.00	0.22	0.06	-0.18	-0.30	-0.39	-0.42	-0.70	-0.59	-0.96	-1.17	-1.75
800	-0.01	0.22	0.06	-0.18	-0.28	-0.35	-0.37	-0.64	-0.53	-0.90	-1.08	-1.60
900	0.00	0.22	0.06	-0.17	-0.25	-0.30	-0.31	-0.57	-0.46	-0.82	-0.98	-1.42
1000	-0.01	0.22	0.07	-0.14	-0.20	-0.23	-0.23	-0.49	-0.37	-0.72	-0.86	-1.21
1100	-0.01	0.22	0.07	-0.13	-0.16	-0.18	-0.17	-0.42	-0.31	-0.65	-0.74	-1.00
1200	-0.01	0.22	0.07	-0.12	-0.14	-0.14	-0.12	-0.38	-0.25	-0.58	-0.64	-0.79
1300	0.00	0.22	0.08	-0.10	-0.10	-0.08	-0.05	-0.30	-0.18	-0.49	-0.50	-0.53
1400	0.00	0.23	0.10	-0.06	-0.04	-0.01	0.03	-0.21	-0.08	-0.36	-0.30	-0.20
1500	0.00	0.24	0.14	0.01	0.07	0.13	0.20	-0.02	0.15	-0.08	0.06	0.28
1600	0.00	0.24	0.16	0.07	0.16	0.23	0.31	0.09	0.25	0.02	0.18	0.48
1700	-0.01	0.24	0.17	0.12	0.23	0.32	0.39	0.15	0.30	0.08	0.28	0.67
1800	-0.01	0.24	0.19	0.17	0.30	0.39	0.46	0.22	0.36	0.16	0.42	0.93
1900	-0.01	0.24	0.22	0.22	0.37	0.47	0.53	0.29	0.44	0.27	0.60	1.22
2000	-0.01	0.25	0.24	0.27	0.44	0.55	0.61	0.37	0.52	0.39	0.79	1.52
2100	-0.01	0.25	0.26	0.32	0.51	0.63	0.69	0.44	0.61	0.51	0.99	1.83
2200	-0.01	0.25	0.28	0.37	0.58	0.70	0.77	0.52	0.69	0.64	1.19	2.14
2300	-0.01	0.25	0.30	0.41	0.64	0.78	0.84	0.59	0.78	0.77	1.40	2.45
2400	-0.02	0.26	0.31	0.45	0.70	0.85	0.91	0.67	0.87	0.91	1.63	2.77
2500	-0.01	0.26	0.33	0.49	0.76	0.91	0.98	0.74	0.96	1.07	1.86	3.11
2600	-0.01	0.27	0.34	0.52	0.80	0.97	1.05	0.82	1.06	1.24	2.13	3.49
2700	-0.01	0.27	0.35	0.54	0.84	1.03	1.12	0.91	1.20	1.47	2.49	3.97
2800	-0.01	0.27	0.37	0.60	0.95	1.18	1.32	1.19	1.59	2.04	3.20	4.80
2900	-0.01	0.28	0.40	0.68	1.08	1.35	1.52	1.44	1.88	2.36	3.53	5.09
3000	-0.01	0.28	0.40	0.67	1.07	1.34	1.50	1.40	1.84	2.32	3.50	5.05

Notes

- A. Performance and quality attributes and conditions not expressly stated in this specification document are intended to be excluded and do not form a part of this specification document.
- B. Electrical specifications and performance data contained in this specification document are based on Mini-Circuits' applicable established test performance criteria and measurement instructions.
- C. The parts covered by this specification document are subject to Mini-Circuits standard limited warranty and terms and conditions (collectively, "Standard Terms"); Purchasers of this part are entitled to the rights and benefits contained therein. For a full statement of the Standard Terms and the exclusive rights and remedies thereunder, please visit Mini-Circuits' website at www.minicircuits.com/MCLStore/terms.jsp



Programmable Attenuator

ZVVA-3000

Typical Performance Data @ 0°C

FREQUENCY (MHz)	Input VSWR (:1)											
	0.1 dB	1 dB	2.5 dB	5 dB	7.5 dB	10 dB	12.5 dB	15 dB	17.5 dB	20 dB	22.5 dB	25 dB
20	1.44	1.43	1.56	1.80	1.75	1.62	1.53	1.48	1.46	1.45	1.46	1.46
50	1.15	1.17	1.35	1.62	1.57	1.42	1.30	1.23	1.19	1.17	1.16	1.17
100	1.06	1.09	1.32	1.59	1.54	1.38	1.26	1.17	1.11	1.08	1.07	1.07
200	1.02	1.07	1.31	1.58	1.53	1.37	1.25	1.15	1.09	1.04	1.01	1.03
300	1.06	1.10	1.33	1.61	1.55	1.40	1.27	1.18	1.12	1.07	1.05	1.04
400	1.07	1.11	1.34	1.62	1.57	1.42	1.29	1.19	1.14	1.09	1.06	1.06
500	1.08	1.12	1.34	1.62	1.57	1.42	1.30	1.20	1.14	1.10	1.08	1.07
600	1.08	1.13	1.36	1.64	1.59	1.43	1.31	1.21	1.16	1.11	1.09	1.09
700	1.09	1.13	1.37	1.65	1.61	1.45	1.33	1.23	1.17	1.13	1.11	1.10
800	1.09	1.13	1.37	1.65	1.61	1.45	1.33	1.23	1.18	1.13	1.11	1.10
900	1.08	1.13	1.36	1.64	1.60	1.45	1.33	1.23	1.18	1.13	1.11	1.11
1000	1.08	1.14	1.38	1.66	1.61	1.46	1.34	1.24	1.18	1.14	1.11	1.10
1100	1.09	1.15	1.39	1.67	1.63	1.47	1.35	1.25	1.19	1.14	1.11	1.09
1200	1.09	1.15	1.40	1.68	1.63	1.48	1.36	1.25	1.19	1.14	1.11	1.09
1300	1.10	1.16	1.40	1.68	1.64	1.49	1.36	1.26	1.20	1.14	1.11	1.09
1400	1.11	1.17	1.40	1.68	1.64	1.49	1.36	1.26	1.19	1.14	1.10	1.08
1500	1.12	1.17	1.39	1.65	1.62	1.47	1.35	1.24	1.18	1.12	1.09	1.06
1600	1.12	1.17	1.38	1.63	1.59	1.45	1.33	1.23	1.16	1.11	1.07	1.04
1700	1.12	1.16	1.36	1.60	1.57	1.43	1.31	1.21	1.15	1.09	1.05	1.01
1800	1.12	1.16	1.35	1.57	1.54	1.41	1.29	1.20	1.14	1.08	1.04	1.01
1900	1.12	1.15	1.33	1.55	1.51	1.39	1.28	1.18	1.12	1.07	1.04	1.03
2000	1.11	1.14	1.31	1.52	1.49	1.37	1.26	1.17	1.12	1.07	1.04	1.05
2100	1.09	1.12	1.28	1.49	1.46	1.34	1.24	1.16	1.11	1.07	1.06	1.07
2200	1.07	1.10	1.26	1.45	1.43	1.32	1.22	1.14	1.10	1.07	1.07	1.10
2300	1.04	1.07	1.23	1.42	1.40	1.29	1.20	1.13	1.09	1.07	1.09	1.12
2400	1.01	1.05	1.21	1.39	1.37	1.27	1.18	1.11	1.08	1.08	1.10	1.14
2500	1.01	1.03	1.19	1.37	1.34	1.24	1.16	1.09	1.07	1.08	1.11	1.15
2600	1.04	1.04	1.17	1.34	1.32	1.23	1.14	1.08	1.06	1.09	1.12	1.17
2700	1.07	1.05	1.16	1.33	1.31	1.21	1.13	1.07	1.05	1.09	1.13	1.18
2800	1.09	1.07	1.16	1.31	1.29	1.20	1.11	1.05	1.05	1.10	1.14	1.19
2900	1.12	1.10	1.16	1.30	1.28	1.19	1.10	1.04	1.05	1.10	1.15	1.20
3000	1.13	1.11	1.17	1.30	1.28	1.19	1.11	1.04	1.05	1.10	1.15	1.19

Notes

- A. Performance and quality attributes and conditions not expressly stated in this specification document are intended to be excluded and do not form a part of this specification document.
- B. Electrical specifications and performance data contained in this specification document are based on Mini-Circuits' applicable established test performance criteria and measurement instructions.
- C. The parts covered by this specification document are subject to Mini-Circuits standard limited warranty and terms and conditions (collectively, "Standard Terms"); Purchasers of this part are entitled to the rights and benefits contained therein. For a full statement of the Standard Terms and the exclusive rights and remedies thereunder, please visit Mini-Circuits' website at www.minicircuits.com/MCLStore/terms.jsp



Programmable Attenuator

ZVVA-3000

Typical Performance Data @ 0°C

FREQUENCY (MHz)	Output VSWR (:1)											
	0.1 dB	1 dB	2.5 dB	5 dB	7.5 dB	10 dB	12.5 dB	15 dB	17.5 dB	20 dB	22.5 dB	25 dB
20	1.44	1.44	1.56	1.80	1.76	1.62	1.54	1.49	1.47	1.46	1.46	1.47
50	1.16	1.17	1.36	1.62	1.57	1.42	1.31	1.23	1.19	1.17	1.16	1.17
100	1.06	1.09	1.32	1.59	1.54	1.38	1.26	1.17	1.12	1.08	1.07	1.07
200	1.01	1.07	1.30	1.58	1.52	1.37	1.25	1.15	1.09	1.04	1.00	1.03
300	1.05	1.08	1.32	1.59	1.54	1.39	1.27	1.17	1.11	1.06	1.04	1.04
400	1.06	1.10	1.33	1.61	1.56	1.41	1.28	1.19	1.13	1.08	1.06	1.05
500	1.06	1.10	1.33	1.61	1.57	1.41	1.29	1.19	1.14	1.09	1.07	1.07
600	1.07	1.11	1.34	1.62	1.58	1.42	1.30	1.20	1.15	1.11	1.09	1.08
700	1.07	1.12	1.35	1.64	1.60	1.44	1.32	1.22	1.16	1.12	1.10	1.09
800	1.07	1.12	1.36	1.64	1.60	1.45	1.32	1.23	1.17	1.13	1.10	1.09
900	1.05	1.10	1.34	1.62	1.58	1.43	1.31	1.21	1.16	1.12	1.10	1.09
1000	1.04	1.10	1.34	1.62	1.58	1.43	1.31	1.21	1.16	1.11	1.09	1.08
1100	1.04	1.11	1.35	1.63	1.59	1.44	1.32	1.22	1.16	1.11	1.09	1.08
1200	1.05	1.11	1.35	1.64	1.60	1.45	1.33	1.23	1.16	1.11	1.09	1.07
1300	1.06	1.11	1.35	1.63	1.60	1.45	1.33	1.22	1.16	1.11	1.08	1.06
1400	1.07	1.12	1.34	1.62	1.59	1.44	1.32	1.22	1.15	1.10	1.07	1.05
1500	1.08	1.12	1.33	1.60	1.56	1.42	1.30	1.20	1.14	1.08	1.05	1.04
1600	1.09	1.12	1.32	1.57	1.54	1.40	1.28	1.19	1.12	1.07	1.03	1.02
1700	1.10	1.13	1.31	1.55	1.52	1.39	1.27	1.17	1.11	1.05	1.01	1.02
1800	1.11	1.13	1.30	1.53	1.50	1.37	1.25	1.16	1.10	1.04	1.01	1.04
1900	1.11	1.12	1.28	1.50	1.47	1.35	1.24	1.15	1.09	1.04	1.04	1.06
2000	1.11	1.11	1.26	1.47	1.44	1.32	1.22	1.13	1.08	1.05	1.06	1.09
2100	1.10	1.10	1.23	1.43	1.41	1.29	1.19	1.11	1.07	1.06	1.08	1.12
2200	1.09	1.08	1.20	1.40	1.38	1.27	1.17	1.10	1.07	1.08	1.11	1.14
2300	1.08	1.06	1.17	1.36	1.34	1.24	1.15	1.08	1.07	1.09	1.13	1.17
2400	1.07	1.04	1.15	1.33	1.31	1.21	1.12	1.07	1.07	1.11	1.15	1.20
2500	1.08	1.04	1.12	1.30	1.28	1.19	1.10	1.06	1.08	1.13	1.17	1.22
2600	1.09	1.05	1.11	1.28	1.26	1.16	1.08	1.05	1.09	1.14	1.19	1.24
2700	1.11	1.07	1.10	1.26	1.24	1.15	1.06	1.05	1.09	1.15	1.21	1.26
2800	1.13	1.09	1.10	1.25	1.22	1.13	1.04	1.05	1.11	1.17	1.22	1.28
2900	1.16	1.12	1.10	1.23	1.21	1.11	1.03	1.06	1.12	1.19	1.24	1.30
3000	1.18	1.14	1.11	1.23	1.20	1.11	1.02	1.06	1.12	1.19	1.25	1.30

Notes

- A. Performance and quality attributes and conditions not expressly stated in this specification document are intended to be excluded and do not form a part of this specification document.
- B. Electrical specifications and performance data contained in this specification document are based on Mini-Circuits' applicable established test performance criteria and measurement instructions.
- C. The parts covered by this specification document are subject to Mini-Circuits standard limited warranty and terms and conditions (collectively, "Standard Terms"); Purchasers of this part are entitled to the rights and benefits contained therein. For a full statement of the Standard Terms and the exclusive rights and remedies thereunder, please visit Mini-Circuits' website at www.minicircuits.com/MCLStore/terms.jsp



Programmable Attenuator

ZVVA-3000

Typical Performance Data @ 0°C

FREQUENCY (MHz)	IP3 (dBm)
20	50.38
50	54.82
100	52.44
250	53.26
500	52.10
750	52.38
1000	51.46
1250	52.41
1500	52.14
1750	52.38
2000	52.47
2250	52.28
2500	52.50
2750	52.84
3000	51.15

Notes

- A. Performance and quality attributes and conditions not expressly stated in this specification document are intended to be excluded and do not form a part of this specification document.
- B. Electrical specifications and performance data contained in this specification document are based on Mini-Circuits' applicable established test performance criteria and measurement instructions.
- C. The parts covered by this specification document are subject to Mini-Circuits standard limited warranty and terms and conditions (collectively, "Standard Terms"). Purchasers of this part are entitled to the rights and benefits contained therein. For a full statement of the Standard Terms and the exclusive rights and remedies thereunder, please visit Mini-Circuits' website at www.minicircuits.com/MCLStore/terms.jsp



Programmable Attenuator

ZVVA-3000

Typical Performance Data @ +25°C

FREQUENCY (MHz)	Attenuation relative to Insertion Loss (dB)											
	0.1 dB	1 dB	2.5 dB	5 dB	7.5 dB	10 dB	12.5 dB	15 dB	17.5 dB	20 dB	22.5 dB	25 dB
20	0.12	0.96	2.45	5.11	7.89	10.63	13.23	15.98	18.26	20.91	23.34	26.12
50	0.12	0.94	2.43	5.09	7.88	10.63	13.23	15.98	18.27	20.93	23.37	26.17
100	0.12	0.94	2.45	5.12	7.90	10.63	13.22	15.96	18.24	20.90	23.34	26.14
200	0.12	0.94	2.45	5.13	7.89	10.61	13.19	15.92	18.20	20.86	23.30	26.09
300	0.12	0.94	2.46	5.13	7.88	10.59	13.16	15.89	18.17	20.82	23.25	26.03
400	0.12	0.93	2.46	5.14	7.88	10.57	13.13	15.86	18.13	20.78	23.21	25.97
500	0.12	0.93	2.47	5.15	7.87	10.55	13.10	15.82	18.09	20.74	23.16	25.90
600	0.12	0.93	2.47	5.15	7.86	10.52	13.06	15.77	18.05	20.69	23.11	25.82
700	0.12	0.93	2.48	5.16	7.85	10.49	13.02	15.73	18.00	20.64	23.05	25.72
800	0.12	0.93	2.49	5.16	7.83	10.45	12.97	15.67	17.94	20.58	22.97	25.60
900	0.12	0.93	2.49	5.16	7.80	10.41	12.92	15.61	17.88	20.51	22.89	25.46
1000	0.12	0.93	2.48	5.13	7.75	10.34	12.84	15.53	17.80	20.43	22.78	25.30
1100	0.12	0.94	2.47	5.11	7.72	10.29	12.78	15.48	17.74	20.36	22.69	25.13
1200	0.12	0.93	2.47	5.10	7.69	10.25	12.73	15.43	17.69	20.30	22.60	24.97
1300	0.11	0.93	2.46	5.07	7.64	10.19	12.67	15.36	17.62	20.21	22.48	24.76
1400	0.11	0.91	2.43	5.03	7.58	10.11	12.58	15.27	17.52	20.09	22.30	24.47
1500	0.11	0.91	2.40	4.96	7.48	9.98	12.43	15.10	17.32	19.85	22.00	24.08
1600	0.11	0.90	2.38	4.90	7.39	9.88	12.33	15.00	17.23	19.75	21.87	23.89
1700	0.12	0.90	2.36	4.86	7.32	9.81	12.26	14.93	17.17	19.69	21.78	23.73
1800	0.12	0.90	2.34	4.81	7.25	9.73	12.19	14.88	17.12	19.62	21.66	23.51
1900	0.12	0.90	2.32	4.76	7.19	9.66	12.12	14.81	17.05	19.52	21.51	23.27
2000	0.12	0.89	2.30	4.71	7.12	9.59	12.05	14.74	16.98	19.42	21.34	23.00
2100	0.12	0.89	2.28	4.66	7.06	9.52	11.97	14.67	16.90	19.30	21.16	22.73
2200	0.12	0.89	2.26	4.62	6.99	9.44	11.90	14.60	16.81	19.18	20.97	22.45
2300	0.13	0.88	2.24	4.58	6.93	9.38	11.84	14.53	16.74	19.06	20.79	22.18
2400	0.13	0.88	2.22	4.54	6.87	9.31	11.77	14.47	16.65	18.93	20.58	21.88
2500	0.13	0.87	2.21	4.50	6.82	9.25	11.71	14.40	16.56	18.78	20.36	21.57
2600	0.12	0.87	2.19	4.47	6.77	9.19	11.65	14.33	16.46	18.62	20.11	21.22
2700	0.13	0.87	2.18	4.44	6.73	9.13	11.57	14.23	16.32	18.37	19.75	20.74
2800	0.12	0.86	2.16	4.37	6.61	8.96	11.35	13.91	15.90	17.81	19.06	19.96
2900	0.12	0.85	2.13	4.31	6.51	8.84	11.20	13.75	15.71	17.59	18.85	19.78
3000	0.13	0.85	2.14	4.32	6.52	8.85	11.22	13.77	15.74	17.61	18.86	19.77

Notes

- A. Performance and quality attributes and conditions not expressly stated in this specification document are intended to be excluded and do not form a part of this specification document.
- B. Electrical specifications and performance data contained in this specification document are based on Mini-Circuits' applicable established test performance criteria and measurement instructions.
- C. The parts covered by this specification document are subject to Mini-Circuits standard limited warranty and terms and conditions (collectively, "Standard Terms"); Purchasers of this part are entitled to the rights and benefits contained therein. For a full statement of the Standard Terms and the exclusive rights and remedies thereunder, please visit Mini-Circuits' website at www.minicircuits.com/MCLStore/terms.jsp



Programmable Attenuator

ZVVA-3000

Typical Performance Data @ +25°C

FREQUENCY (MHz)	Attenuation accuracy relative to nominal attenuation setting (dB)											
	0.1 dB	1 dB	2.5 dB	5 dB	7.5 dB	10 dB	12.5 dB	15 dB	17.5 dB	20 dB	22.5 dB	25 dB
20	-0.02	0.04	0.05	-0.11	-0.39	-0.63	-0.73	-0.98	-0.76	-0.91	-0.84	-1.12
50	-0.02	0.06	0.07	-0.09	-0.38	-0.63	-0.73	-0.98	-0.77	-0.93	-0.87	-1.17
100	-0.02	0.06	0.05	-0.12	-0.40	-0.63	-0.72	-0.96	-0.74	-0.90	-0.84	-1.14
200	-0.02	0.06	0.05	-0.13	-0.39	-0.61	-0.69	-0.92	-0.70	-0.86	-0.80	-1.08
300	-0.02	0.07	0.04	-0.13	-0.38	-0.59	-0.66	-0.89	-0.67	-0.82	-0.75	-1.03
400	-0.02	0.07	0.04	-0.14	-0.38	-0.57	-0.63	-0.85	-0.63	-0.78	-0.71	-0.97
500	-0.02	0.07	0.03	-0.15	-0.37	-0.55	-0.60	-0.82	-0.59	-0.74	-0.66	-0.90
600	-0.02	0.07	0.03	-0.15	-0.36	-0.52	-0.56	-0.77	-0.55	-0.69	-0.61	-0.82
700	-0.02	0.07	0.02	-0.16	-0.34	-0.49	-0.52	-0.73	-0.50	-0.64	-0.55	-0.72
800	-0.02	0.07	0.01	-0.16	-0.33	-0.45	-0.47	-0.67	-0.44	-0.58	-0.47	-0.60
900	-0.02	0.07	0.01	-0.16	-0.30	-0.41	-0.42	-0.61	-0.38	-0.51	-0.39	-0.46
1000	-0.02	0.07	0.02	-0.13	-0.25	-0.34	-0.34	-0.53	-0.30	-0.43	-0.28	-0.30
1100	-0.02	0.07	0.03	-0.11	-0.22	-0.29	-0.28	-0.48	-0.24	-0.36	-0.19	-0.13
1200	-0.02	0.07	0.03	-0.09	-0.19	-0.25	-0.23	-0.43	-0.19	-0.30	-0.10	0.03
1300	-0.01	0.07	0.05	-0.07	-0.14	-0.19	-0.17	-0.36	-0.12	-0.21	0.02	0.24
1400	-0.01	0.09	0.07	-0.03	-0.08	-0.11	-0.08	-0.27	-0.02	-0.09	0.20	0.53
1500	-0.01	0.10	0.10	0.04	0.03	0.02	0.07	-0.10	0.18	0.15	0.50	0.92
1600	-0.01	0.10	0.12	0.10	0.11	0.12	0.17	0.01	0.27	0.25	0.63	1.11
1700	-0.02	0.10	0.14	0.15	0.18	0.19	0.24	0.07	0.33	0.31	0.72	1.27
1800	-0.02	0.10	0.16	0.19	0.25	0.27	0.31	0.12	0.38	0.38	0.84	1.49
1900	-0.02	0.10	0.18	0.24	0.31	0.34	0.38	0.19	0.45	0.48	0.99	1.73
2000	-0.02	0.11	0.20	0.29	0.38	0.41	0.45	0.26	0.52	0.58	1.16	2.00
2100	-0.02	0.11	0.22	0.34	0.45	0.48	0.53	0.33	0.60	0.70	1.34	2.27
2200	-0.02	0.12	0.24	0.39	0.51	0.56	0.60	0.40	0.69	0.82	1.53	2.55
2300	-0.03	0.12	0.26	0.43	0.57	0.63	0.66	0.47	0.76	0.94	1.72	2.83
2400	-0.03	0.12	0.28	0.47	0.63	0.69	0.73	0.53	0.85	1.08	1.92	3.12
2500	-0.03	0.13	0.29	0.50	0.68	0.75	0.79	0.60	0.94	1.22	2.14	3.43
2600	-0.02	0.13	0.31	0.53	0.73	0.81	0.85	0.68	1.04	1.38	2.39	3.78
2700	-0.03	0.14	0.32	0.56	0.77	0.87	0.93	0.77	1.18	1.63	2.75	4.26
2800	-0.02	0.14	0.34	0.63	0.89	1.04	1.15	1.09	1.60	2.19	3.44	5.04
2900	-0.02	0.15	0.37	0.69	0.99	1.16	1.30	1.26	1.79	2.41	3.65	5.22
3000	-0.03	0.15	0.36	0.68	0.98	1.16	1.28	1.23	1.76	2.39	3.64	5.23

Notes

- A. Performance and quality attributes and conditions not expressly stated in this specification document are intended to be excluded and do not form a part of this specification document.
- B. Electrical specifications and performance data contained in this specification document are based on Mini-Circuits' applicable established test performance criteria and measurement instructions.
- C. The parts covered by this specification document are subject to Mini-Circuits standard limited warranty and terms and conditions (collectively, "Standard Terms"); Purchasers of this part are entitled to the rights and benefits contained therein. For a full statement of the Standard Terms and the exclusive rights and remedies thereunder, please visit Mini-Circuits' website at www.minicircuits.com/MCLStore/terms.jsp



Programmable Attenuator

ZVVA-3000

Typical Performance Data @ +25°C

FREQUENCY (MHz)	Input VSWR (:1)											
	0.1 dB	1 dB	2.5 dB	5 dB	7.5 dB	10 dB	12.5 dB	15 dB	17.5 dB	20 dB	22.5 dB	25 dB
20	1.43	1.42	1.53	1.74	1.69	1.57	1.50	1.46	1.44	1.44	1.44	1.45
50	1.15	1.16	1.33	1.57	1.51	1.37	1.27	1.20	1.17	1.16	1.16	1.16
100	1.05	1.09	1.30	1.54	1.49	1.34	1.23	1.14	1.10	1.07	1.06	1.07
200	1.01	1.08	1.29	1.54	1.49	1.34	1.22	1.13	1.08	1.03	1.01	1.03
300	1.03	1.09	1.30	1.55	1.49	1.35	1.23	1.14	1.09	1.04	1.03	1.04
400	1.05	1.10	1.31	1.56	1.50	1.36	1.24	1.15	1.10	1.06	1.05	1.05
500	1.07	1.11	1.32	1.56	1.51	1.37	1.25	1.17	1.12	1.08	1.07	1.07
600	1.07	1.12	1.33	1.58	1.53	1.38	1.27	1.18	1.13	1.09	1.08	1.07
700	1.07	1.13	1.34	1.59	1.54	1.40	1.28	1.19	1.14	1.11	1.09	1.08
800	1.08	1.14	1.35	1.60	1.55	1.41	1.29	1.20	1.15	1.12	1.10	1.09
900	1.06	1.13	1.34	1.59	1.54	1.40	1.29	1.20	1.15	1.11	1.10	1.09
1000	1.06	1.14	1.35	1.60	1.55	1.41	1.29	1.20	1.15	1.11	1.09	1.08
1100	1.06	1.14	1.36	1.61	1.56	1.42	1.30	1.21	1.16	1.11	1.09	1.07
1200	1.07	1.15	1.36	1.61	1.57	1.43	1.31	1.21	1.16	1.11	1.08	1.07
1300	1.08	1.15	1.37	1.61	1.57	1.43	1.31	1.22	1.16	1.11	1.08	1.06
1400	1.09	1.16	1.36	1.60	1.56	1.42	1.31	1.21	1.15	1.10	1.07	1.05
1500	1.10	1.16	1.35	1.58	1.54	1.41	1.29	1.20	1.14	1.09	1.06	1.03
1600	1.10	1.16	1.34	1.57	1.53	1.39	1.28	1.19	1.13	1.08	1.04	1.01
1700	1.11	1.16	1.33	1.55	1.51	1.38	1.27	1.18	1.12	1.07	1.04	1.01
1800	1.11	1.16	1.32	1.52	1.49	1.36	1.26	1.17	1.12	1.07	1.04	1.03
1900	1.11	1.15	1.31	1.50	1.47	1.35	1.24	1.16	1.11	1.06	1.04	1.05
2000	1.10	1.14	1.29	1.47	1.44	1.33	1.23	1.15	1.10	1.07	1.06	1.07
2100	1.08	1.12	1.26	1.44	1.41	1.31	1.21	1.14	1.10	1.07	1.07	1.09
2200	1.06	1.10	1.24	1.41	1.39	1.28	1.20	1.13	1.09	1.08	1.09	1.11
2300	1.04	1.08	1.21	1.38	1.36	1.26	1.18	1.11	1.09	1.09	1.10	1.13
2400	1.02	1.05	1.19	1.35	1.33	1.24	1.16	1.10	1.08	1.09	1.12	1.15
2500	1.02	1.03	1.17	1.33	1.31	1.22	1.14	1.09	1.08	1.10	1.13	1.16
2600	1.04	1.03	1.15	1.31	1.29	1.20	1.12	1.08	1.08	1.11	1.14	1.18
2700	1.07	1.04	1.14	1.29	1.27	1.18	1.11	1.06	1.07	1.11	1.15	1.19
2800	1.09	1.06	1.14	1.27	1.25	1.16	1.09	1.05	1.07	1.12	1.16	1.20
2900	1.12	1.09	1.14	1.26	1.24	1.15	1.08	1.05	1.07	1.12	1.16	1.21
3000	1.14	1.10	1.14	1.26	1.24	1.16	1.08	1.04	1.07	1.12	1.16	1.21

Notes

- A. Performance and quality attributes and conditions not expressly stated in this specification document are intended to be excluded and do not form a part of this specification document.
- B. Electrical specifications and performance data contained in this specification document are based on Mini-Circuits' applicable established test performance criteria and measurement instructions.
- C. The parts covered by this specification document are subject to Mini-Circuits standard limited warranty and terms and conditions (collectively, "Standard Terms"); Purchasers of this part are entitled to the rights and benefits contained therein. For a full statement of the Standard Terms and the exclusive rights and remedies thereunder, please visit Mini-Circuits' website at www.minicircuits.com/MCLStore/terms.jsp



Programmable Attenuator

ZVVA-3000

Typical Performance Data @ +25°C

FREQUENCY (MHz)	Output VSWR (:1)											
	0.1 dB	1 dB	2.5 dB	5 dB	7.5 dB	10 dB	12.5 dB	15 dB	17.5 dB	20 dB	22.5 dB	25 dB
20	1.44	1.43	1.54	1.74	1.70	1.58	1.50	1.46	1.45	1.45	1.45	1.46
50	1.15	1.16	1.33	1.56	1.51	1.37	1.27	1.20	1.17	1.16	1.16	1.16
100	1.06	1.09	1.29	1.54	1.49	1.34	1.23	1.14	1.10	1.07	1.06	1.07
200	1.01	1.07	1.29	1.53	1.48	1.33	1.22	1.13	1.07	1.03	1.01	1.04
300	1.03	1.08	1.29	1.54	1.49	1.34	1.22	1.13	1.08	1.04	1.02	1.04
400	1.04	1.09	1.30	1.55	1.49	1.35	1.23	1.15	1.09	1.05	1.04	1.05
500	1.05	1.10	1.30	1.55	1.50	1.36	1.24	1.16	1.11	1.07	1.06	1.06
600	1.05	1.10	1.31	1.56	1.51	1.37	1.26	1.17	1.12	1.08	1.07	1.07
700	1.05	1.11	1.32	1.57	1.53	1.38	1.27	1.18	1.13	1.09	1.08	1.08
800	1.05	1.11	1.32	1.58	1.53	1.39	1.27	1.19	1.14	1.10	1.08	1.08
900	1.04	1.10	1.31	1.56	1.52	1.38	1.27	1.18	1.13	1.10	1.08	1.08
1000	1.03	1.10	1.32	1.57	1.53	1.39	1.27	1.18	1.13	1.09	1.07	1.07
1100	1.03	1.11	1.33	1.58	1.53	1.39	1.28	1.19	1.13	1.09	1.07	1.06
1200	1.04	1.11	1.33	1.58	1.54	1.40	1.28	1.19	1.13	1.09	1.06	1.05
1300	1.05	1.12	1.32	1.57	1.53	1.39	1.28	1.18	1.13	1.08	1.05	1.04
1400	1.06	1.12	1.32	1.56	1.52	1.39	1.27	1.18	1.12	1.07	1.04	1.03
1500	1.08	1.12	1.30	1.54	1.50	1.37	1.26	1.16	1.11	1.06	1.02	1.02
1600	1.09	1.12	1.29	1.52	1.48	1.35	1.24	1.15	1.10	1.04	1.01	1.03
1700	1.10	1.13	1.28	1.49	1.46	1.33	1.23	1.14	1.09	1.04	1.02	1.04
1800	1.11	1.12	1.27	1.47	1.44	1.32	1.21	1.13	1.08	1.04	1.04	1.06
1900	1.11	1.12	1.25	1.44	1.41	1.30	1.20	1.12	1.07	1.05	1.06	1.09
2000	1.11	1.11	1.23	1.41	1.39	1.27	1.18	1.11	1.07	1.06	1.08	1.11
2100	1.10	1.10	1.20	1.38	1.36	1.25	1.16	1.10	1.07	1.08	1.11	1.14
2200	1.10	1.08	1.18	1.35	1.33	1.23	1.14	1.09	1.08	1.10	1.13	1.16
2300	1.09	1.06	1.15	1.32	1.30	1.20	1.12	1.08	1.09	1.12	1.15	1.19
2400	1.09	1.05	1.13	1.29	1.27	1.18	1.10	1.08	1.10	1.14	1.17	1.21
2500	1.10	1.04	1.10	1.26	1.24	1.15	1.09	1.08	1.11	1.15	1.19	1.24
2600	1.11	1.05	1.08	1.24	1.22	1.13	1.07	1.07	1.12	1.17	1.21	1.26
2700	1.13	1.07	1.07	1.22	1.20	1.11	1.05	1.07	1.12	1.18	1.22	1.27
2800	1.14	1.09	1.07	1.21	1.18	1.09	1.03	1.08	1.13	1.19	1.24	1.29
2900	1.16	1.11	1.08	1.19	1.17	1.08	1.02	1.09	1.14	1.21	1.26	1.31
3000	1.18	1.13	1.10	1.19	1.16	1.08	1.02	1.08	1.14	1.21	1.26	1.31

Notes

- A. Performance and quality attributes and conditions not expressly stated in this specification document are intended to be excluded and do not form a part of this specification document.
- B. Electrical specifications and performance data contained in this specification document are based on Mini-Circuits' applicable established test performance criteria and measurement instructions.
- C. The parts covered by this specification document are subject to Mini-Circuits standard limited warranty and terms and conditions (collectively, "Standard Terms"); Purchasers of this part are entitled to the rights and benefits contained therein. For a full statement of the Standard Terms and the exclusive rights and remedies thereunder, please visit Mini-Circuits' website at www.minicircuits.com/MCLStore/terms.jsp



Programmable Attenuator

ZVVA-3000

Typical Performance Data @ +25°C

FREQUENCY (MHz)	IP3 (dBm)
20	50.42
50	52.31
100	52.47
250	52.26
500	51.88
750	51.49
1000	51.42
1250	52.56
1500	51.74
1750	51.49
2000	52.31
2250	51.40
2500	52.36
2750	51.49
3000	51.32

Notes

- A. Performance and quality attributes and conditions not expressly stated in this specification document are intended to be excluded and do not form a part of this specification document.
B. Electrical specifications and performance data contained in this specification document are based on Mini-Circuits' applicable established test performance criteria and measurement instructions.
C. The parts covered by this specification document are subject to Mini-Circuits standard limited warranty and terms and conditions (collectively, "Standard Terms"). Purchasers of this part are entitled to the rights and benefits contained therein. For a full statement of the Standard Terms and the exclusive rights and remedies thereunder, please visit Mini-Circuits' website at www.minicircuits.com/MCLStore/terms.jsp



Programmable Attenuator

ZVVA-3000

Typical Performance Data @ +50°C

FREQUENCY (MHz)	Attenuation relative to Insertion Loss (dB)											
	0.1 dB	1 dB	2.5 dB	5 dB	7.5 dB	10 dB	12.5 dB	15 dB	17.5 dB	20 dB	22.5 dB	25 dB
20	0.11	0.82	2.40	5.11	7.83	10.53	13.14	15.97	18.37	21.26	23.99	27.24
50	0.11	0.79	2.38	5.09	7.82	10.52	13.14	15.97	18.39	21.28	24.04	27.32
100	0.11	0.79	2.39	5.11	7.82	10.52	13.12	15.94	18.36	21.25	24.01	27.29
200	0.11	0.79	2.39	5.11	7.81	10.49	13.08	15.90	18.31	21.21	23.96	27.23
300	0.11	0.79	2.41	5.14	7.83	10.49	13.07	15.87	18.28	21.17	23.92	27.17
400	0.11	0.78	2.42	5.16	7.83	10.48	13.04	15.84	18.24	21.13	23.87	27.09
500	0.11	0.78	2.43	5.17	7.83	10.45	13.01	15.80	18.20	21.08	23.81	27.00
600	0.11	0.78	2.43	5.17	7.81	10.42	12.96	15.75	18.15	21.03	23.74	26.89
700	0.11	0.78	2.44	5.18	7.80	10.39	12.92	15.70	18.09	20.96	23.67	26.75
800	0.11	0.78	2.44	5.18	7.78	10.35	12.87	15.64	18.03	20.90	23.59	26.60
900	0.11	0.78	2.44	5.17	7.75	10.30	12.81	15.57	17.96	20.82	23.48	26.42
1000	0.11	0.78	2.43	5.14	7.70	10.23	12.73	15.49	17.87	20.72	23.36	26.21
1100	0.11	0.78	2.43	5.13	7.66	10.18	12.67	15.42	17.81	20.65	23.24	26.00
1200	0.11	0.78	2.43	5.12	7.64	10.14	12.62	15.38	17.76	20.58	23.14	25.79
1300	0.10	0.78	2.42	5.10	7.60	10.08	12.55	15.30	17.68	20.49	23.00	25.53
1400	0.10	0.77	2.40	5.06	7.54	10.01	12.47	15.21	17.58	20.36	22.80	25.20
1500	0.10	0.76	2.37	4.99	7.43	9.87	12.30	15.02	17.35	20.08	22.44	24.72
1600	0.10	0.76	2.35	4.93	7.34	9.77	12.19	14.91	17.25	19.98	22.32	24.52
1700	0.11	0.76	2.33	4.88	7.27	9.68	12.12	14.85	17.20	19.92	22.22	24.33
1800	0.11	0.76	2.31	4.83	7.20	9.61	12.04	14.78	17.14	19.84	22.08	24.07
1900	0.11	0.76	2.28	4.78	7.13	9.53	11.97	14.71	17.06	19.73	21.90	23.78
2000	0.11	0.75	2.26	4.73	7.06	9.45	11.89	14.63	16.98	19.62	21.71	23.48
2100	0.11	0.75	2.24	4.68	6.99	9.37	11.81	14.56	16.89	19.49	21.51	23.17
2200	0.11	0.75	2.22	4.63	6.92	9.30	11.73	14.48	16.81	19.36	21.31	22.86
2300	0.11	0.75	2.20	4.59	6.86	9.22	11.66	14.41	16.72	19.23	21.10	22.55
2400	0.12	0.74	2.19	4.55	6.80	9.15	11.59	14.33	16.63	19.09	20.88	22.23
2500	0.11	0.74	2.17	4.51	6.74	9.09	11.52	14.26	16.54	18.93	20.64	21.89
2600	0.11	0.74	2.16	4.48	6.70	9.03	11.45	14.18	16.44	18.76	20.37	21.52
2700	0.11	0.73	2.15	4.46	6.66	8.97	11.39	14.09	16.30	18.53	20.01	21.03
2800	0.11	0.73	2.13	4.40	6.55	8.82	11.18	13.81	15.91	17.97	19.30	20.20
2900	0.11	0.72	2.10	4.32	6.42	8.66	10.98	13.56	15.62	17.64	18.97	19.91
3000	0.11	0.72	2.10	4.33	6.43	8.66	11.00	13.60	15.66	17.68	19.00	19.95

Notes

- A. Performance and quality attributes and conditions not expressly stated in this specification document are intended to be excluded and do not form a part of this specification document.
- B. Electrical specifications and performance data contained in this specification document are based on Mini-Circuits' applicable established test performance criteria and measurement instructions.
- C. The parts covered by this specification document are subject to Mini-Circuits standard limited warranty and terms and conditions (collectively, "Standard Terms"). Purchasers of this part are entitled to the rights and benefits contained therein. For a full statement of the Standard Terms and the exclusive rights and remedies thereunder, please visit Mini-Circuits' website at www.minicircuits.com/MCLStore/terms.jsp



Programmable Attenuator

ZVVA-3000

Typical Performance Data @ +50°C

FREQUENCY (MHz)	Attenuation accuracy relative to nominal attenuation setting (dB)											
	0.1 dB	1 dB	2.5 dB	5 dB	7.5 dB	10 dB	12.5 dB	15 dB	17.5 dB	20 dB	22.5 dB	25 dB
20	-0.03	-0.10	0.00	-0.11	-0.45	-0.73	-0.81	-0.98	-0.64	-0.60	-0.29	-0.22
50	-0.03	-0.09	0.01	-0.10	-0.44	-0.73	-0.81	-0.98	-0.65	-0.61	-0.31	-0.25
100	-0.03	-0.09	-0.01	-0.13	-0.46	-0.73	-0.80	-0.96	-0.62	-0.58	-0.28	-0.21
200	-0.03	-0.09	-0.02	-0.14	-0.46	-0.71	-0.77	-0.93	-0.59	-0.54	-0.24	-0.16
300	-0.03	-0.09	-0.01	-0.14	-0.45	-0.69	-0.74	-0.89	-0.55	-0.50	-0.20	-0.12
400	-0.03	-0.08	-0.01	-0.14	-0.43	-0.66	-0.71	-0.86	-0.52	-0.47	-0.16	-0.08
500	-0.03	-0.08	-0.02	-0.15	-0.43	-0.64	-0.68	-0.82	-0.48	-0.43	-0.12	-0.02
600	-0.03	-0.08	-0.02	-0.14	-0.41	-0.61	-0.64	-0.78	-0.44	-0.39	-0.08	0.04
700	-0.03	-0.08	-0.03	-0.14	-0.39	-0.58	-0.60	-0.74	-0.39	-0.34	-0.02	0.12
800	-0.03	-0.08	-0.03	-0.15	-0.38	-0.55	-0.56	-0.69	-0.35	-0.29	0.04	0.21
900	-0.03	-0.09	-0.03	-0.14	-0.34	-0.50	-0.50	-0.63	-0.28	-0.23	0.11	0.32
1000	-0.03	-0.08	-0.02	-0.11	-0.30	-0.44	-0.43	-0.56	-0.22	-0.16	0.20	0.45
1100	-0.03	-0.08	-0.02	-0.09	-0.26	-0.39	-0.38	-0.51	-0.16	-0.10	0.28	0.58
1200	-0.03	-0.08	-0.01	-0.08	-0.23	-0.35	-0.33	-0.46	-0.12	-0.04	0.36	0.71
1300	-0.02	-0.08	0.00	-0.05	-0.19	-0.29	-0.27	-0.40	-0.05	0.03	0.46	0.88
1400	-0.02	-0.06	0.02	-0.01	-0.13	-0.21	-0.19	-0.31	0.05	0.16	0.63	1.14
1500	-0.02	-0.05	0.05	0.05	-0.03	-0.10	-0.05	-0.16	0.21	0.35	0.87	1.45
1600	-0.02	-0.05	0.07	0.11	0.05	0.00	0.05	-0.06	0.31	0.45	1.00	1.63
1700	-0.03	-0.05	0.09	0.15	0.12	0.07	0.12	0.00	0.36	0.51	1.08	1.78
1800	-0.03	-0.04	0.11	0.20	0.18	0.14	0.18	0.05	0.40	0.57	1.19	1.96
1900	-0.03	-0.04	0.14	0.25	0.25	0.21	0.24	0.10	0.46	0.66	1.32	2.17
2000	-0.03	-0.03	0.16	0.30	0.31	0.28	0.31	0.17	0.53	0.75	1.47	2.39
2100	-0.04	-0.03	0.18	0.35	0.38	0.35	0.37	0.23	0.61	0.86	1.63	2.63
2200	-0.04	-0.02	0.20	0.39	0.44	0.42	0.44	0.30	0.68	0.97	1.79	2.88
2300	-0.04	-0.01	0.22	0.43	0.50	0.48	0.50	0.36	0.75	1.08	1.97	3.13
2400	-0.04	-0.01	0.24	0.47	0.56	0.55	0.56	0.42	0.83	1.20	2.15	3.39
2500	-0.04	0.00	0.25	0.51	0.61	0.60	0.62	0.49	0.92	1.34	2.35	3.68
2600	-0.04	0.00	0.27	0.54	0.66	0.66	0.68	0.55	1.01	1.49	2.58	4.00
2700	-0.04	0.01	0.28	0.57	0.71	0.73	0.76	0.67	1.18	1.75	2.96	4.49
2800	-0.04	0.02	0.31	0.65	0.84	0.91	1.00	0.98	1.59	2.29	3.59	5.20
2900	-0.04	0.02	0.33	0.69	0.91	0.99	1.10	1.10	1.72	2.43	3.73	5.32
3000	-0.04	0.02	0.32	0.68	0.90	0.99	1.08	1.08	1.70	2.43	3.75	5.35

Notes

- A. Performance and quality attributes and conditions not expressly stated in this specification document are intended to be excluded and do not form a part of this specification document.
- B. Electrical specifications and performance data contained in this specification document are based on Mini-Circuits' applicable established test performance criteria and measurement instructions.
- C. The parts covered by this specification document are subject to Mini-Circuits standard limited warranty and terms and conditions (collectively, "Standard Terms"); Purchasers of this part are entitled to the rights and benefits contained therein. For a full statement of the Standard Terms and the exclusive rights and remedies thereunder, please visit Mini-Circuits' website at www.minicircuits.com/MCLStore/terms.jsp



Programmable Attenuator

ZVVA-3000

Typical Performance Data @ +50°C

FREQUENCY (MHz)	Input VSWR (:1)											
	0.1 dB	1 dB	2.5 dB	5 dB	7.5 dB	10 dB	12.5 dB	15 dB	17.5 dB	20 dB	22.5 dB	25 dB
20	1.42	1.42	1.51	1.69	1.64	1.53	1.47	1.44	1.43	1.43	1.44	1.44
50	1.14	1.16	1.30	1.51	1.46	1.33	1.24	1.18	1.16	1.15	1.15	1.16
100	1.05	1.09	1.28	1.49	1.44	1.30	1.20	1.12	1.08	1.06	1.06	1.07
200	1.02	1.08	1.27	1.50	1.44	1.30	1.20	1.11	1.06	1.02	1.01	1.04
300	1.03	1.08	1.27	1.49	1.44	1.30	1.20	1.11	1.06	1.02	1.02	1.04
400	1.04	1.10	1.28	1.50	1.45	1.31	1.20	1.12	1.08	1.04	1.04	1.05
500	1.06	1.11	1.29	1.51	1.45	1.32	1.21	1.13	1.09	1.06	1.06	1.07
600	1.06	1.11	1.30	1.52	1.47	1.33	1.22	1.14	1.10	1.07	1.06	1.07
700	1.06	1.12	1.31	1.53	1.48	1.34	1.24	1.16	1.11	1.08	1.07	1.08
800	1.06	1.13	1.32	1.54	1.49	1.35	1.25	1.17	1.12	1.09	1.08	1.08
900	1.05	1.13	1.31	1.53	1.49	1.35	1.25	1.17	1.12	1.09	1.08	1.08
1000	1.04	1.14	1.32	1.54	1.50	1.36	1.25	1.17	1.12	1.09	1.07	1.07
1100	1.05	1.14	1.33	1.55	1.51	1.37	1.26	1.18	1.13	1.09	1.07	1.06
1200	1.05	1.15	1.34	1.56	1.51	1.38	1.27	1.18	1.13	1.09	1.06	1.05
1300	1.06	1.15	1.34	1.56	1.51	1.38	1.27	1.18	1.13	1.09	1.06	1.04
1400	1.07	1.16	1.34	1.55	1.51	1.37	1.27	1.18	1.13	1.08	1.05	1.03
1500	1.08	1.16	1.33	1.53	1.49	1.36	1.26	1.17	1.12	1.07	1.04	1.02
1600	1.10	1.16	1.32	1.52	1.48	1.35	1.25	1.16	1.11	1.06	1.03	1.00
1700	1.10	1.16	1.31	1.50	1.46	1.34	1.24	1.16	1.11	1.06	1.03	1.02
1800	1.11	1.16	1.30	1.48	1.45	1.33	1.23	1.15	1.10	1.06	1.04	1.04
1900	1.11	1.16	1.29	1.46	1.43	1.31	1.22	1.15	1.10	1.07	1.06	1.07
2000	1.10	1.14	1.27	1.43	1.40	1.29	1.21	1.14	1.10	1.08	1.08	1.09
2100	1.09	1.12	1.24	1.40	1.37	1.27	1.19	1.13	1.10	1.09	1.09	1.11
2200	1.07	1.10	1.22	1.37	1.34	1.25	1.17	1.12	1.10	1.10	1.11	1.13
2300	1.05	1.08	1.19	1.34	1.32	1.23	1.16	1.11	1.10	1.11	1.13	1.15
2400	1.04	1.05	1.17	1.32	1.29	1.21	1.14	1.10	1.10	1.12	1.14	1.17
2500	1.04	1.03	1.15	1.29	1.27	1.19	1.12	1.09	1.10	1.13	1.15	1.18
2600	1.06	1.01	1.13	1.27	1.24	1.16	1.11	1.09	1.10	1.13	1.17	1.20
2700	1.08	1.03	1.12	1.25	1.23	1.15	1.09	1.08	1.10	1.14	1.17	1.21
2800	1.10	1.06	1.11	1.23	1.21	1.13	1.07	1.07	1.10	1.14	1.18	1.22
2900	1.13	1.08	1.11	1.22	1.20	1.12	1.07	1.07	1.10	1.15	1.19	1.23
3000	1.14	1.10	1.12	1.22	1.20	1.12	1.06	1.06	1.09	1.14	1.18	1.22

Notes

- A. Performance and quality attributes and conditions not expressly stated in this specification document are intended to be excluded and do not form a part of this specification document.
- B. Electrical specifications and performance data contained in this specification document are based on Mini-Circuits' applicable established test performance criteria and measurement instructions.
- C. The parts covered by this specification document are subject to Mini-Circuits standard limited warranty and terms and conditions (collectively, "Standard Terms"); Purchasers of this part are entitled to the rights and benefits contained therein. For a full statement of the Standard Terms and the exclusive rights and remedies thereunder, please visit Mini-Circuits' website at www.minicircuits.com/MCLStore/terms.jsp



Programmable Attenuator

ZVVA-3000

Typical Performance Data @ +50°C

FREQUENCY (MHz)	Output VSWR (:1)											
	0.1 dB	1 dB	2.5 dB	5 dB	7.5 dB	10 dB	12.5 dB	15 dB	17.5 dB	20 dB	22.5 dB	25 dB
20	1.43	1.42	1.51	1.69	1.65	1.54	1.48	1.44	1.44	1.44	1.44	1.45
50	1.14	1.16	1.30	1.51	1.46	1.33	1.24	1.18	1.16	1.15	1.15	1.16
100	1.05	1.09	1.27	1.49	1.44	1.30	1.20	1.12	1.08	1.06	1.06	1.08
200	1.02	1.08	1.27	1.49	1.44	1.30	1.19	1.11	1.06	1.02	1.02	1.04
300	1.03	1.08	1.27	1.49	1.44	1.30	1.19	1.11	1.06	1.02	1.02	1.05
400	1.04	1.09	1.27	1.49	1.44	1.30	1.20	1.12	1.07	1.03	1.03	1.05
500	1.05	1.09	1.28	1.50	1.45	1.31	1.21	1.13	1.08	1.05	1.05	1.06
600	1.04	1.10	1.28	1.51	1.46	1.32	1.21	1.13	1.09	1.06	1.05	1.06
700	1.04	1.10	1.29	1.51	1.47	1.33	1.22	1.14	1.10	1.07	1.06	1.07
800	1.04	1.11	1.29	1.52	1.47	1.33	1.23	1.15	1.11	1.08	1.07	1.08
900	1.03	1.10	1.29	1.51	1.46	1.33	1.23	1.15	1.10	1.07	1.07	1.07
1000	1.01	1.10	1.29	1.51	1.47	1.34	1.23	1.15	1.10	1.07	1.06	1.06
1100	1.01	1.11	1.30	1.52	1.48	1.34	1.24	1.15	1.10	1.07	1.05	1.05
1200	1.02	1.11	1.30	1.52	1.48	1.35	1.24	1.15	1.10	1.06	1.04	1.04
1300	1.04	1.12	1.30	1.52	1.48	1.35	1.24	1.15	1.10	1.06	1.04	1.04
1400	1.06	1.12	1.29	1.51	1.47	1.34	1.23	1.15	1.10	1.05	1.02	1.03
1500	1.08	1.12	1.28	1.49	1.45	1.33	1.22	1.14	1.09	1.04	1.01	1.03
1600	1.09	1.13	1.27	1.47	1.43	1.31	1.21	1.13	1.08	1.03	1.01	1.04
1700	1.11	1.13	1.26	1.45	1.42	1.30	1.20	1.12	1.07	1.04	1.03	1.05
1800	1.12	1.13	1.25	1.43	1.40	1.28	1.19	1.11	1.07	1.05	1.06	1.08
1900	1.12	1.13	1.23	1.40	1.37	1.26	1.17	1.11	1.07	1.07	1.08	1.10
2000	1.12	1.12	1.21	1.38	1.35	1.24	1.16	1.10	1.08	1.09	1.10	1.13
2100	1.12	1.11	1.19	1.34	1.32	1.22	1.14	1.10	1.09	1.11	1.13	1.16
2200	1.12	1.09	1.16	1.31	1.29	1.20	1.13	1.10	1.10	1.13	1.15	1.18
2300	1.12	1.07	1.13	1.28	1.26	1.17	1.11	1.10	1.11	1.15	1.18	1.21
2400	1.12	1.06	1.11	1.25	1.23	1.15	1.10	1.10	1.13	1.17	1.20	1.24
2500	1.12	1.06	1.08	1.22	1.20	1.12	1.08	1.10	1.14	1.18	1.22	1.26
2600	1.13	1.06	1.06	1.20	1.18	1.10	1.07	1.10	1.15	1.20	1.24	1.28
2700	1.15	1.08	1.05	1.18	1.16	1.08	1.06	1.11	1.16	1.21	1.25	1.29
2800	1.17	1.10	1.05	1.16	1.14	1.06	1.05	1.11	1.17	1.23	1.27	1.32
2900	1.18	1.12	1.07	1.15	1.12	1.04	1.05	1.12	1.18	1.24	1.28	1.33
3000	1.20	1.14	1.09	1.15	1.12	1.04	1.04	1.12	1.18	1.24	1.28	1.33

Notes

- A. Performance and quality attributes and conditions not expressly stated in this specification document are intended to be excluded and do not form a part of this specification document.
- B. Electrical specifications and performance data contained in this specification document are based on Mini-Circuits' applicable established test performance criteria and measurement instructions.
- C. The parts covered by this specification document are subject to Mini-Circuits standard limited warranty and terms and conditions (collectively, "Standard Terms"); Purchasers of this part are entitled to the rights and benefits contained therein. For a full statement of the Standard Terms and the exclusive rights and remedies thereunder, please visit Mini-Circuits' website at www.minicircuits.com/MCLStore/terms.jsp



Programmable Attenuator

ZVVA-3000

Typical Performance Data @ +50°C

FREQUENCY (MHz)	IP3 (dBm)
20	50.32
50	53.06
100	52.67
250	52.64
500	52.63
750	52.72
1000	52.06
1250	52.04
1500	52.68
1750	52.57
2000	52.32
2250	52.46
2500	52.21
2750	52.27
3000	49.53

Notes

- A. Performance and quality attributes and conditions not expressly stated in this specification document are intended to be excluded and do not form a part of this specification document.
- B. Electrical specifications and performance data contained in this specification document are based on Mini-Circuits' applicable established test performance criteria and measurement instructions.
- C. The parts covered by this specification document are subject to Mini-Circuits standard limited warranty and terms and conditions (collectively, "Standard Terms"). Purchasers of this part are entitled to the rights and benefits contained therein. For a full statement of the Standard Terms and the exclusive rights and remedies thereunder, please visit Mini-Circuits' website at www.minicircuits.com/MCLStore/terms.jsp



Typical Performance Curves @ 0°C

Attenuation Accuracy vs. Frequency over Attenuation settings

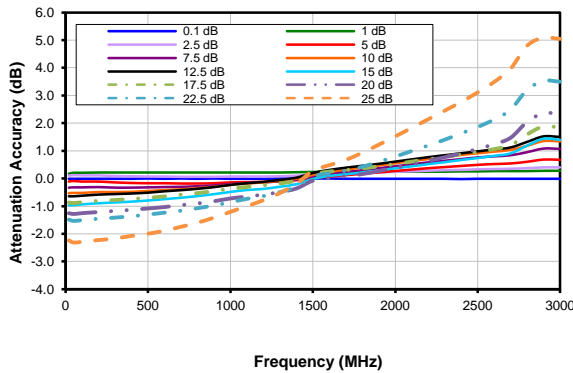

Attenuation relative to I.L. vs. Frequency over Attenuation settings

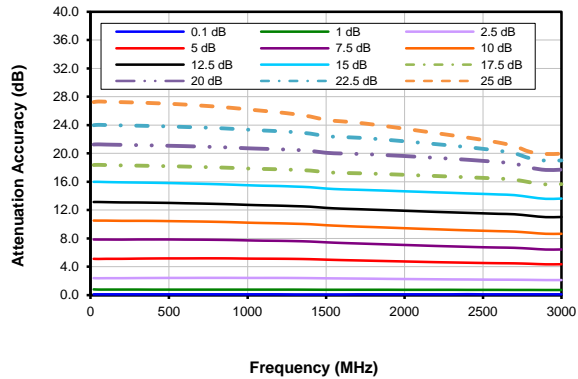

Input VSWR vs. Frequency over Attenuation settings

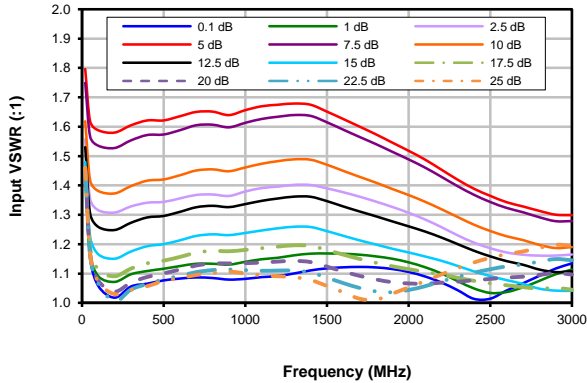

Output VSWR vs. Frequency over Attenuation settings

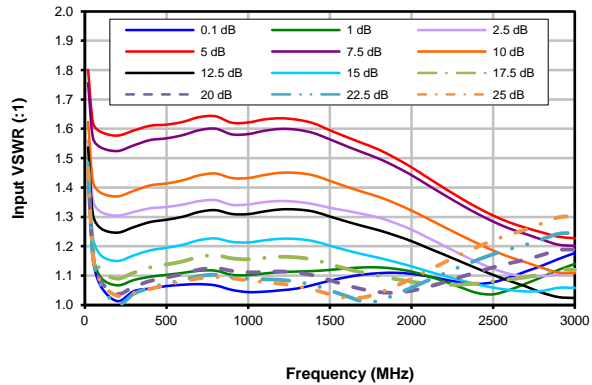

IP3 @ 0dB Attenuation

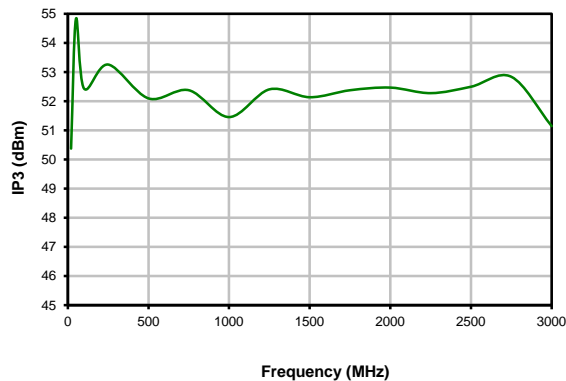

Notes

- A. Performance and quality attributes and conditions not expressly stated in this specification document are intended to be excluded and do not form a part of this specification document.
- B. Electrical specifications and performance data contained in this specification document are based on Mini-Circuits' applicable established test performance criteria and measurement instructions.
- C. The parts covered by this specification document are subject to Mini-Circuits' standard limited warranty and terms and conditions (collectively, "Standard Terms"); Purchasers of this part are entitled to the rights and benefits contained therein. For a full statement of the Standard Terms and the exclusive rights and remedies thereunder, please visit Mini-Circuits' website at www.minicircuits.com/MCLStore/terms.jsp



Programmable Attenuator

ZVVA-3000

Typical Performance Curves @ +25°C

Attenuation Accuracy vs. Frequency over Attenuation settings

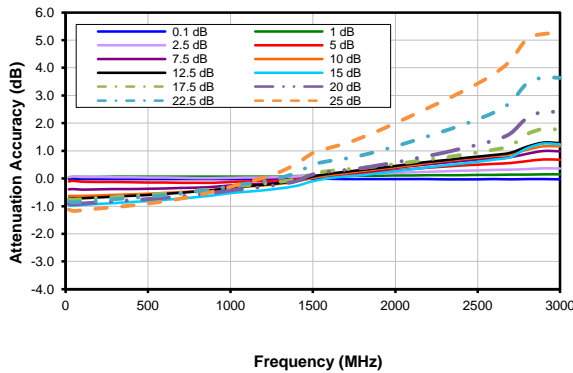

Attenuation relative to I.L. vs. Frequency over Attenuation settings

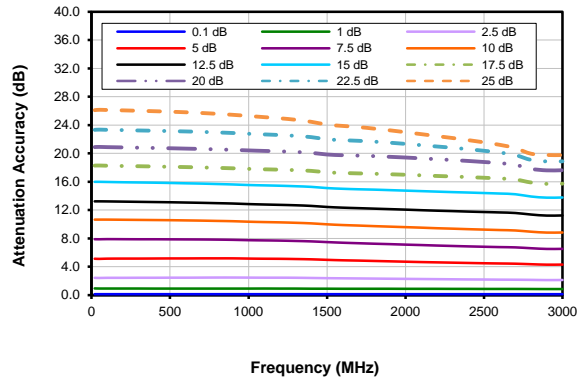

Input VSWR vs. Frequency over Attenuation settings

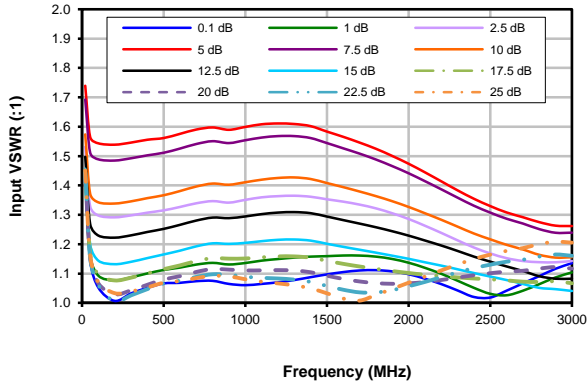

Output VSWR vs. Frequency over Attenuation settings

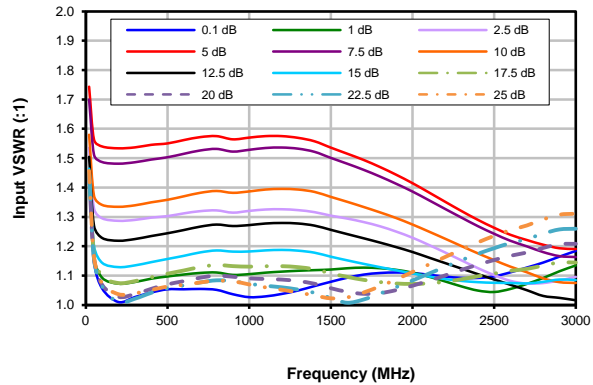

IP3 @ 0dB Attenuation

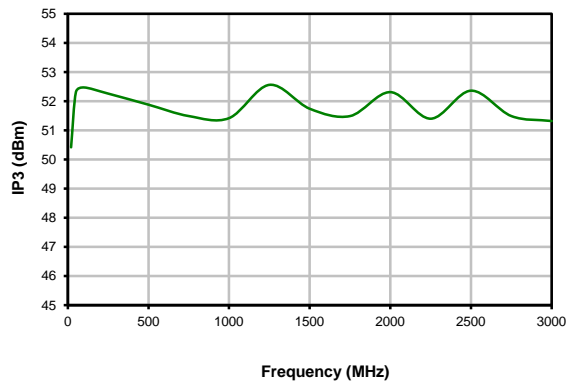

Notes

- A. Performance and quality attributes and conditions not expressly stated in this specification document are intended to be excluded and do not form a part of this specification document.
- B. Electrical specifications and performance data contained in this specification document are based on Mini-Circuits' applicable established test performance criteria and measurement instructions.
- C. The parts covered by this specification document are subject to Mini-Circuits' standard limited warranty and terms and conditions (collectively, "Standard Terms"); Purchasers of this part are entitled to the rights and benefits contained therein. For a full statement of the Standard Terms and the exclusive rights and remedies thereunder, please visit Mini-Circuits' website at www.minicircuits.com/MCLStore/terms.jsp



Programmable Attenuator

ZVVA-3000

Typical Performance Curves @ +50°C

Attenuation Accuracy vs. Frequency over Attenuation settings

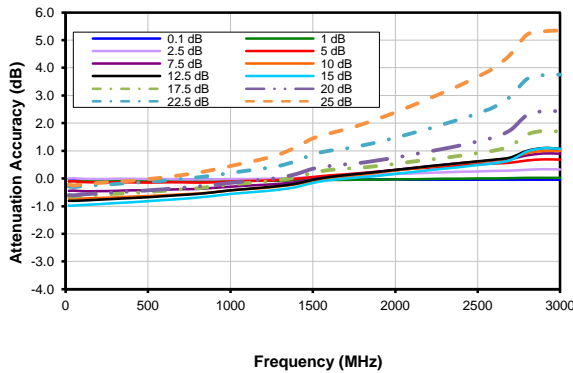

Attenuation relative to I.L. vs. Frequency over Attenuation settings

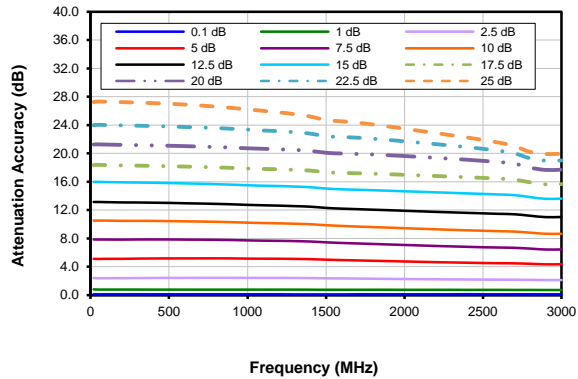

Input VSWR vs. Frequency over Attenuation settings

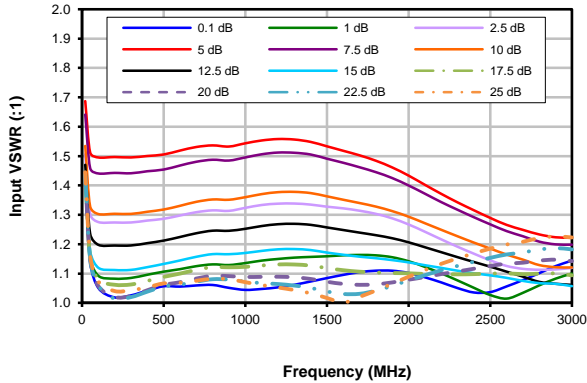

Output VSWR vs. Frequency over Attenuation settings

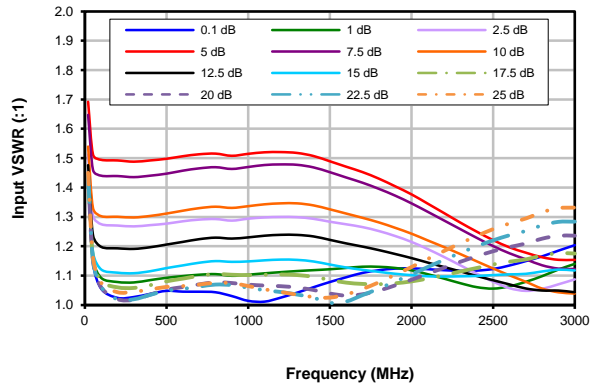

IP3 @ 0dB Attenuation

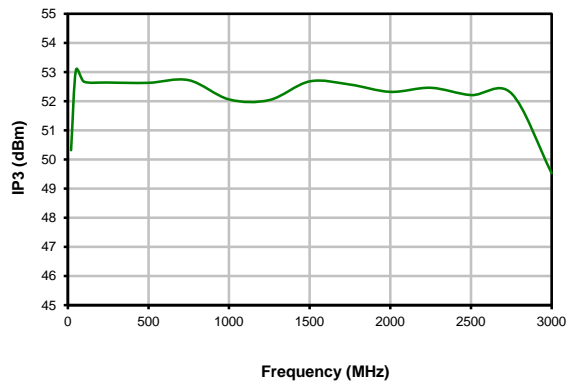

Notes

- A. Performance and quality attributes and conditions not expressly stated in this specification document are intended to be excluded and do not form a part of this specification document.
- B. Electrical specifications and performance data contained in this specification document are based on Mini-Circuits' applicable established test performance criteria and measurement instructions.
- C. The parts covered by this specification document are subject to Mini-Circuits' standard limited warranty and terms and conditions (collectively, "Standard Terms"); Purchasers of this part are entitled to the rights and benefits contained therein. For a full statement of the Standard Terms and the exclusive rights and remedies thereunder, please visit Mini-Circuits' website at www.minicircuits.com/MCLStore/terms.jsp



Case Style

QF

Outline Dimensions

QF2252

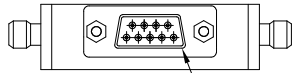

9 PIN D-SUB FEMALE

TOP VIEW

BRACKET OPTION

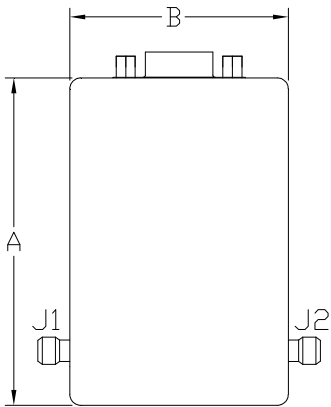

BOTTOM VIEW

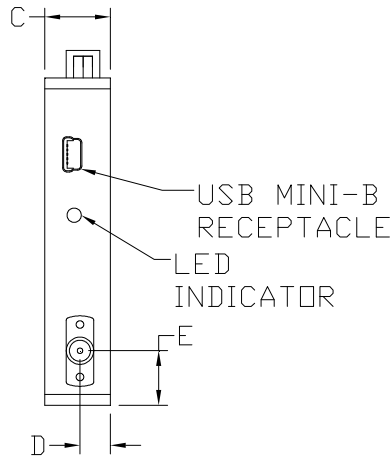

USB MINI-B RECEPTACLE
LED INDICATOR

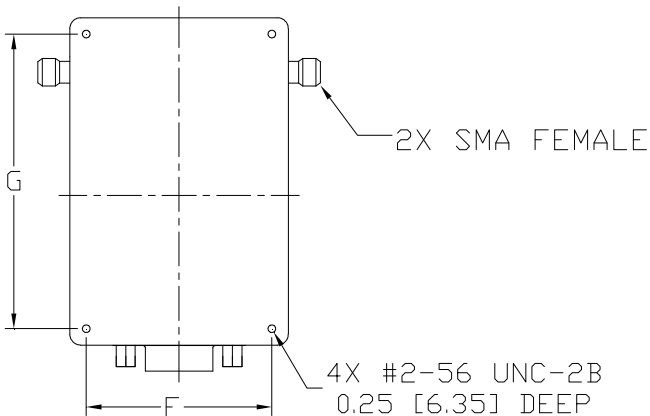
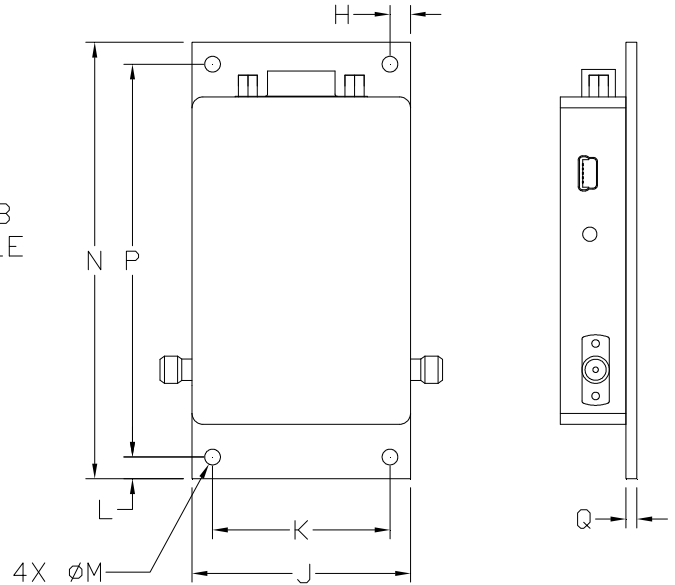

2X SMA FEMALE

4X #2-56 UNC-2B
0.25 [6.35] DEEP

Instruction for mounting bracket:

1. Tool required: Phillips head screwdriver
2. Mount the bracket over threaded holes on the bottom side with the fasteners provided with the bracket.

CASE#	A	B	C	D	E	F	G	H	J	K	L	M	N	P	Q	WT. GRAMS
QF2252	3.00 (76.2)	2.00 (50.8)	.60 (15.2)	.28 (7.1)	.50 (12.7)	1.700 (43.18)	2.700 (68.58)	.188 (4.76)	2.00 (50.8)	1.625 (41.28)	.200 (5.08)	.144 (3.66)	4.00 (101.6)	3.600 (91.44)	.100 (2.54)	130

Notes:

1. Case material: Nickel Plated Aluminum.



INTERNET <http://www.minicircuits.com>

P.O. Box 350166, Brooklyn, New York 11235-0003 (718) 934-4500 Fax (718) 332-4661

Distribution Centers NORTH AMERICA 800-654-7949 • 417-335-5935 • Fax 417-335-5945 • EUROPE 44-1252-832600 • Fax 44-1252-837010

Mini-Circuits ISO 9001 & ISO 14001 Certified



Environmental Specifications **ENV55T1**

All Mini-Circuits products are manufactured under exacting quality assurance and control standards, and are capable of meeting published specifications after being subjected to any or all of the following physical and environmental test.

Specification	Test/Inspection Condition	Reference/Spec
Operating Temperature	-0° to 50° C Ambient Environment	Individual Model Data Sheet
Storage Temperature	-20° to 85° C Ambient Environment	Individual Model Data Sheet
Operating and Storage Humidity	5% to 85% RH (non-condensing)	Ambient
Bench Handling Test	Bench Top Tip 45° & Drop	MIL-PRF-28800F
Transit Drop Test	Free Fall Drop, 20 cm (7.9 inches)	MIL-PRF-28800F Class 3