



MEDIUM POWER, HIGH GAIN

# Wideband Amplifier

## ZVE-453G+ ZVE-453GX+

50Ω 18 to 45 GHz Coaxial 3/4 W

### THE BIG DEAL

- High gain 41 dB typ. over the entire operating band
- Good gain flatness, ±3 dB typ.
- Saturated output power = +29 dBm typ. over 24 to 32 GHz
- Adjustable DC voltage, +10 to +15 V
- High Active Directivity (Isolation-Gain), 40 dB typ.



Generic photo used for illustration purposes only

### APPLICATIONS

- Wideband Test and Instrumentation
- 5G mmW
- SATCOM
- Wireless Infrastructure

Model No.	ZVE-453G+	ZVE-453GX+
Option	With heatsink & fan	Without heatsink & fan
Case Style	VN3071-4	
Connectors	2.4mm Female	

#### +RoHS Compliant

The +Suffix identifies RoHS Compliance.  
See our website for methodologies and qualifications

### PRODUCT OVERVIEW

Mini-Circuits' ZVE-453G+ is a coaxial, ½ Watt wideband high gain amplifier, operating from 18 to 45 GHz. This model operates over a single positive supply range of +10 to +15 V, allowing users to choose their desired operating voltage. Internal DC-DC conversion circuitry maintains constant efficiency over the full input voltage range. The amplifier incorporates several DC-protection features, such as over-voltage, reverse voltage and in-rush current, that protect the amplifier from damage if mishandled during operation. The wideband operation combined with high output power makes this amplifier an ideal choice for testing and instrumentation applications.

### KEY FEATURES

Feature	Advantages
Wide-band amplifier, 18 to 45 GHz	A single amplifier serves the need for applications including 5G bands (24 to 39 GHz), SATCOM, Test & Instrumentation, etc.
Integrated fan assembly	Model ZVE-453G+ utilizes two integrated fans, keeping the amplifier cool to the touch during normal operation at room temperature
High gain Low VSWR Medium RF power	Delivers rated power when connected to most lab signal generators enabling it to be used for many test applications.
Adjustable DC Supply Voltage	The device is capable of operating from +10 to +15 V with consistent DC power consumption
DC Protection – Over-voltage Reverse voltage In-rush Current	The internal DC circuitry allows the amplifier to be protected from external mishandling, that could lead to catastrophic failures in the field
High Active Directivity (Isolation-Gain), 40 dB typ.	High active directivity enables it to be easily integrated into high power amplifier chains minimizing interaction with adjacent circuitry.





MEDIUM POWER, HIGH GAIN

# Wideband Amplifier

## ZVE-453G+ ZVE-453GX+

50Ω 18 to 45 GHz Coaxial 3/4 W

### ELECTRICAL SPECIFICATIONS AT 25 °C BASEPLATE

Parameter	Condition (MHz)	ZVE-453G+ <sup>3</sup> ZVE-453GX+ <sup>4</sup>			Units
		Min.	Typ.	Max.	
Frequency Range		18000		45000	MHz
Gain	18000-30000	34.0	40		dB
	30000-45000	38.0	42		
Output Power at 1dB compression	18000 - 24000	+22.0	+26		dBm
	24000 - 36000	+26.5	+28.5		
	36000 - 45000	+23.0	+25.5		
Saturated Output Power <sup>7</sup>	18000 - 24000	+25.0	+27.5		dBm
	24000 - 36000	+27.0	+29.5		
	36000 - 45000	+24.5	+27.5		
Output IP3	18000 - 45000		38		dBm
Input VSWR	18000 - 45000		1.5	2.0	:1
Output VSWR <sup>1</sup>	18000 - 45000		1.5	2.0	:1
Operating DC Voltage (VDD)		+10	—	+15	V
Device Operating Current at +15 V (ZVE-453GX+ / ZVE-453G+)			530 <sup>4</sup> / 730 <sup>3</sup>	900 <sup>4</sup> / 1100 <sup>3</sup>	mA
Device Operating Power at +15 V			12 <sup>2</sup>	—	W

1. Open and short-circuit loads are not recommended at the amplifier output. Ensure proper 50 Ohm load before turning the amplifier "ON".
2. Device operating power is based on current when amplifier is in saturation.
3. For units with heatsink, limit ambient temperature to 50 °C.
4. For units without heatsink, limit the maximum baseplate temperature to 60 °C.

### MAXIMUM RATINGS<sup>6</sup>

Parameter	Ratings
Operating Temperature	ZVE-453G+ -40 °C to +50 °C Ambient ZVE-453GX+ -40 °C to +60 °C Baseplate
Storage Temperature	-40 °C to +85 °C
Total Power Dissipation	13.5 W
RF Input Power <sup>5</sup> (CW)	+2 dBm
DC Operating Voltage	+16 V

5. Specified under matched load to 50 ohms.
6. Continuous operation is not recommended at these extremes. Permanent damage may occur if any of these limits are exceeded.
7. At Psat, Pout changes less than 0.1 dB for a 1 dB change in Pin





MEDIUM POWER, HIGH GAIN

# Wideband Amplifier

## ZVE-453G+ ZVE-453GX+

50Ω 18 to 45 GHz Coaxial 3/4 W

### OUTLINE DRAWING FOR MODELS WITH HEATSINK & FAN (ZVE-453G+)

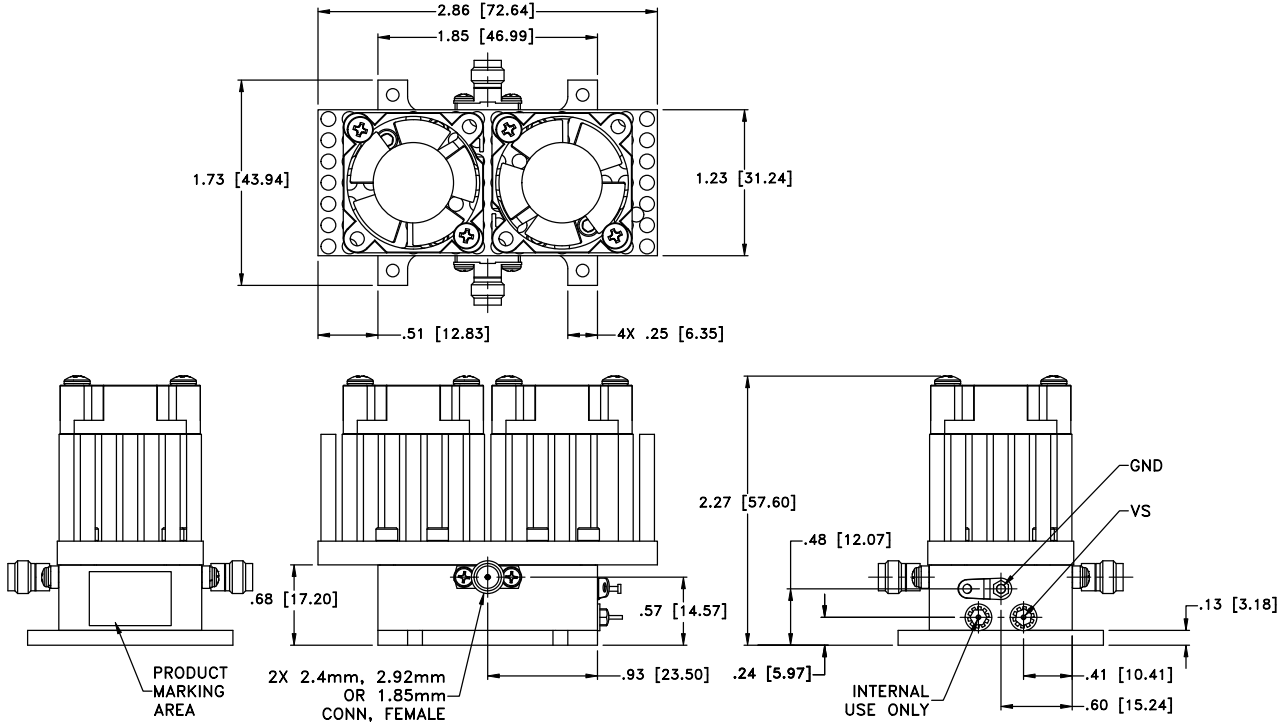

### MOUNTING INFORMATION FOR MODELS WITHOUT HEATSINK & FAN (ZVE-453GX+)

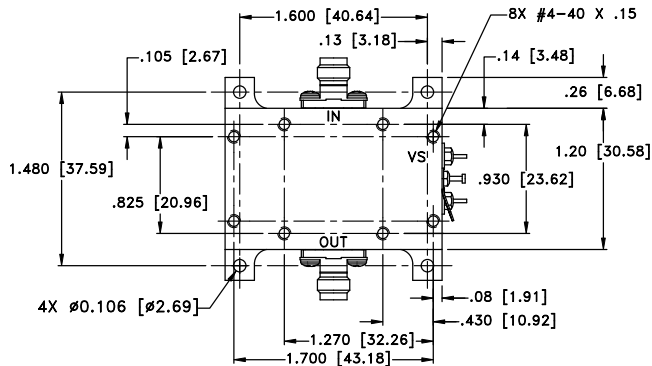

Weight: 160 grams; Without Heatsink: 60 grams

WT. GRAMS 160 grams; WITHOUT HEATSINK GRAMS 60 grams  
Dimensions are in inches [mm]. Tolerances: 2 Pl. ±.03; 3 Pl. ±.015



MEDIUM POWER, HIGH GAIN

# Wideband Amplifier

## ZVE-453G+ ZVE-453GX+

50Ω 18 to 45 GHz Coaxial 3/4 W

### TYPICAL PERFORMANCE DATA/CURVES

Frequency (MHz)	Gain (dB)	Active Directivity (dB)	VSWR (:1)		Pout @ 1 dB Compression (dBm)	Pout @ Saturation (dBm)	Output IP3 (dBm)
			IN	OUT			
18000	37.53	52.70	1.64	1.27	23.72	26.59	34.24
21000	40.90	42.65	1.03	1.19	26.86	28.20	37.32
24000	42.36	37.70	1.06	1.56	27.98	28.63	38.29
27000	39.98	35.71	1.51	1.43	29.16	30.32	41.08
30000	41.40	40.45	1.30	1.20	29.38	30.34	39.30
33000	40.82	45.79	1.08	1.36	29.04	29.98	41.13
36000	41.63	41.93	1.41	1.23	28.19	28.95	43.81
39000	42.35	41.26	1.13	1.37	26.83	27.94	37.68
42000	43.23	38.23	1.21	1.51	25.60	27.29	38.39
45000	41.81	37.42	1.06	1.66	24.97	26.62	37.04

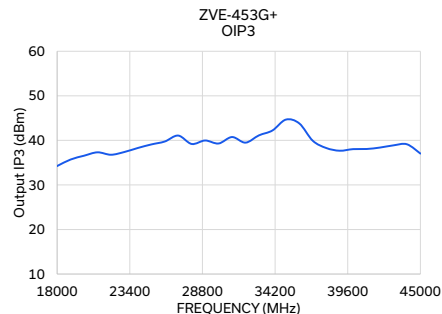
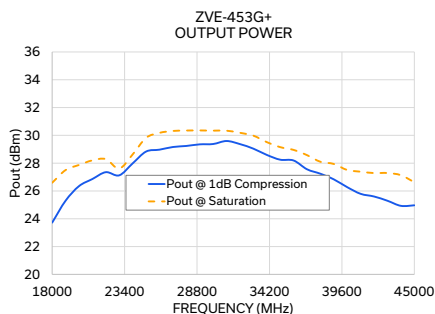
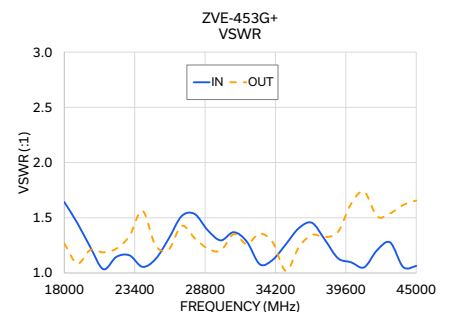
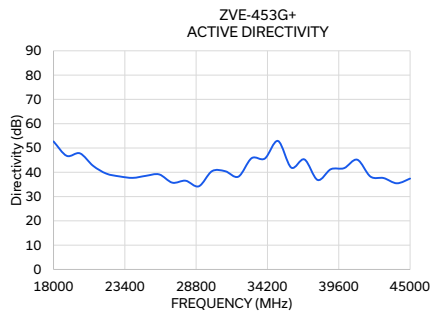
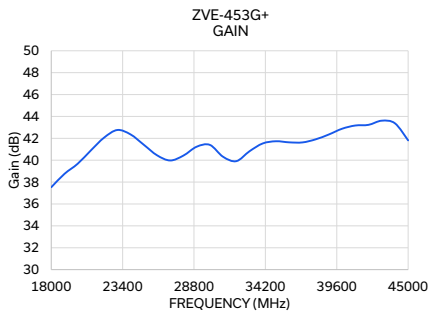

- NOTES**
- A. Performance and quality attributes and conditions not expressly stated in this specification document are intended to be excluded and do not form a part of this specification document.
  - B. Electrical specifications and performance data contained in this specification document are based on Mini-Circuit's applicable established test performance criteria and measurement instructions.
  - C. The parts covered by this specification document are subject to Mini-Circuits standard limited warranty and terms and conditions (collectively, "Standard Terms"); Purchasers of this part are entitled to the rights and benefits contained therein. For a full statement of the standard. Terms and the exclusive rights and remedies thereunder, please visit Mini-Circuits' website at [www.minicircuits.com/MCLStore/terms.jsp](http://www.minicircuits.com/MCLStore/terms.jsp)



# Wideband Amplifier

# ZVE-453G+

## Typical Performance Data

FREQ. (MHz)	GAIN (dB) 15V	DIRECTIVITY (dB) 15V	VSWR (:1)		Pout @ 1 dB COMPRESSION (dBm) 15V	Pout @ SATURATION (dBm) 15V	OUTUPUT IP3 (dBm) 15V
			IN 15V	OUT 15V			
18000	37.53	52.70	1.64	1.27	23.72	26.59	34.24
19000	38.75	46.77	1.45	1.08	25.30	27.50	35.70
20000	39.68	47.79	1.23	1.21	26.35	27.87	36.56
21000	40.90	42.65	1.03	1.19	26.86	28.20	37.32
22000	42.07	39.45	1.15	1.22	27.35	28.29	36.78
23000	42.76	38.30	1.16	1.34	27.12	27.62	37.40
24000	42.36	37.70	1.06	1.56	27.98	28.63	38.29
25000	41.41	38.54	1.13	1.25	28.83	29.82	39.09
26000	40.45	39.12	1.31	1.21	28.97	30.18	39.75
27000	39.98	35.71	1.51	1.43	29.16	30.32	41.08
28000	40.42	36.53	1.53	1.32	29.24	30.35	39.19
29000	41.23	34.23	1.39	1.22	29.35	30.35	39.98
30000	41.40	40.45	1.30	1.20	29.38	30.34	39.30
31000	40.31	40.43	1.37	1.35	29.59	30.34	40.75
32000	39.91	38.20	1.28	1.26	29.37	30.18	39.49
33000	40.82	45.79	1.08	1.36	29.04	29.98	41.13
34000	41.53	45.64	1.12	1.28	28.59	29.51	42.22
35000	41.73	52.89	1.26	1.02	28.25	29.15	44.66
36000	41.63	41.93	1.41	1.23	28.19	28.95	43.81
37000	41.62	45.28	1.45	1.34	27.56	28.58	39.92
38000	41.90	36.83	1.30	1.33	27.24	28.10	38.29
39000	42.35	41.26	1.13	1.37	26.83	27.94	37.68
40000	42.87	41.69	1.10	1.63	26.27	27.51	38.04
41000	43.17	45.17	1.05	1.74	25.79	27.39	38.07
42000	43.23	38.23	1.21	1.51	25.60	27.29	38.39
43000	43.61	37.61	1.28	1.54	25.29	27.29	38.89
44000	43.37	35.46	1.05	1.62	24.93	27.13	39.13
45000	41.81	37.42	1.06	1.66	24.97	26.62	37.04

## Typical Performance Curves

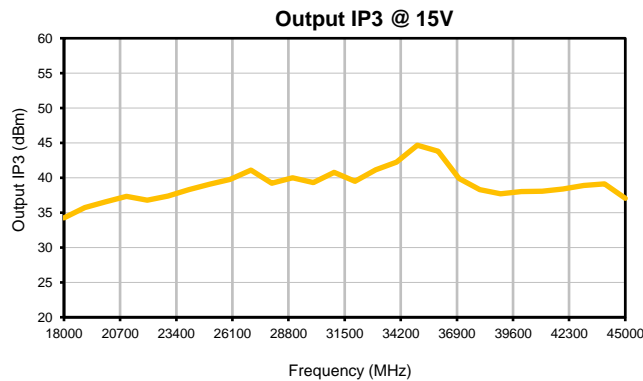
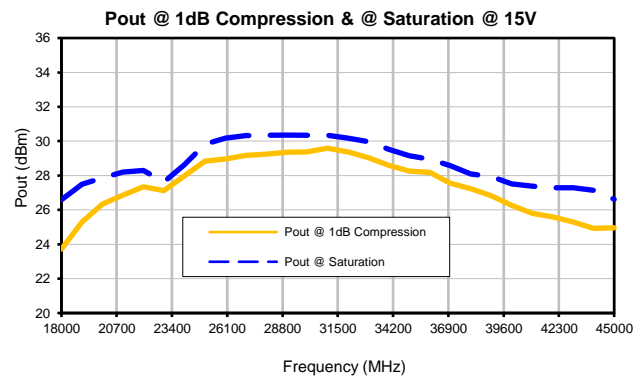
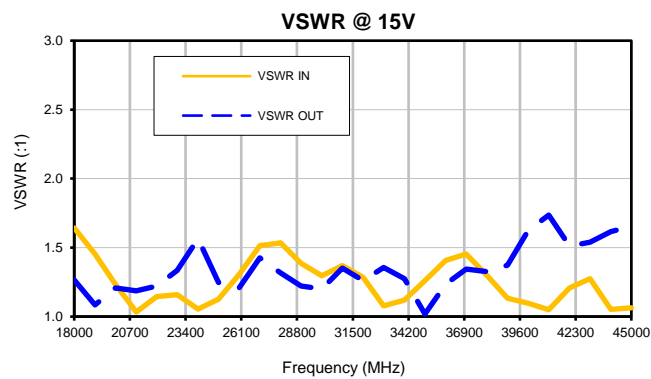
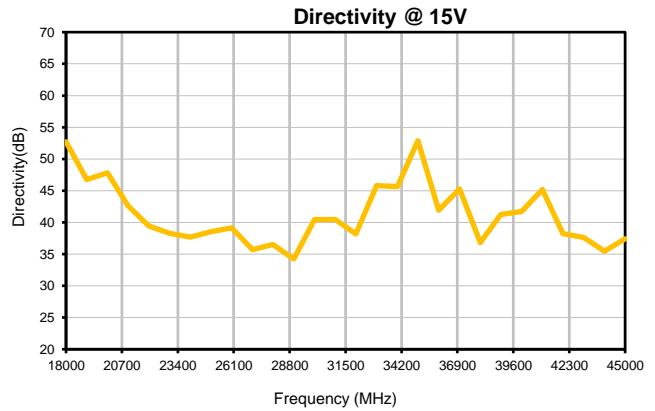
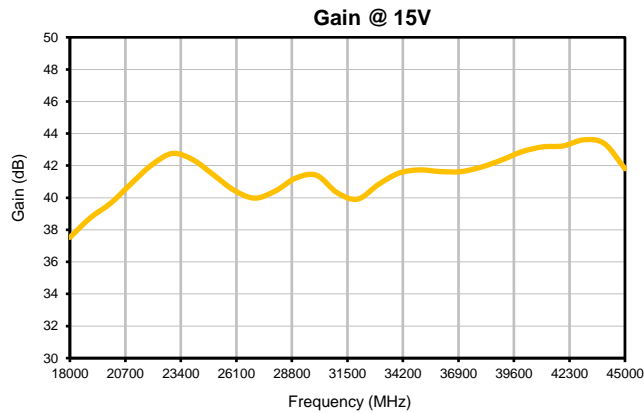

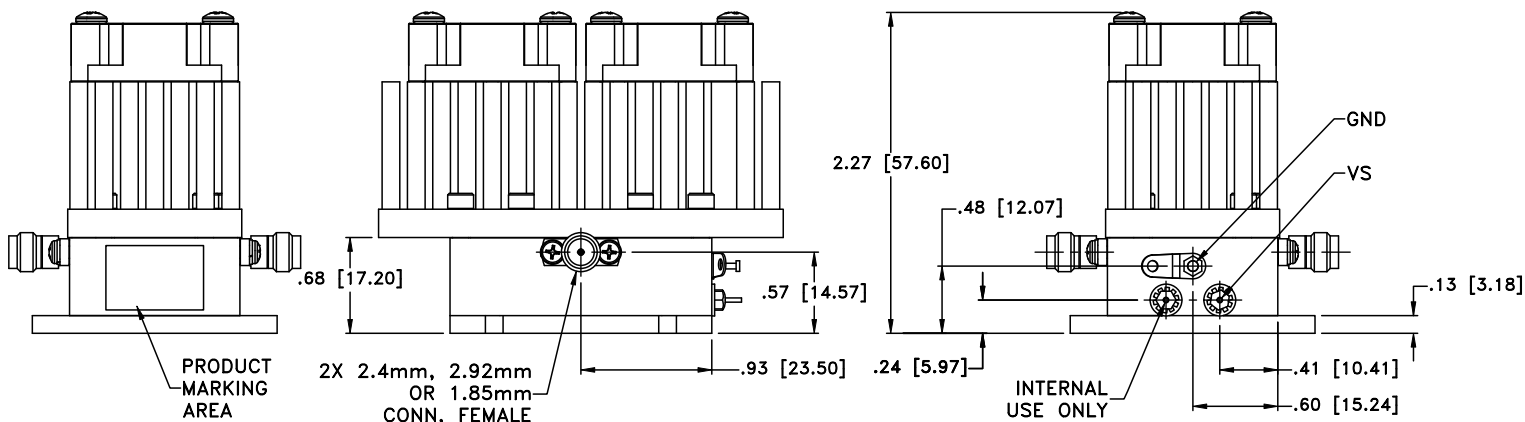
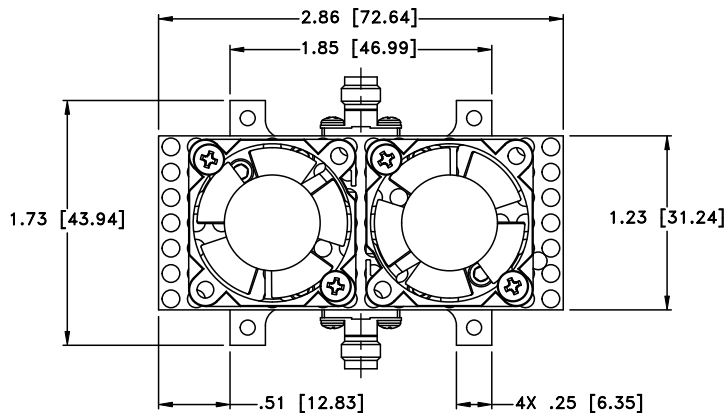

OQWPVKP I'KPHQTOCVKQP'QH'OQFGN'YIVJQWV'JGCVUKPM

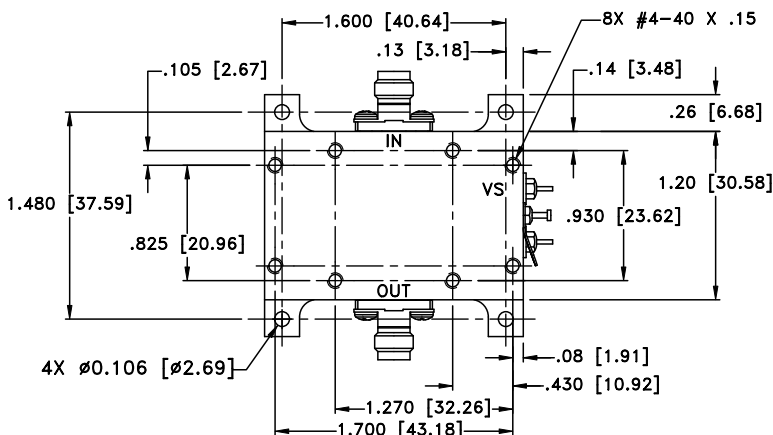

Y V0 Y V0I TCO U'382'i tco u=""Y KJ QWV'J GCVUKPMI TCO U'82'i tco u"

Flo gpukqpu'ctg'lp'pej gu"o o #0Vqrgtcegu<4'Rr0025="5'Rr000237"

Pqvgu<

30 Ecug'o cvgtkn<Cno kpwo 0

40 Ecug'hpokj <I qif 'r rvpki =

50 J gcvukpmihokj <""Drcen'cpqf k g0

60 Tghgt'vq'v'g'lpf kxf wcnb qf gnf'cvc'uj gg'vht'v'g'v'r g'qh'epppgevqtu'cxckrdrg0

70 Uj cr g'qh'epppgevqt'hrpi g'o c' 'xct{0



P.O. Box 350166, Brooklyn, New York 11235-0003 (718) 934-4500 Fax (718) 332-4661 For detailed performance specs & shopping online see Mini-Circuits web site

The Design Engineers Search Engine Provides ACTUAL Data Instantly From MINI-CIRCUITS At: [www.minicircuits.com](http://www.minicircuits.com)



RF/IF MICROWAVE COMPONENTS

All Mini-Circuits products are manufactured under exacting quality assurance and control standards, and are capable of meeting published specifications after being subjected to any or all of the following physical and environmental test.

<b>Specification</b>	<b>Test/Inspection Condition</b>	<b>Reference/Spec</b>
Operating Temperature	-40° to +60° C Baseplate Temp	Individual Model Data Sheet
Storage Temperature	-40° to +85° C Ambient Environment	Individual Model Data Sheet
Burn-in	(DC on) 72 hours at 25°C	----
Thermal Shock	-40° C to +85°C, 100 cycles	Transition time = 5 mins, Dwell time = 30 mins
Vibration	Random Vibration (non-operating)	MIL-STD-883K, Method 2025, Cond. 1A