



CAVITY COAXIAL

Bandpass Filter

ZVBP-4R3G-S+

50Ω 4200 to 4400 MHz SMA Female

KEY FEATURES

- Low Insertion Loss, 0.6 dB Typ.
- Good Return Loss, 19 dB Typ.
- High Rejection, 93 dB Typ.
- Stopband up to 8 GHz
- Power Handling 15 Watts

APPLICATIONS

- Aerospace
- 5G Mitigation

PRODUCT OVERVIEW

Mini-Circuits' ZVBP-4R3G-S+ is a coaxial cavity filter designed by implementing resonant structures with very high Q and are ideal for narrow-band, high-selectivity applications. Mini-Circuits' coaxial cavity filters feature a special protective assembly to prevent accidental de-tuning that would otherwise require expensive replacement or return to factory for re-tuning. Precise machining allows realization of cavity filters with small form factors for applications where size is critical.



Generic photo used for illustration purposes only

FUNCTIONAL DIAGRAM

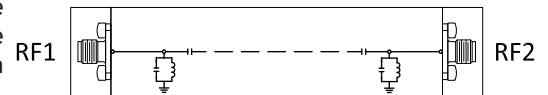

ELECTRICAL SPECIFICATIONS¹ AT +25°C

| Parameter | F# | Frequency (MHz) | Min. | Typ. | Max. | Units |
|------------------|----------------|-----------------|------|------|------|-------|
| Center Frequency | — | — | — | 4300 | — | MHz |
| Passband | Insertion Loss | F1-F2 | — | 0.6 | 0.9 | dB |
| | Return Loss | F1-F2 | 15 | 19 | — | dB |
| Stop Band, Lower | Rejection | DC-F3 | 75 | 85 | — | dB |
| | | F3-F4 | 55 | 60 | — | dB |
| Stop Band, Upper | Rejection | F5-F6 | 58 | 65 | — | dB |
| | | F6-F7 | 75 | 93 | — | dB |

1. This filter is bi-directional RF1 and RF2 ports may be interchanged, see S-Parameters for actual performance.

ABSOLUTE MAXIMUM RATINGS^{2,3}

| Parameter | Ratings |
|--------------------------|--------------------|
| Operating Temperature | -40°C to +85°C |
| Storage Temperature | -55°C to +100°C |
| Input Power ⁴ | 15 W max. at +25°C |

2. Permanent damage may occur if any of these limits are exceeded.
3. Input and output ports are DC short to ground.
4. Power rating applies only to signals within the passband.

TYPICAL FREQUENCY RESPONSE AT +25°C

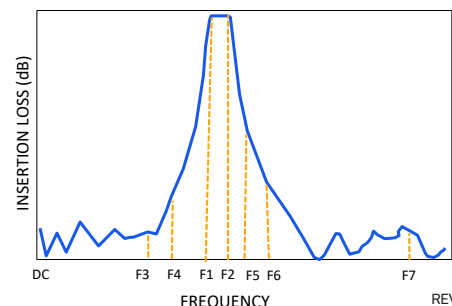

REV. OR
ECO-026012
ZVBP-4R3G-S+
EDU4973
URJ
250626





CAVITY COAXIAL

Bandpass Filter

ZVBP-4R3G-S+

Mini-Circuits

50Ω

4200 to 4400 MHz SMA Female

TYPICAL PERFORMANCE GRAPHS

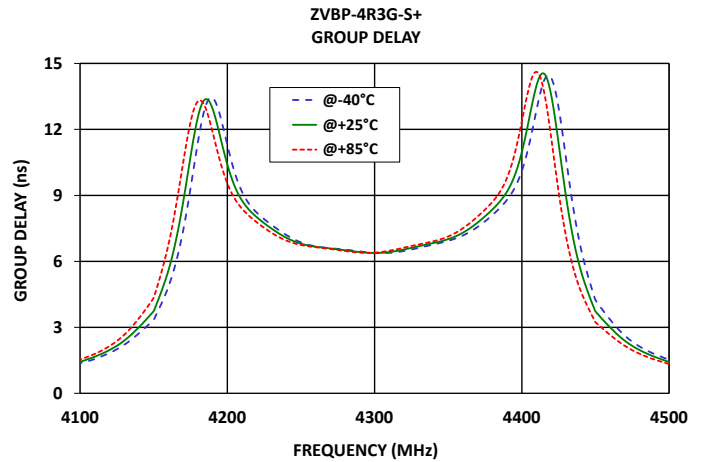
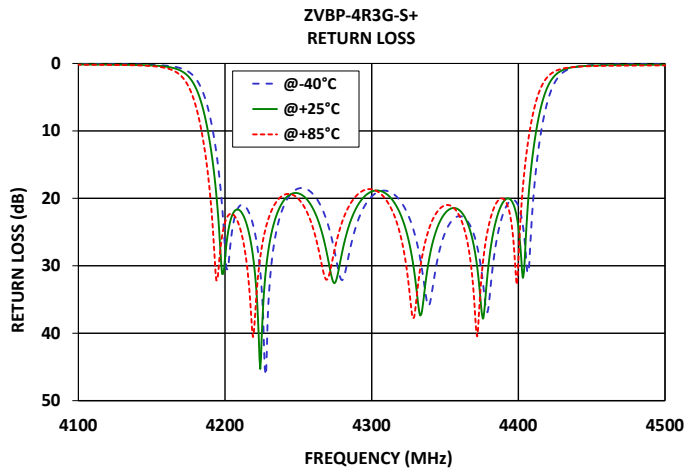
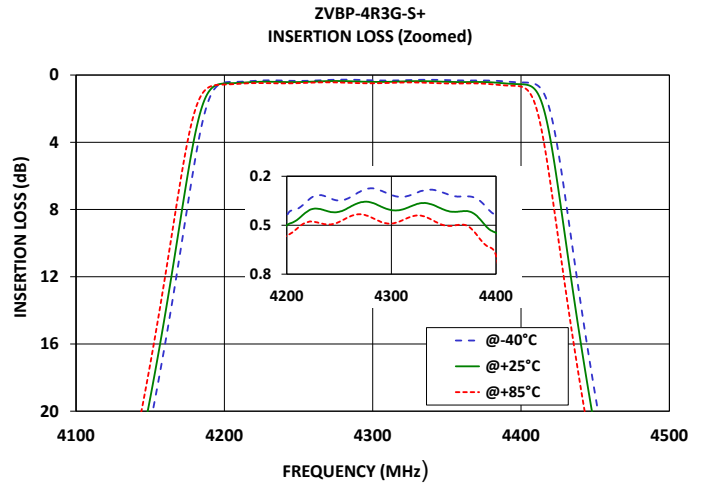
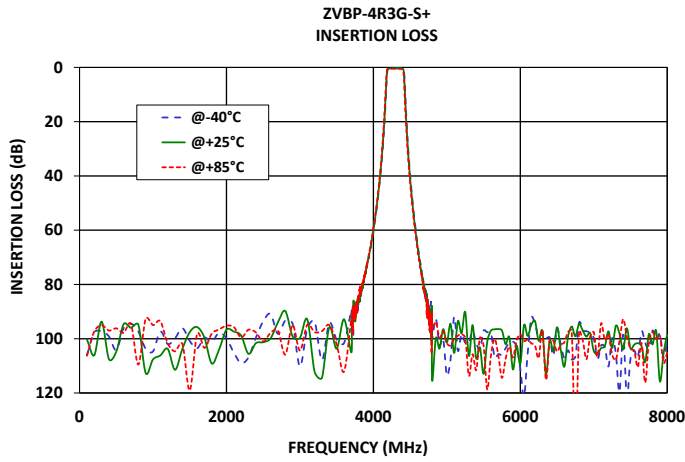



CAVITY COAXIAL

Bandpass Filter

ZVBP-4R3G-S+

50Ω 4200 to 4400 MHz SMA Female

CONNECTOR DESCRIPTION

| Function | Marking on Unit | Connector |
|------------------|-----------------|------------|
| RF1 ¹ | 1 | SMA Female |
| RF2 ¹ | 2 | SMA Female |

CASE STYLE DRAWING

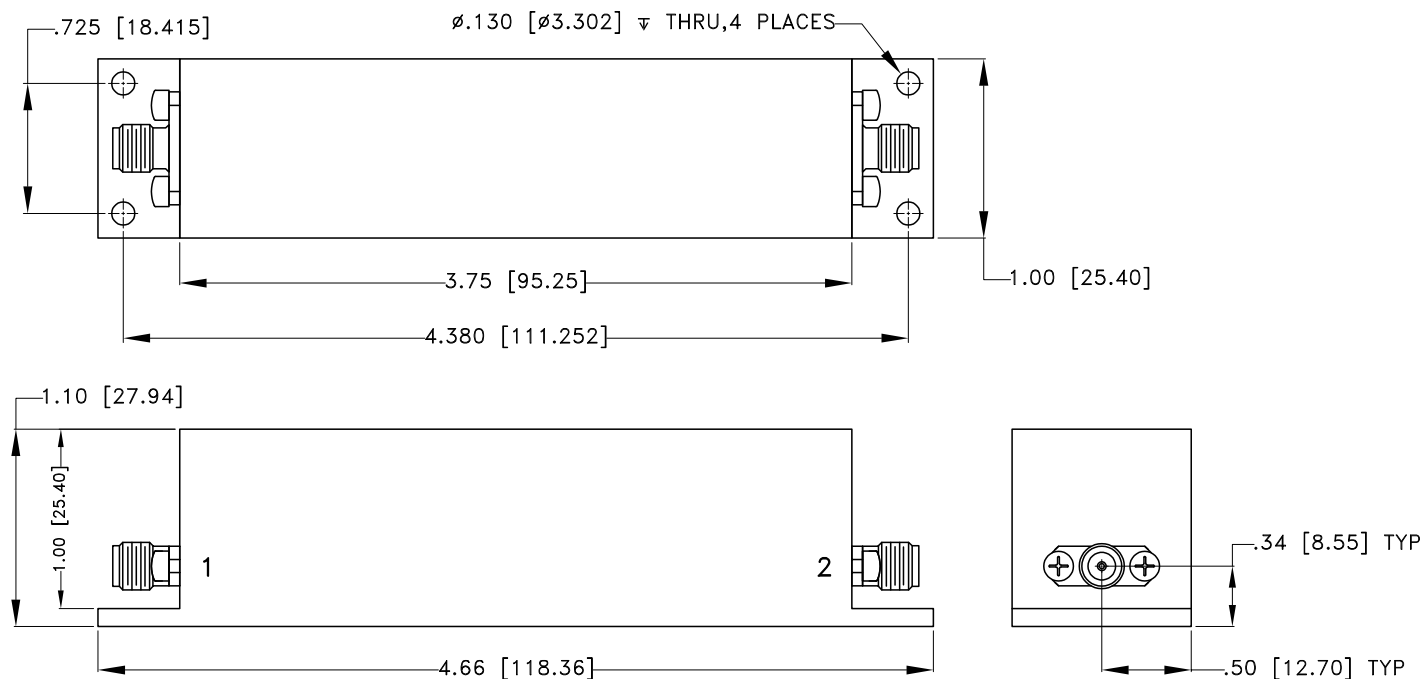

Unit weight : 135 grams

Dimensions are in inches (mm).Tolerances: 2 Pl. + .06 [1.52]; 3 Pl. + .015 [.38]

PRODUCT MARKING*: ZVBP-4R3G-S+

*Marking may contain other features or characters for internal lot control.



CAVITY COAXIAL

Bandpass Filter

ZVBP-4R3G-S+

Mini-Circuits

50Ω

4200 to 4400 MHz SMA Female

ADDITIONAL INFORMATION IS AVAILABLE ON OUR DASHBOARD

[CLICK HERE](#)

| | |
|---------------------------|---|
| Performance Data & Graphs | <p>Data</p> <p>Graphs</p> <p>S-Parameter (S2P Files) Data Set (.zip file)</p> |
| Case Style | BAP3677 |
| RoHS Status | Compliant |
| Environmental Ratings | ENV46 |

NOTES

- A. Performance and quality attributes and conditions not expressly stated in this specification document are intended to be excluded and do not form a part of this specification document.
- B. Electrical specifications and performance data contained in this specification document are based on Mini-Circuits' applicable established test performance criteria and measurement instructions.
- C. The parts covered by this specification document are subject to Mini-Circuits' standard limited warranty and terms and conditions (collectively, "Standard Terms"); Purchasers of this part are entitled to the rights and benefits contained therein. For a full statement of the standard terms and the exclusive rights and remedies thereunder, please visit Mini-Circuits' website at www.minicircuits.com/terms/viewterm.html



Typical Performance Data

| FREQ. (MHz) | INSERTION LOSS | | | INPUT RETURN LOSS | | | OUTPUT RETURN LOSS | | |
|--------------------|----------------|--------|--------|-------------------|--------|--------|--------------------|--------|--------|
| | (dB) | | | (dB) | | | (dB) | | |
| | @-40°C | @+25°C | @+85°C | @-40°C | @+25°C | @+85°C | @-40°C | @+25°C | @+85°C |
| 100 | 106.07 | 100.22 | 106.30 | 0.02 | 0.02 | 0.03 | 0.02 | 0.02 | 0.03 |
| 200 | 97.66 | 106.12 | 97.34 | 0.03 | 0.04 | 0.05 | 0.04 | 0.04 | 0.05 |
| 300 | 97.31 | 93.71 | 95.01 | 0.04 | 0.05 | 0.06 | 0.04 | 0.05 | 0.06 |
| 500 | 104.17 | 104.77 | 96.18 | 0.04 | 0.06 | 0.07 | 0.05 | 0.06 | 0.07 |
| 1000 | 104.68 | 107.62 | 94.99 | 0.03 | 0.06 | 0.08 | 0.02 | 0.05 | 0.07 |
| 1200 | 101.95 | 103.73 | 101.73 | 0.03 | 0.06 | 0.09 | 0.01 | 0.04 | 0.06 |
| 1500 | 100.83 | 97.57 | 119.04 | 0.01 | 0.06 | 0.09 | 0.00 | 0.03 | 0.06 |
| 1600 | 103.52 | 95.71 | 98.33 | 0.01 | 0.06 | 0.09 | 0.01 | 0.03 | 0.06 |
| 2000 | 99.87 | 96.68 | 95.22 | 0.00 | 0.06 | 0.10 | 0.01 | 0.04 | 0.08 |
| 2200 | 109.02 | 98.86 | 99.56 | 0.00 | 0.06 | 0.11 | 0.01 | 0.04 | 0.08 |
| 2400 | 99.65 | 101.64 | 97.67 | 0.00 | 0.07 | 0.12 | 0.01 | 0.04 | 0.09 |
| 2600 | 90.89 | 99.88 | 97.84 | 0.01 | 0.07 | 0.13 | 0.01 | 0.04 | 0.10 |
| 2800 | 93.36 | 89.78 | 105.88 | 0.01 | 0.08 | 0.14 | 0.01 | 0.05 | 0.10 |
| 3000 | 110.22 | 99.68 | 104.40 | 0.02 | 0.08 | 0.15 | 0.00 | 0.05 | 0.11 |
| 3800 | 84.23 | 84.34 | 84.32 | 0.04 | 0.11 | 0.17 | 0.02 | 0.08 | 0.13 |
| 4000 | 60.46 | 59.92 | 59.19 | 0.06 | 0.12 | 0.17 | 0.04 | 0.09 | 0.14 |
| 4100 | 38.49 | 37.53 | 36.30 | 0.10 | 0.15 | 0.19 | 0.07 | 0.12 | 0.16 |
| 4126 | 30.26 | 29.05 | 27.51 | 0.12 | 0.18 | 0.22 | 0.09 | 0.15 | 0.20 |
| 4151 | 20.31 | 18.75 | 16.70 | 0.22 | 0.31 | 0.41 | 0.19 | 0.27 | 0.38 |
| 4184 | 3.28 | 2.15 | 1.27 | 3.77 | 5.96 | 10.07 | 3.80 | 5.99 | 10.15 |
| 4200 | 0.45 | 0.50 | 0.56 | 27.50 | 28.84 | 23.57 | 31.87 | 30.47 | 23.64 |
| 4210 | 0.40 | 0.47 | 0.52 | 21.11 | 21.79 | 24.27 | 20.90 | 21.58 | 24.11 |
| 4220 | 0.35 | 0.41 | 0.48 | 24.74 | 30.28 | 38.90 | 24.27 | 29.50 | 37.59 |
| 4240 | 0.33 | 0.42 | 0.50 | 21.17 | 20.34 | 19.51 | 21.32 | 20.41 | 19.58 |
| 4260 | 0.33 | 0.39 | 0.45 | 19.37 | 21.54 | 24.41 | 19.34 | 21.59 | 24.77 |
| 4280 | 0.27 | 0.36 | 0.45 | 32.11 | 27.84 | 23.41 | 34.99 | 29.19 | 23.93 |
| 4300 | 0.31 | 0.41 | 0.49 | 19.72 | 18.99 | 18.65 | 19.89 | 19.11 | 18.81 |
| 4320 | 0.31 | 0.38 | 0.45 | 20.53 | 22.56 | 25.83 | 20.49 | 22.51 | 26.00 |
| 4350 | 0.30 | 0.40 | 0.50 | 25.13 | 22.22 | 21.04 | 25.02 | 22.16 | 20.92 |
| 4370 | 0.32 | 0.41 | 0.50 | 25.58 | 27.44 | 35.44 | 26.03 | 27.99 | 36.54 |
| 4380 | 0.33 | 0.43 | 0.55 | 35.44 | 29.22 | 23.84 | 38.92 | 29.19 | 23.40 |
| 4390 | 0.38 | 0.50 | 0.62 | 22.05 | 20.45 | 20.11 | 21.84 | 20.13 | 19.46 |
| 4400 | 0.44 | 0.55 | 0.69 | 21.14 | 24.23 | 29.38 | 20.46 | 22.38 | 23.65 |
| 4500 | 39.53 | 40.96 | 42.60 | 0.10 | 0.19 | 0.29 | 0.07 | 0.15 | 0.24 |
| 4600 | 64.91 | 65.56 | 66.96 | 0.07 | 0.16 | 0.25 | 0.04 | 0.12 | 0.20 |
| 4700 | 81.73 | 83.37 | 83.83 | 0.06 | 0.15 | 0.23 | 0.04 | 0.11 | 0.18 |
| 4800 | 100.11 | 115.40 | 96.78 | 0.06 | 0.14 | 0.22 | 0.04 | 0.11 | 0.18 |
| 4900 | 102.42 | 103.64 | 99.61 | 0.06 | 0.14 | 0.21 | 0.04 | 0.11 | 0.17 |
| 5000 | 113.54 | 101.41 | 101.65 | 0.06 | 0.14 | 0.21 | 0.04 | 0.11 | 0.17 |
| 5100 | 91.97 | 105.25 | 100.05 | 0.06 | 0.14 | 0.20 | 0.04 | 0.10 | 0.16 |
| 5200 | 98.27 | 97.98 | 98.31 | 0.06 | 0.14 | 0.20 | 0.03 | 0.10 | 0.16 |
| 5300 | 101.47 | 106.38 | 113.66 | 0.07 | 0.14 | 0.20 | 0.04 | 0.10 | 0.16 |
| 5400 | 101.52 | 107.28 | 111.58 | 0.06 | 0.13 | 0.19 | 0.04 | 0.10 | 0.16 |
| 5500 | 97.00 | 112.99 | 102.49 | 0.06 | 0.13 | 0.19 | 0.03 | 0.10 | 0.15 |
| 5600 | 97.72 | 97.02 | 106.20 | 0.07 | 0.13 | 0.19 | 0.03 | 0.09 | 0.15 |
| 5700 | 105.66 | 96.46 | 106.05 | 0.07 | 0.13 | 0.18 | 0.03 | 0.09 | 0.14 |
| 5800 | 103.52 | 102.01 | 107.41 | 0.06 | 0.13 | 0.18 | 0.03 | 0.09 | 0.14 |
| 5900 | 101.09 | 111.35 | 106.90 | 0.06 | 0.12 | 0.17 | 0.02 | 0.09 | 0.13 |
| 6000 | 111.05 | 109.36 | 98.36 | 0.06 | 0.12 | 0.16 | 0.02 | 0.08 | 0.13 |
| 6100 | 105.47 | 98.99 | 100.41 | 0.05 | 0.12 | 0.16 | 0.02 | 0.08 | 0.12 |
| 6200 | 94.49 | 93.49 | 102.53 | 0.05 | 0.11 | 0.15 | 0.02 | 0.08 | 0.12 |
| 6400 | 99.53 | 100.62 | 100.40 | 0.05 | 0.11 | 0.14 | 0.01 | 0.07 | 0.11 |
| 6600 | 107.12 | 110.27 | 101.34 | 0.04 | 0.10 | 0.14 | 0.00 | 0.06 | 0.09 |
| 6800 | 94.10 | 94.54 | 97.36 | 0.04 | 0.10 | 0.13 | 0.01 | 0.05 | 0.08 |
| 7000 | 99.87 | 104.59 | 97.62 | 0.03 | 0.09 | 0.11 | 0.02 | 0.04 | 0.07 |
| 7200 | 110.21 | 97.26 | 98.40 | 0.01 | 0.07 | 0.10 | 0.03 | 0.03 | 0.07 |
| 7400 | 98.49 | 104.01 | 92.79 | 0.00 | 0.07 | 0.09 | 0.04 | 0.02 | 0.05 |
| 7600 | 106.95 | 101.63 | 110.47 | 0.01 | 0.06 | 0.09 | 0.05 | 0.01 | 0.05 |
| 7800 | 96.99 | 102.12 | 97.57 | 0.02 | 0.05 | 0.08 | 0.06 | 0.00 | 0.04 |
| 8000 | 101.32 | 98.86 | 105.14 | 0.03 | 0.05 | 0.08 | 0.07 | 0.00 | 0.03 |

Typical Performance Data

| FREQ. (MHz) | GROUP DELAY | | |
|--------------------|-------------|--------|--------|
| | (nsec) | | |
| | @-40°C | @+25°C | @+85°C |
| 4200 | 11.30 | 10.41 | 9.55 |
| 4210 | 9.16 | 8.76 | 8.39 |
| 4215 | 8.60 | 8.33 | 8.06 |
| 4220 | 8.21 | 8.01 | 7.78 |
| 4225 | 7.92 | 7.74 | 7.53 |
| 4230 | 7.66 | 7.49 | 7.30 |
| 4235 | 7.42 | 7.27 | 7.11 |
| 4240 | 7.20 | 7.08 | 6.95 |
| 4245 | 7.01 | 6.92 | 6.83 |
| 4250 | 6.86 | 6.80 | 6.75 |
| 4255 | 6.75 | 6.72 | 6.69 |
| 4260 | 6.68 | 6.66 | 6.64 |
| 4265 | 6.63 | 6.62 | 6.60 |
| 4270 | 6.60 | 6.59 | 6.56 |
| 4275 | 6.57 | 6.55 | 6.52 |
| 4280 | 6.53 | 6.51 | 6.47 |
| 4285 | 6.49 | 6.46 | 6.43 |
| 4290 | 6.45 | 6.42 | 6.40 |
| 4300 | 6.38 | 6.38 | 6.40 |
| 4305 | 6.37 | 6.39 | 6.43 |
| 4310 | 6.39 | 6.42 | 6.48 |
| 4315 | 6.42 | 6.47 | 6.55 |
| 4320 | 6.47 | 6.54 | 6.62 |
| 4325 | 6.54 | 6.61 | 6.70 |
| 4330 | 6.61 | 6.69 | 6.77 |
| 4335 | 6.69 | 6.76 | 6.84 |
| 4340 | 6.77 | 6.83 | 6.91 |
| 4345 | 6.85 | 6.91 | 7.01 |
| 4350 | 6.93 | 7.01 | 7.13 |
| 4355 | 7.04 | 7.14 | 7.29 |
| 4360 | 7.18 | 7.31 | 7.50 |
| 4365 | 7.35 | 7.51 | 7.76 |
| 4370 | 7.57 | 7.77 | 8.04 |
| 4375 | 7.82 | 8.05 | 8.35 |
| 4380 | 8.10 | 8.36 | 8.70 |
| 4385 | 8.42 | 8.71 | 9.15 |
| 4390 | 8.80 | 9.18 | 9.81 |
| 4395 | 9.32 | 9.88 | 10.86 |
| 4400 | 10.11 | 10.97 | 12.37 |

Typical Performance Curves

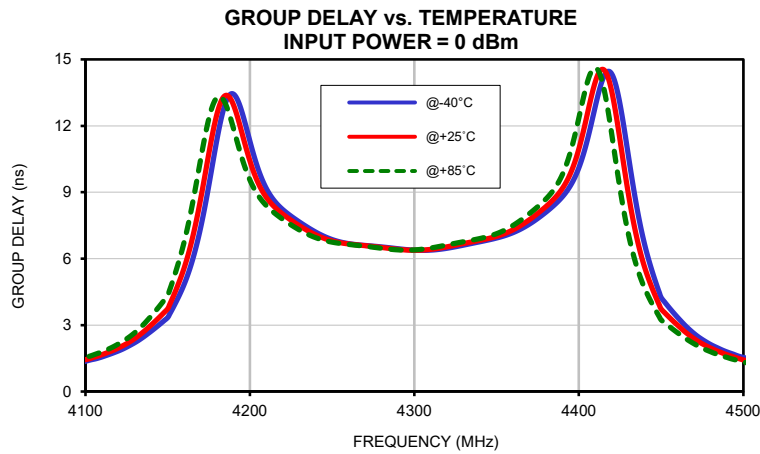
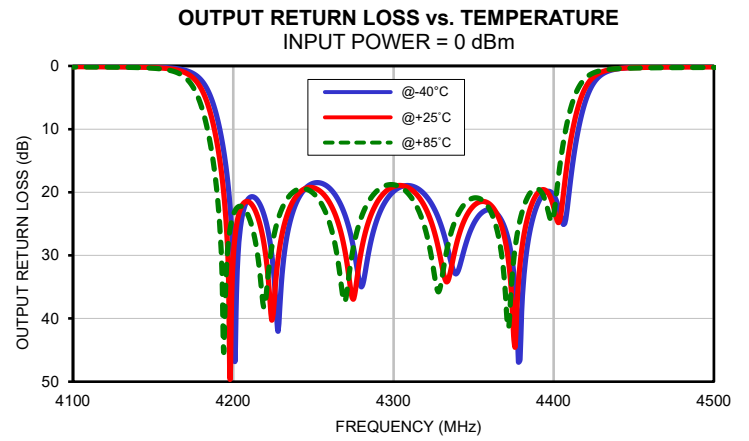
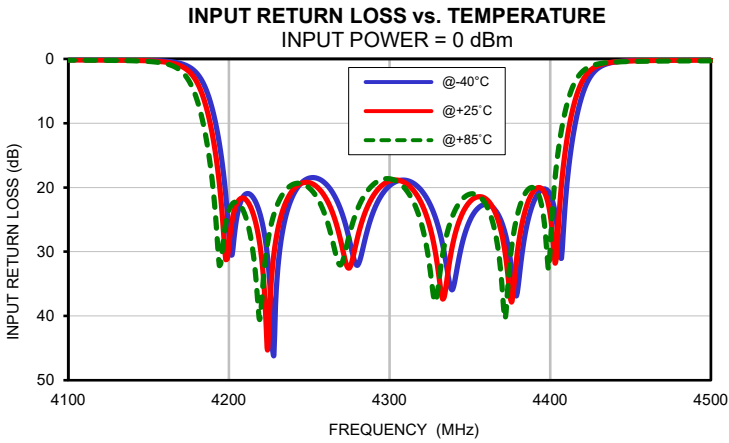
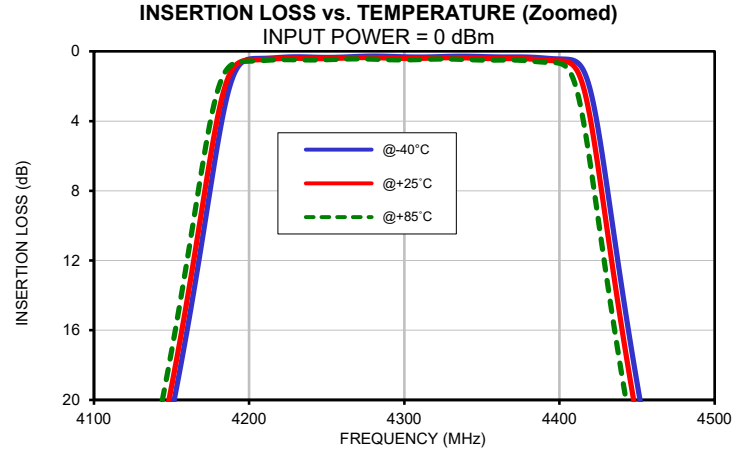
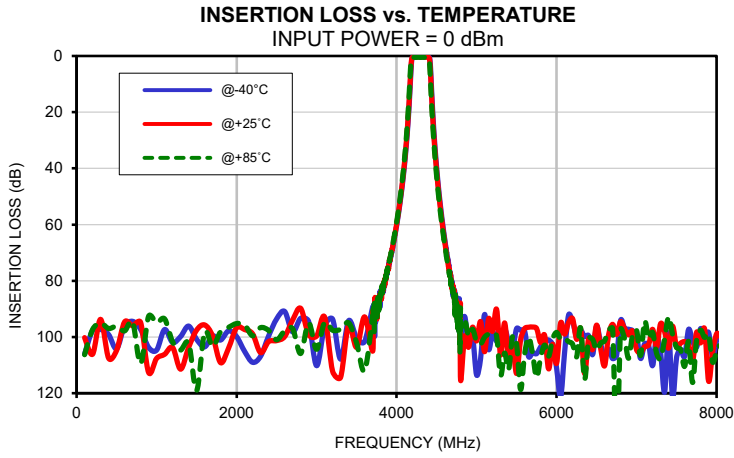

Outline Dimensions

BAP3677

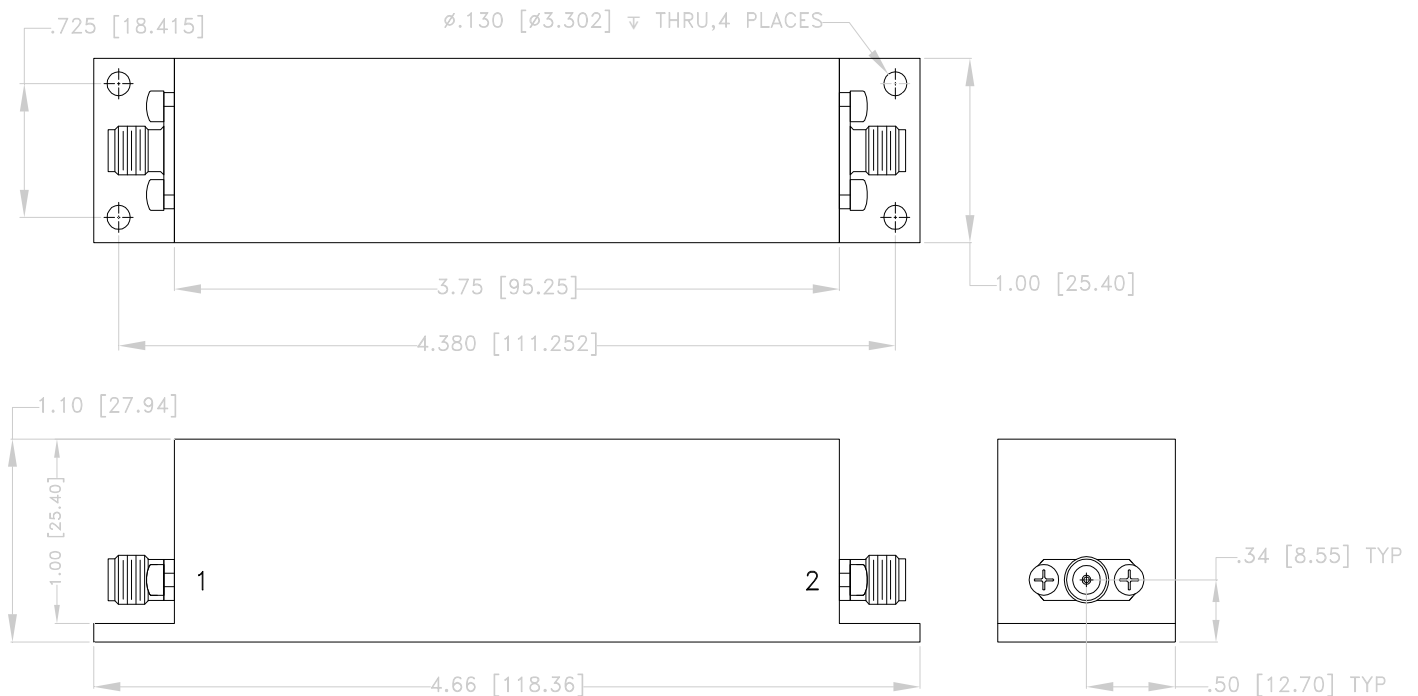

Dimensions are in inches [mm]. Tolerances: 2 Pl. $\pm .06$ [1.52]; 3 Pl. $\pm .015$ [.38]

Notes:

1. Case Material: Aluminum.
2. Case Finish: Powder coated.
3. Unit Weight: 135 Grams.
4. Refer to the individual model data sheet for the type of connectors available.

Mini-Circuits®
ISO 9001 ISO 14001 CERTIFIED

ALL NEW
minicircuits.com

P.O. Box 350166, Brooklyn, New York 11235-0003 (718) 934-4500 Fax (718) 332-4661 For detailed performance specs & shopping online see Mini-Circuits web site



The Design Engineers Search Engine Provides ACTUAL Data Instantly From MINI-CIRCUITS At: www.minicircuits.com

RF/IF MICROWAVE COMPONENTS

All Mini-Circuits products are manufactured under exacting quality assurance and control standards, and are capable of meeting published specifications after being subjected to any or all of the following physical and environmental test.

| Specification | Test/Inspection Condition | Reference/Spec |
|----------------------------|---|---|
| Operating Temperature | -55° to 100°C Ambient Environment | Individual Model Data Sheet |
| Storage Temperature | -55° to 100° C Ambient Environment | Individual Model Data Sheet |
| Humidity | 90 to 95% RH, 40°C, 96 hours; Units may require bake-out after humidity to restore full performance. | MIL-STD-202, Method 103, Condition B |
| Thermal Shock | -55° to 100°C, 100 cycles | MIL-STD-202, Method 107, Condition A-3, except +100°C |
| Vibration (High Frequency) | 20g peak, 10-2000 Hz, 12 times in each of three perpendicular directions (total 36) | MIL-STD-202, Method 204, Condition D |
| Mechanical Shock | 50g, 11ms half-sine, 3 shocks each direction 3 axes (total 18) | MIL-STD-202, Method 213, Condition A |