

Cavity Bandpass Filters

50Ω DC to 40 GHz

The Big Deal

- Very low insertion loss with excellent power handling
- Very fast roll-off with wide stopband
- Passbands up to 36 GHz
- Stopbands up to 40 GHz



Product Overview

Mini-Circuits' cavity filters are designed by implementing resonant structures with very high Q and are ideal for narrow-band, high-selectivity applications. These designs can provide bandwidths as narrow as 1% with very high selectivity and excellent low noise floor. Low insertion loss combined with excellent power handling makes them well-suited for transmitter and receiver front end. Advanced filter design and construction enables stopband width greater than 3x the center frequency.

Mini-Circuits' cavity filters feature a special protective assembly to prevent accidental de-tuning that would otherwise require expensive replacement or return to factory for re-tuning. Custom integrated assembly with LNA and bias tees results in greatly simplifying system integration. Precise machining allows realization of cavity filters with small form factors for applications where size is critical. Excellent repeatability across units is achieved through precise tuning and process control.

Key Features

Feature	Advantages
Low insertion loss	Low signal loss results in better SNR in receiver front end and better power delivery to antenna in transmitter
Fast roll-off	Higher selectivity results in better adjacent channel rejection and dynamic range
Wide stopband	Wide spur free band results in better receiver sensitivity
High power handling	Well suited for transmitter application
Protective assembly	Prevents accidental de-tuning of precisely tuned resonant circuit

Notes

- Performance and quality attributes and conditions not expressly stated in this specification document are intended to be excluded and do not form a part of this specification document.
- Electrical specifications and performance data contained in this specification document are based on Mini-Circuit's applicable established test performance criteria and measurement instructions.
- The parts covered by this specification document are subject to Mini-Circuits standard limited warranty and terms and conditions (collectively, "Standard Terms"); Purchasers of this part are entitled to the rights and benefits contained therein. For a full statement of the Standard Terms and the exclusive rights and remedies thereunder, please visit Mini-Circuits' website at www.minicircuits.com/MCLStore/terms.jsp



Bandpass Filter

50Ω 11200 to 11400 MHz

ZVBP-11G3-S+



Generic photo used for illustration purposes only

CASE STYLE: PU2164

Connectors Model
SMA-F ZVBP-11G3-S+

Features

- Low insertion loss, 2 dB typical
- Broad Stopband performance up to 20GHz
- Fast roll-off
- Connectorized package
- Small size

Applications

- Satellite
- Radar

Electrical Specifications at 25°C

Parameter	F#	Frequency (MHz)	Min.	Typ.	Max.	Unit	
Pass Band	Center Frequency	-	-	11300	-	MHz	
	Insertion Loss	F1-F2	11200-11400	-	2	3	dB
	VSWR	F1-F2	11200-11400	-	1.4	1.5	:1
Stop Band, Lower	Insertion Loss	DC-F3	DC - 11030	40	48	-	dB
	VSWR	DC-F3	DC - 11030	-	40	-	:1
Stop Band, Upper	Insertion Loss	F4-F5	11580-20000	40	48	-	dB
	VSWR	F4-F5	11580-20000	-	7	-	:1

Maximum Ratings

Operating Temperature	-40°C to 85°C
Storage Temperature	-55°C to 100°C
RF Power Input	10 W max.

Permanent damage may occur if any of these limits are exceeded.

Functional Schematic

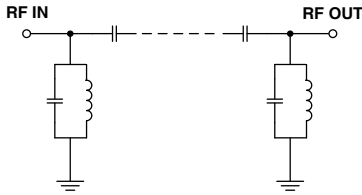

Typical Frequency Response

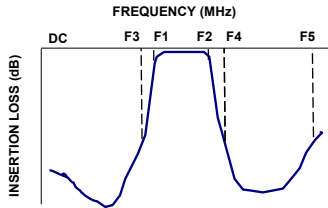

Typical Performance Data at 25°C

Frequency (MHz)	Insertion Loss (dB)	VSWR (:1)	Frequency (MHz)	Group Delay (nsec)
10	68.19	1737.18	11200	9.04
500	96.68	289.53	11210	8.42
3000	104.04	868.59	11220	7.72
7050	103.71	66.82	11230	7.14
9500	101.21	75.53	11240	6.74
11030	53.60	289.53	11250	6.46
11115	30.18	75.53	11260	6.26
11140	19.96	31.03	11270	6.12
11175	3.44	1.94	11280	6.01
11180	2.55	1.34	11290	5.94
11200	1.74	1.34	11300	5.90
11300	1.35	1.31	11310	5.89
11400	1.77	1.22	11320	5.91
11420	2.39	1.33	11330	5.95
11430	3.21	1.55	11340	6.03
11470	20.55	18.30	11350	6.16
11495	30.33	28.96	11360	6.34
11580	52.74	56.04	11380	6.92
16000	100.46	1737.18	11390	7.42
20000	72.31	217.15	11400	8.05

+RoHS Compliant

The +Suffix identifies RoHS Compliance. See our web site for RoHS Compliance methodologies and qualifications

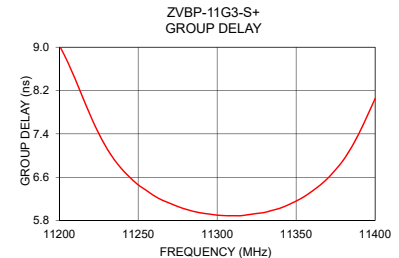
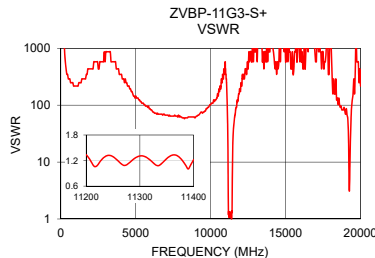
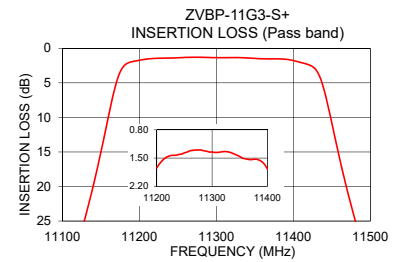
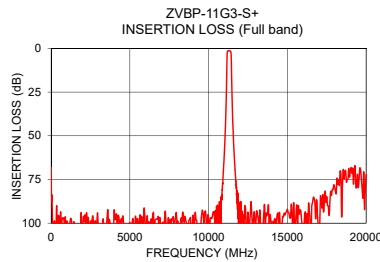

Notes

- Performance and quality attributes and conditions not expressly stated in this specification document are intended to be excluded and do not form a part of this specification document.
- Electrical specifications and performance data contained in this specification document are based on Mini-Circuits' applicable established test performance criteria and measurement instructions.
- The parts covered by this specification document are subject to Mini-Circuits standard limited warranty and terms and conditions (collectively, "Standard Terms"); Purchasers of this part are entitled to the rights and benefits contained therein. For a full statement of the Standard Terms and the exclusive rights and remedies thereunder, please visit Mini-Circuits' website at www.minicircuits.com/MCLStore/terms.jsp



Coaxial Connections

PORT - 1	SMA-FEMALE
PORT - 2	SMA-FEMALE

Outline Drawing

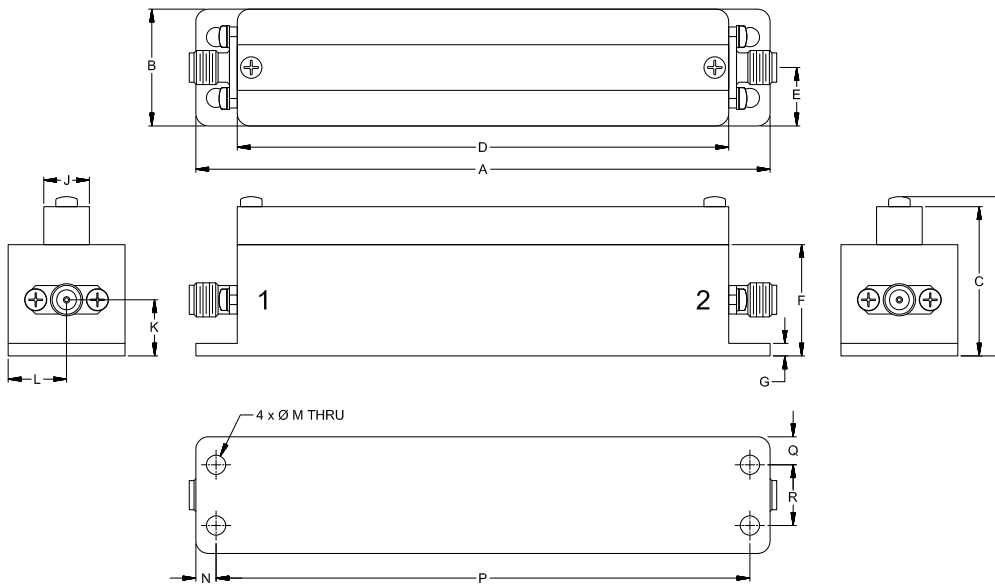

Outline Dimensions ($\frac{\text{inch}}{\text{mm}}$)

A	B	C	D	E	F	G	H	J
4.47	.91	1.16	3.82	.45	.87	.10	1.24	.36
113.43	23.06	29.50	97.07	11.53	22.00	2.50	31.48	9.02
K	L	M	N	P	Q	R	Wt.	
.44	.45	.150	.16	4.151	.22	.472	grams	
11.10	11.53	3.81	4.00	105.43	5.53	12.00	113	

Note: Please refer to case style drawing for details.

Notes

- A. Performance and quality attributes and conditions not expressly stated in this specification document are intended to be excluded and do not form a part of this specification document.
- B. Electrical specifications and performance data contained in this specification document are based on Mini-Circuit's applicable established test performance criteria and measurement instructions.
- C. The parts covered by this specification document are subject to Mini-Circuits standard limited warranty and terms and conditions (collectively, "Standard Terms"); Purchasers of this part are entitled to the rights and benefits contained therein. For a full statement of the Standard Terms and the exclusive rights and remedies thereunder, please visit Mini-Circuits' website at www.minicircuits.com/MCLStore/terms.jsp



Coaxial Band Pass Filter

ZVBP-11G3-S+

Typical Performance Data

FREQ. (MHz)	INSERTION LOSS			INPUT RETURN LOSS			OUTPUT RETURN LOSS		
	(dB)			(dB)			(dB)		
	@-40°C	@+25°C	@+85°C	@-40°C	@+25°C	@+85°C	@-40°C	@+25°C	@+85°C
10	72.73	68.19	65.29	0.01	0.01	0.01	0.01	0.00	0.01
350	97.62	89.98	105.05	0.04	0.04	0.04	0.04	0.05	0.06
2850	105.03	105.28	99.84	0.05	0.03	0.08	0.04	0.04	0.11
4700	98.61	113.30	100.61	0.01	0.10	0.17	0.00	0.10	0.18
5300	107.51	120.90	99.59	0.07	0.15	0.21	0.05	0.14	0.21
5900	94.51	91.53	95.55	0.12	0.20	0.25	0.10	0.19	0.23
7600	94.41	105.44	118.63	0.16	0.26	0.29	0.13	0.25	0.29
9050	90.44	100.13	104.40	0.12	0.27	0.33	0.08	0.23	0.30
9650	100.87	94.90	90.66	0.04	0.22	0.29	0.03	0.20	0.30
10740	90.87	93.53	87.96	0.16	0.07	0.21	0.12	0.11	0.29
10895	77.15	77.68	74.54	0.20	0.04	0.21	0.13	0.10	0.31
11030	56.08	53.60	51.38	0.19	0.06	0.27	0.11	0.14	0.38
11060	49.48	46.61	44.03	0.17	0.07	0.30	0.08	0.17	0.43
11120	32.74	28.33	24.03	0.00	0.26	0.62	0.11	0.40	0.76
11130	29.24	24.36	19.50	0.07	0.36	0.84	0.18	0.51	0.97
11140	25.42	19.96	14.41	0.19	0.56	1.33	0.29	0.70	1.43
11155	18.99	12.45	6.37	0.54	1.40	4.56	0.63	1.51	4.49
11165	14.17	7.23	3.06	1.07	3.40	14.12	1.16	3.46	13.22
11170	11.64	5.02	2.48	1.57	5.74	20.24	1.67	5.75	18.58
11175	9.10	3.44	2.26	2.41	9.89	16.29	2.51	9.73	16.21
11180	6.72	2.55	2.15	3.84	16.80	14.26	3.95	16.10	14.38
11185	4.73	2.14	2.04	6.31	21.34	14.17	6.45	20.67	14.23
11200	2.09	1.74	1.70	23.02	16.79	23.88	24.86	17.13	20.93
11205	1.89	1.64	1.64	20.68	18.77	49.71	21.25	18.93	23.15
11210	1.76	1.56	1.61	19.29	22.73	25.26	19.39	21.97	21.10
11215	1.66	1.50	1.61	19.94	30.30	19.66	19.71	24.99	18.37
11225	1.50	1.44	1.63	26.34	22.65	15.50	24.64	20.91	15.44
11230	1.45	1.43	1.63	28.31	19.52	14.86	26.61	18.82	15.00
11235	1.41	1.43	1.62	24.49	17.90	14.81	24.58	17.64	15.09
11250	1.36	1.37	1.51	18.64	17.93	18.18	19.56	18.37	18.76
11255	1.34	1.35	1.47	18.50	19.29	20.93	19.51	19.99	21.47
11265	1.30	1.31	1.43	20.08	24.53	32.60	21.44	26.41	27.90
11275	1.27	1.30	1.44	23.98	26.73	24.28	25.66	26.43	22.07
11285	1.26	1.32	1.47	25.17	20.87	19.18	24.47	20.10	18.23
11290	1.27	1.33	1.49	23.04	19.11	18.07	22.07	18.47	17.40
11300	1.28	1.35	1.50	19.63	17.51	17.57	18.96	17.09	17.24
11310	1.30	1.36	1.50	18.53	17.96	19.07	18.02	17.66	18.82
11330	1.31	1.35	1.51	23.99	27.06	29.68	22.61	25.13	24.35
11350	1.43	1.46	1.60	19.35	19.21	21.47	18.80	17.98	19.14
11370	1.61	1.54	1.67	13.50	17.44	27.15	13.41	16.31	23.15
11380	1.61	1.53	1.77	13.38	21.41	28.74	13.41	19.66	27.61
11390	1.57	1.59	1.95	15.27	57.47	19.75	15.54	31.32	20.22
11395	1.55	1.66	2.08	17.48	25.86	18.02	17.94	26.62	18.45
11400	1.56	1.77	2.21	21.42	20.10	17.48	22.30	20.67	18.03
11405	1.60	1.91	2.37	30.53	17.19	18.06	32.95	17.58	19.12
11410	1.69	2.06	2.61	30.65	15.81	18.38	27.86	16.12	20.65
11425	2.15	2.65	5.22	17.16	17.78	6.40	16.57	19.39	6.80
11435	2.58	4.29	9.45	19.21	8.36	2.77	18.75	8.84	2.95
11445	3.89	8.30	14.38	10.67	3.30	1.53	10.73	3.49	1.62
11455	7.44	13.38	19.09	4.23	1.67	1.05	4.20	1.77	1.10
11470	14.94	20.55	25.34	1.56	0.95	0.76	1.51	1.00	0.78
11580	50.10	52.74	54.94	0.17	0.31	0.37	0.17	0.32	0.37
11730	74.59	76.22	77.76	0.03	0.18	0.28	0.01	0.19	0.30
11955	98.25	88.38	95.10	0.15	0.09	0.23	0.10	0.13	0.29
12500	100.72	93.75	92.39	0.22	0.04	0.22	0.17	0.08	0.29
13450	94.51	103.41	95.05	0.22	0.03	0.25	0.17	0.07	0.33
15850	112.23	92.94	87.02	0.29	0.01	0.26	0.19	0.12	0.42
17800	88.37	84.12	92.46	0.21	0.01	0.29	0.20	0.08	0.48
18400	75.86	72.23	70.56	0.09	0.14	0.36	0.17	0.08	0.47
20000	67.51	72.31	74.39	0.01	0.08	0.06	0.13	0.04	0.13

Typical Performance Data

FREQ. (MHz)	GROUP DELAY		
	(nsec)		
	@-40°C	@+25°C	@+85°C
11200	9.37	9.04	8.29
11205	9.31	8.75	7.93
11210	9.15	8.42	7.58
11215	8.92	8.07	7.28
11220	8.63	7.72	7.03
11225	8.31	7.41	6.82
11230	7.97	7.14	6.66
11235	7.65	6.92	6.52
11240	7.35	6.74	6.40
11245	7.10	6.59	6.30
11250	6.89	6.46	6.22
11255	6.72	6.36	6.14
11260	6.57	6.26	6.08
11265	6.45	6.18	6.03
11270	6.35	6.12	5.99
11275	6.26	6.06	5.96
11280	6.18	6.01	5.93
11285	6.12	5.97	5.91
11290	6.07	5.94	5.90
11295	6.02	5.92	5.89
11300	5.99	5.90	5.89
11305	5.96	5.89	5.89
11310	5.94	5.89	5.91
11315	5.93	5.89	5.93
11320	5.92	5.91	5.96
11325	5.92	5.93	6.00
11330	5.93	5.95	6.06
11335	5.94	5.99	6.12
11340	5.95	6.03	6.20
11345	5.98	6.09	6.28
11350	6.01	6.16	6.38
11355	6.05	6.24	6.50
11360	6.11	6.34	6.64
11365	6.18	6.45	6.81
11370	6.27	6.58	7.01
11375	6.37	6.74	7.25
11380	6.50	6.92	7.53
11385	6.65	7.15	7.83
11390	6.84	7.42	8.15
11395	7.05	7.73	8.45
11400	7.31	8.05	8.72

Typical Performance Curves

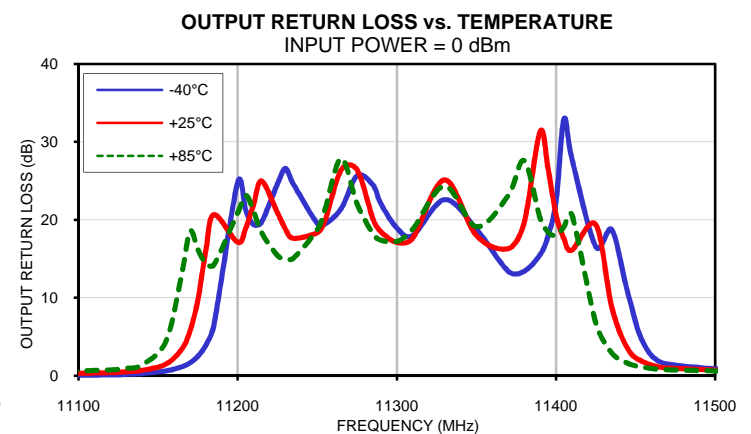
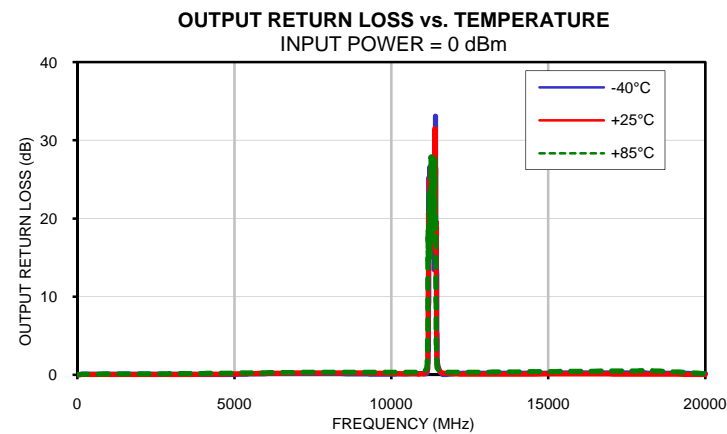
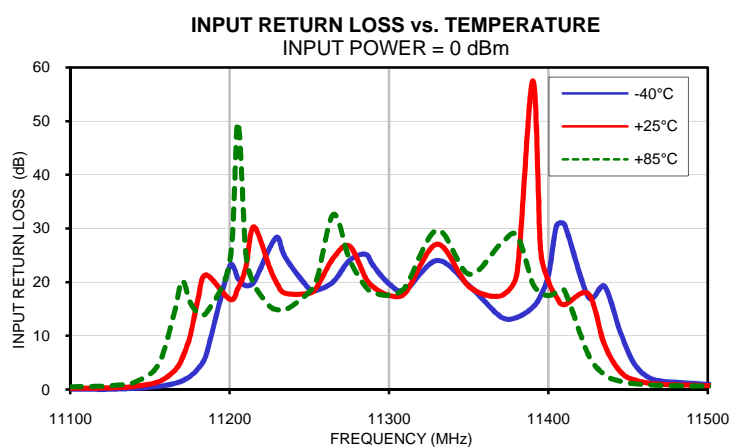
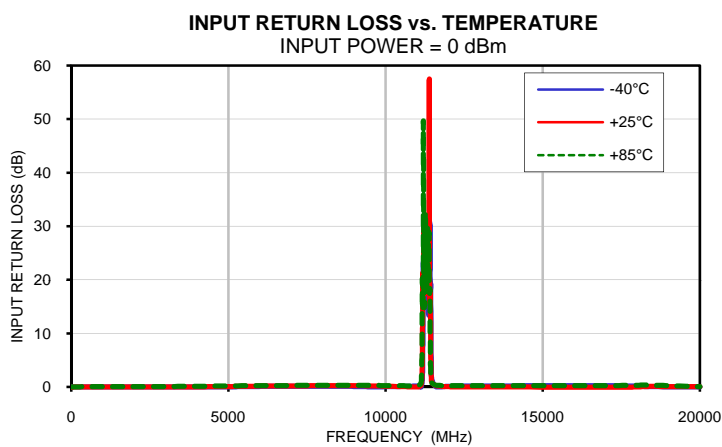
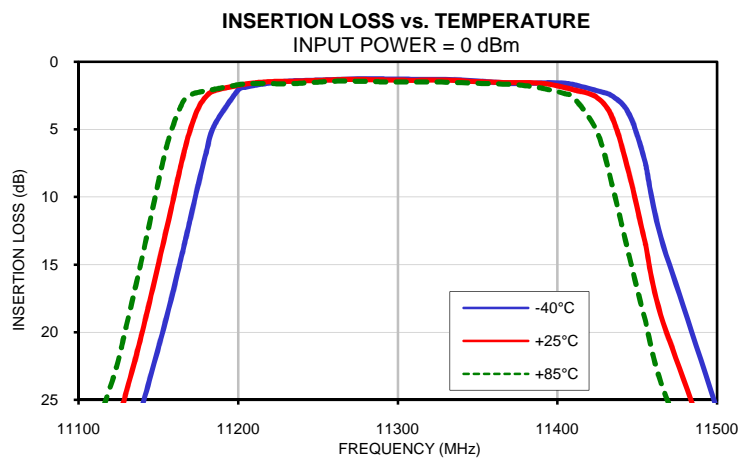
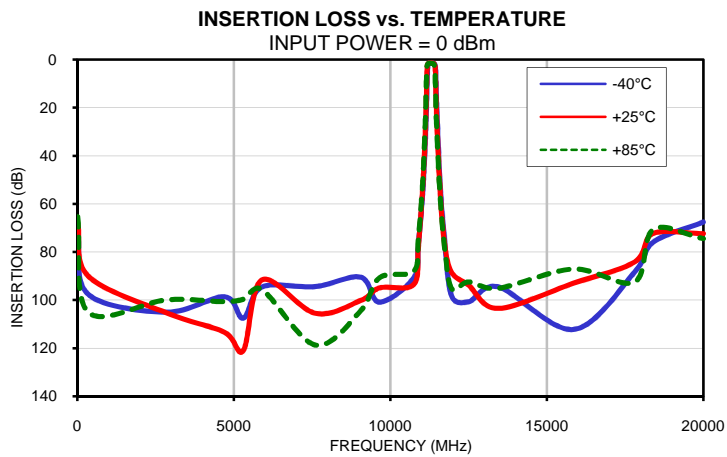

Typical Performance Curves

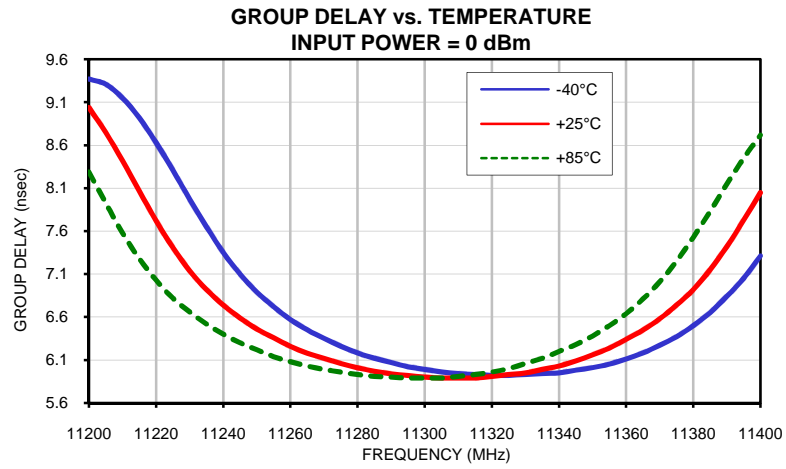

Outline Dimensions

PU2164

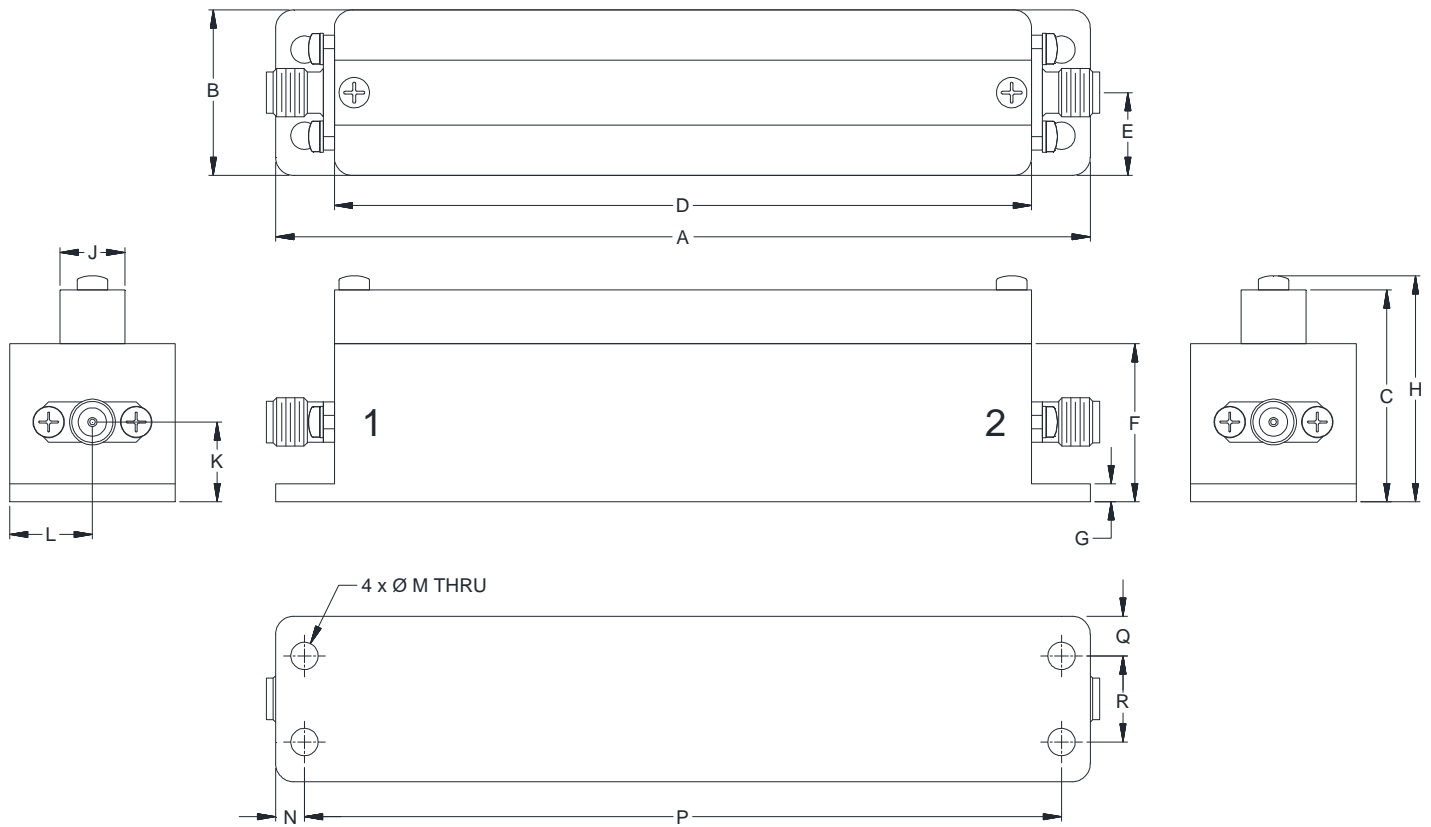

CASE#	A	B	C	D	E	F	G	H	J
PU2164	4.47 (113.43)	.91 (23.06)	1.16 (29.50)	3.82 (97.07)	.45 (11.53)	.87 (22.00)	.10 (2.50)	1.24 (31.48)	.36 (9.02)

CASE#	K	L	M	N	P	Q	R	WT. GRAMS
PU2164	.44 (11.10)	.45 (11.53)	.150 (3.81)	.16 (4.00)	4.151 (105.43)	.22 (5.53)	.472 (12.00)	113

Dimensions are in inches (mm). Tolerances: 2 Pl. $\pm .03$; 3 Pl. $\pm .015$

Notes:

1. Case material: Aluminum alloy.
2. Case finish: Powder coated over silver plating.
3. Refer to the individual model data sheet for the type of connectors available.

Mini-Circuits®
ISO 9001 ISO 14001 CERTIFIED

ALL NEW
minicircuits.com

P.O. Box 350166, Brooklyn, New York 11235-0003 (718) 934-4500 Fax (718) 332-4661 For detailed performance specs & shopping online see Mini-Circuits web site



The Design Engineers Search Engine Provides ACTUAL Data Instantly From MINI-CIRCUITS At: www.minicircuits.com

RF/IF MICROWAVE COMPONENTS

All Mini-Circuits products are manufactured under exacting quality assurance and control standards, and are capable of meeting published specifications after being subjected to any or all of the following physical and environmental test.

Specification	Test/Inspection Condition	Reference/Spec
Operating Temperature	-55° to 100°C Ambient Environment	Individual Model Data Sheet
Storage Temperature	-55° to 100° C Ambient Environment	Individual Model Data Sheet
Humidity	90 to 95% RH, 40°C, 96 hours; Units may require bake-out after humidity to restore full performance.	MIL-STD-202, Method 103, Condition B
Thermal Shock	-55° to 100°C, 100 cycles	MIL-STD-202, Method 107, Condition A-3, except +100°C
Vibration (High Frequency)	20g peak, 10-2000 Hz, 12 times in each of three perpendicular directions (total 36)	MIL-STD-202, Method 204, Condition D
Mechanical Shock	50g, 11ms half-sine, 3 shocks each direction 3 axes (total 18)	MIL-STD-202, Method 213, Condition A