



COAXIAL

Low Noise Amplifier

ZVA-543LN+ ZVA-543LNx+

50Ω 20 to 54 GHz NF 3.5 dB 1.85mm Female

THE BIG DEAL

- High Gain, 40 dB Typ. Over The Entire Operating Band
- Low Noise Figure, 3.5 dB Typ.
- High P_{SAT}, +29 dBm Typ.
- Wide DC Operating Voltage, +10 To +15 V
- Over Voltage and Reverse Voltage Protected



Generic photo used for illustration purposes only

APPLICATIONS

- Wideband Test and Instrumentation
- SATCOM
- 5G FR2 Millimeter Wave Testing
- Aerospace and Defense

FUNCTIONAL DIAGRAM

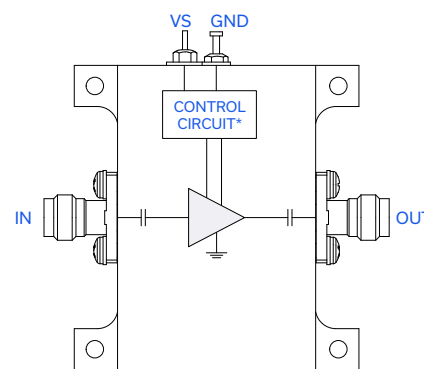

*Voltage Regulation, over-voltage, reverse voltage, and in-rush current protection circuit

PRODUCT OVERVIEW

Mini-Circuits' ZVA-543LN(X)+ is a wideband low noise, high power amplifier, operating from 20 to 54 GHz. This model operates over a single positive supply range of +10 to +15 V, allowing users to choose their desired operating voltage. Internal DC-DC conversion circuitry maintains constant efficiency over the full input voltage range. The amplifier incorporates several DC-protection features such as over-voltage, reverse-voltage, and in-rush current that protects the amplifier from damage if mishandled during operation.

KEY FEATURES

Feature	Advantages
High Frequency Amplifier, 20 to 54 GHz	A single versatile, broadband amplifier covers multiple 5G FR2 mmW bands up to 54 GHz, minimizing setup time and cost.
High Gain, 40 dB Typ. Low Noise Figure, 3.5 dB Typ High Output Power, +29 dBm Typ.	The combination of nearly 1 W typical saturated output power, high gain and low noise figure makes this amplifier an ideal choice as both a transmit and receive amplifier for Over-the-Air testing in all 5G FR2 bands. Additionally, the ZVA-543LN(X)+ is well suited as a driver in test bench applications, semiconductor chipset testing, as an LO driver for mixers and more..
Single Supply Voltage, +10 to +15 V	Internal regulation enables the amplifier to operate over a wide DC voltage range, simplifying implementation.
DC Protection <ul style="list-style-type: none"> • Over-voltage • Reverse voltage • In-rush current 	The internal DC circuitry allows the amplifier to be protected from external mishandling or unexpected spikes in voltage that could lead to catastrophic failures in the field.





COAXIAL

Low Noise Amplifier

ZVA-543LN+ ZVA-543LNX+



50Ω 20 to 54 GHz NF 3.5 dB 1.85mm Female

ELECTRICAL SPECIFICATIONS AT +25 °C BASEPLATE

Parameter	Condition (GHz)	Min.	Typ.	Max.	Units
Frequency Range	-	20	-	54	GHz
Gain	20 - 35	37.0	42.0	-	dB
	35 - 54	33.5	39.0	-	
Output Power at 1dB Compression (P1dB)	20 - 35	+27.0	+30.0	-	dBm
	35 - 54	+24.0	+27.0	-	
Saturated Output Power (P _{SAT}) ¹	20 - 35	+28.0	+31.0	-	dBm
	35 - 54	+26.0	+29.0	-	
Output IP3	20 - 54	-	+36.0	-	dBm
Input Return Loss	20 - 54	-	15.0	-	dB
Output Return Loss	20 - 54	-	15.0	-	dB
Noise Figure	20 - 35	-	3.5	-	dB
	35 - 54	-	4.5	-	
DC Supply Voltage (V _S)		+10	-	+15	V
DC Current at V _S = +10V (Without/With Heatsink)		-	1500/1650	2500/2650 ²	mA

1. At P_{SAT}, P_{OUT} changes less than 0.1 dB for a 1 dB change in P_{IN}

2. Typical current measured under small signal conditions. Max DC current measured at P_{SAT}. DC current increases as amplifier is driven into compression.





COAXIAL

Low Noise Amplifier

ZVA-543LN+ ZVA-543LNX+



50Ω 20 to 54 GHz NF 3.5 dB 1.85mm Female

TYPICAL PERFORMANCE GRAPHS

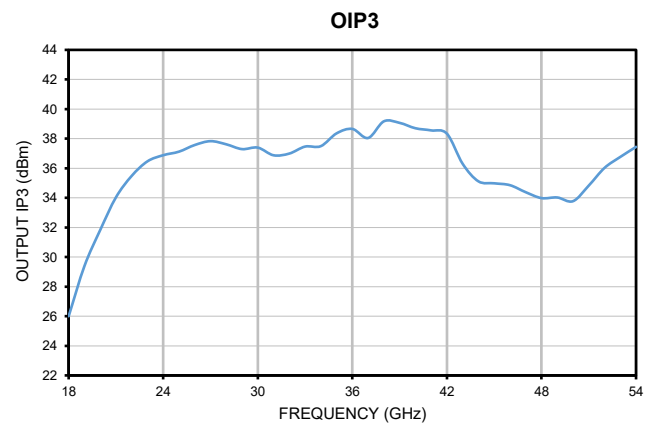
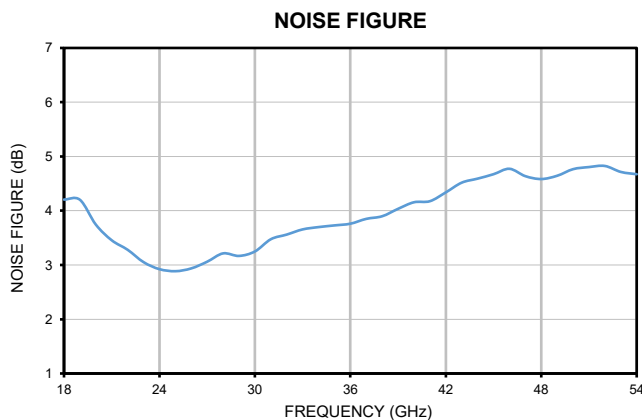
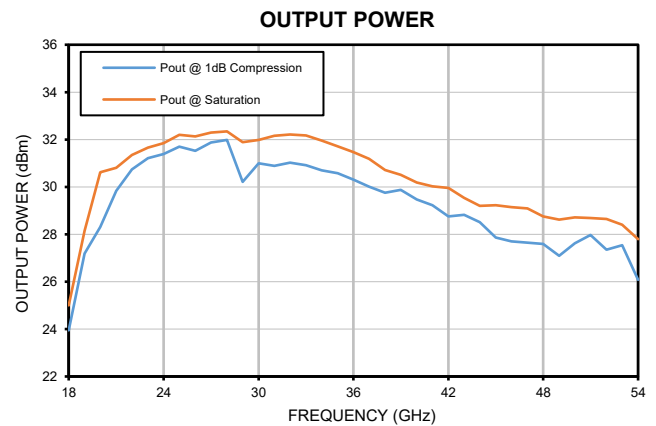
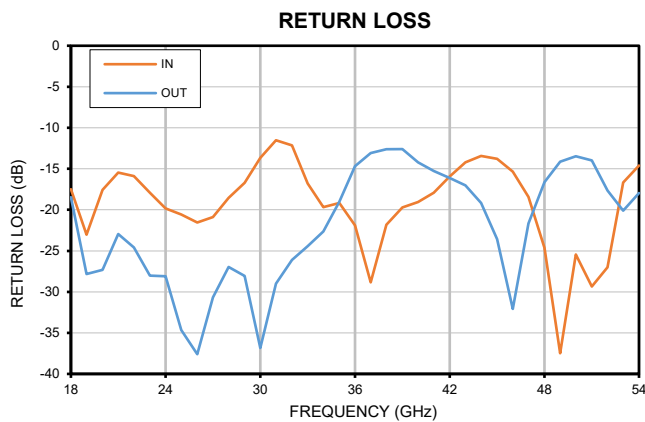
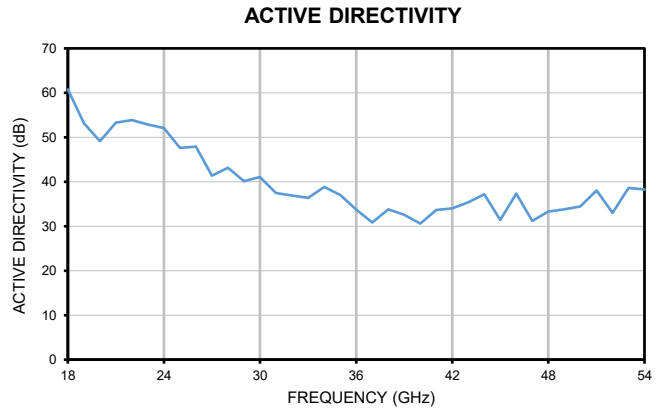
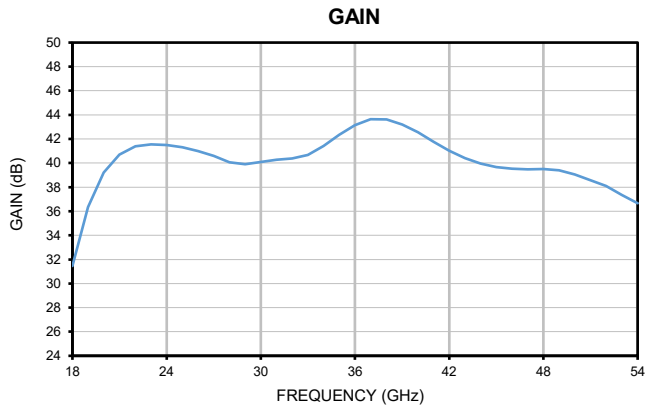



COAXIAL

Low Noise Amplifier

ZVA-543LN+ ZVA-543LNX+

Mini-Circuits

50Ω 20 to 54 GHz NF 3.5 dB 1.85mm Female

ABSOLUTE MAXIMUM RATINGS³

Parameter	Ratings
Operating Temperature	ZVA-543LN+ -40 °C to +50°C Ambient
	ZVA-543LNX+ -40 °C to +60°C Baseplate
Storage Temperature	-40 °C to +85°C
Total Power Dissipation	24.5 W
RF Input Power ⁴ (CW)	+5 dBm
DC Operating Voltage	+16 V

3. Continuous operation is not recommended at these extremes. Permanent damage may occur if any of these limits are exceeded.

4. Specified under matched load to 50 ohms.

DETERMINING MAXIMUM THERMAL RESISTANCE OF USERS' EXTERNAL HEAT SINK

$\text{MAXIMUM THERMAL RESISTANCE}$	$= \frac{\text{MAXIMUM OPERATING CASE TEMP} - \text{MAXIMUM USER AMBIENT TEMP}}{\text{POWER DISSIPATION}}$
Example:	<p>MAXIMUM OPERATING CASE TEMP = 60 °C (CHECK MAXIMUM RATINGS TABLE FOR THIS VALUE)</p> <p>MAXIMUM USER AMBIENT TEMP = 30 °C (USER DEFINED)</p> <p>POWER DISSIPATION = 24.5 WATTS (CHECK MAXIMUM RATINGS TABLE FOR THIS VALUE)</p> <p>THEN MAXIMUM ALLOWABLE THERMAL RESISTANCE = 1.2 °C/W</p>



COAXIAL

Low Noise Amplifier

ZVA-543LN+ ZVA-543LNx+

Mini-Circuits

50Ω 20 to 54 GHz NF 3.5 dB 1.85mm Female

OUTLINE DRAWING FOR MODELS WITH HEATSINK (ZVA-543LN+)

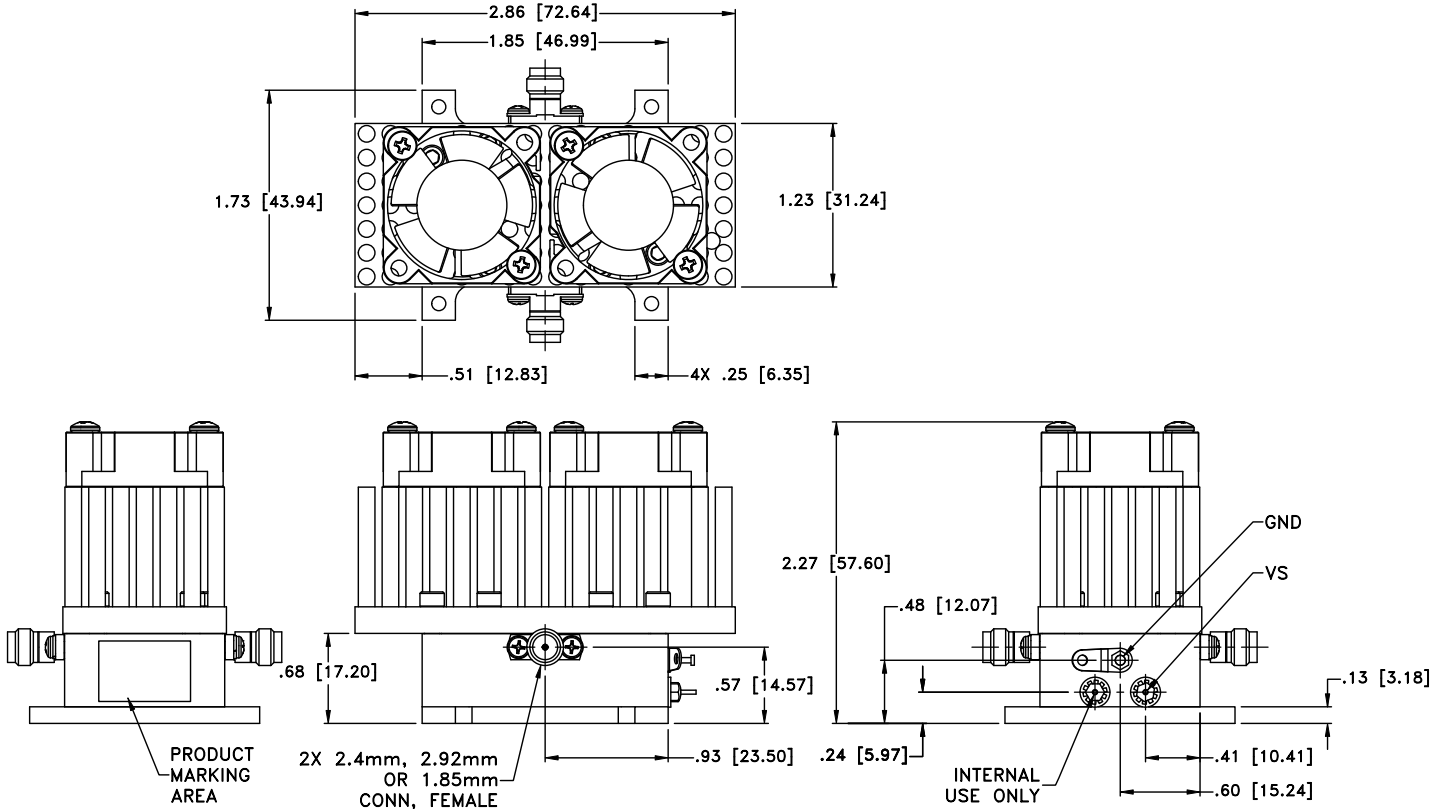

MOUNTING INFORMATION FOR MODELS WITHOUT HEATSINK (ZVA-543LNx+)

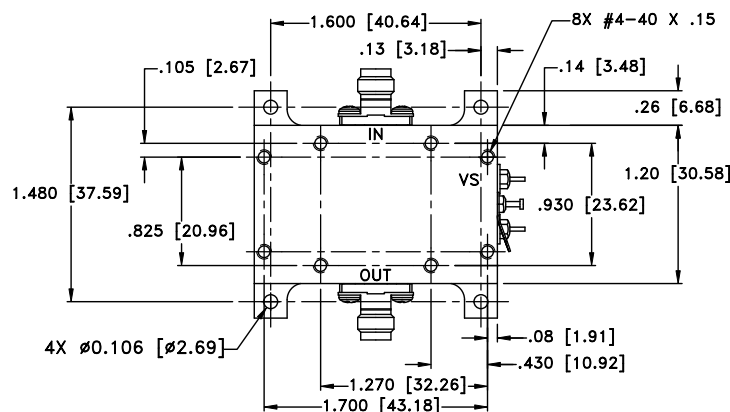

Weight: 160 grams; Without Heatsink: 60 grams
Dimensions are in inches [mm]. Tolerances: 2 Pl.±.03; 3Pl.±.015

Mini-Circuits



COAXIAL

Low Noise Amplifier

ZVA-543LN+ ZVA-543LNX+



50Ω 20 to 54 GHz NF 3.5 dB 1.85mm Female

ADDITIONAL INFORMATION IS AVAILABLE ON OUR DASHBOARD.

Performance Data	Data Table
	Swept Graphs
	S-Parameter (S2P Files) Data Set (.zip file)
RoHs Status	Compliant
Environmental Ratings	ENV130
Export Information	ECCN #3A001.B.4 This item will require an export license when shipped to certain countries.

ORDERING INFORMATION

Model No. Links	ZVA-543LN+	ZVA-543LNX+
Option	With heatsink	Without heatsink
Product Marking	ZVA-543LN+	ZVA-543LNX+
Case Style	VN3071-4	
Connector	1.85 mm (Female)	

- NOTES**
- A. Performance and quality attributes and conditions not expressly stated in this specification document are intended to be excluded and do not form a part of this specification document.
 - B. Electrical specifications and performance data contained in this specification document are based on Mini-Circuit's applicable established test performance criteria and measurement instructions.
 - C. The parts covered by this specification document are subject to Mini-Circuits standard limited warranty and terms and conditions (collectively, "Standard Terms"); Purchasers of this part are entitled to the rights and benefits contained therein. For a full statement of the standard. Terms and the exclusive rights and remedies thereunder, please visit Mini-Circuits' website at www.minicircuits.com/MCLStore/terms.jsp



Typical Performance Data

FREQUENCY (GHz)	GAIN (dB)	ACTIVE DIRECTIVITY (dB)	RETURN LOSS (dB)		Pout @ 1 dB COMPRESSION (dBm)	Pout at SATURATION (dBm)	NOISE FIGURE (dB)	OIP3 (dBm)
			IN	OUT				
18	31.5	60.8	17.5	18.5	23.9	25.0	4.2	26.00
19	36.4	53.1	23.0	27.8	27.2	28.1	4.2	29.39
20	39.2	49.1	17.6	27.3	28.3	30.6	3.7	31.82
21	40.7	53.3	15.4	22.9	29.8	30.8	3.5	34.03
22	41.4	53.9	15.9	24.6	30.7	31.4	3.3	35.48
23	41.6	52.9	17.9	28.0	31.2	31.7	3.1	36.47
24	41.5	52.0	19.8	28.1	31.4	31.8	2.9	36.88
25	41.3	47.6	20.6	34.6	31.7	32.2	2.9	37.12
26	41.0	47.9	21.6	37.6	31.5	32.1	2.9	37.57
27	40.6	41.3	20.9	30.7	31.9	32.3	3.1	37.83
28	40.1	43.2	18.5	27.0	32.0	32.3	3.2	37.62
29	39.9	40.2	16.7	28.1	30.2	31.9	3.2	37.29
30	40.1	41.1	13.7	36.8	31.0	32.0	3.2	37.39
31	40.3	37.5	11.5	29.0	30.9	32.2	3.5	36.88
32	40.4	36.9	12.1	26.1	31.0	32.2	3.6	36.99
33	40.7	36.4	16.8	24.4	30.9	32.2	3.7	37.46
34	41.4	38.8	19.7	22.6	30.7	32.0	3.7	37.49
35	42.3	37.1	19.2	19.0	30.6	31.7	3.7	38.36
36	43.1	33.7	21.9	14.7	30.3	31.5	3.8	38.66
37	43.6	30.9	28.8	13.1	30.0	31.2	3.8	38.04
38	43.6	33.8	21.8	12.6	29.8	30.7	3.9	39.17
39	43.2	32.6	19.7	12.6	29.9	30.5	4.0	39.07
40	42.6	30.6	19.1	14.2	29.5	30.2	4.2	38.71
41	41.8	33.7	17.9	15.3	29.2	30.0	4.2	38.56
42	41.0	34.1	15.9	16.1	28.7	30.0	4.3	38.33
43	40.4	35.4	14.2	17.0	28.8	29.5	4.5	36.30
44	40.0	37.2	13.4	19.2	28.5	29.2	4.6	35.11
45	39.7	31.4	13.8	23.6	27.9	29.2	4.7	34.98
46	39.5	37.4	15.3	32.1	27.7	29.1	4.8	34.86
47	39.5	31.2	18.4	21.7	27.6	29.1	4.6	34.38
48	39.5	33.3	24.6	16.6	27.6	28.8	4.6	33.98
49	39.4	33.8	37.5	14.1	27.1	28.6	4.6	34.02
50	39.0	34.5	25.5	13.5	27.6	28.7	4.8	33.78
51	38.6	38.0	29.3	14.0	28.0	28.7	4.8	34.83
52	38.1	33.0	27.0	17.6	27.4	28.6	4.8	36.02
53	37.3	38.6	16.7	20.1	27.5	28.4	4.7	36.77
54	36.7	38.3	14.6	17.9	26.1	27.8	4.7	37.44

Coaxial Amplifier

Typical Performance Curves

ZVA-543LN(X)+

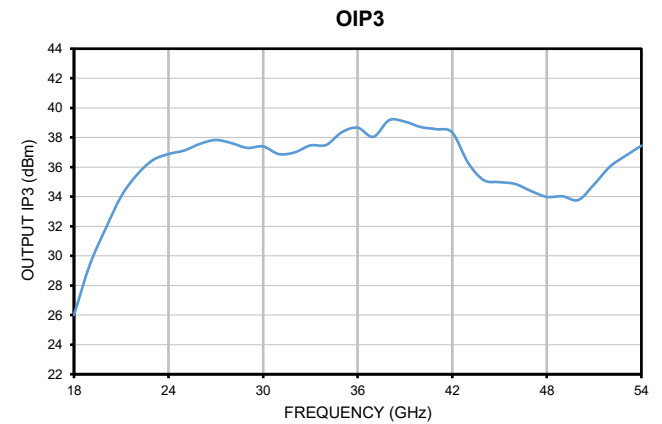
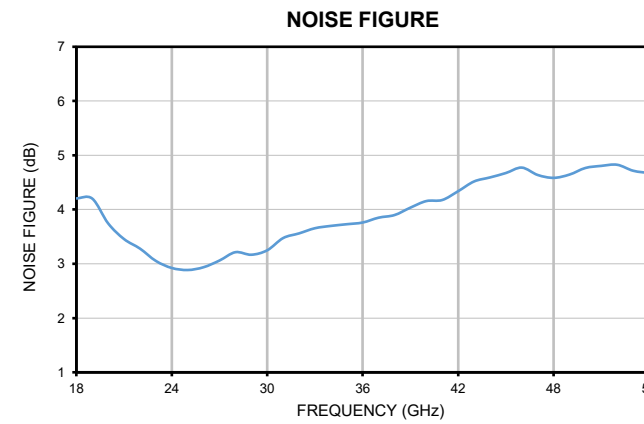
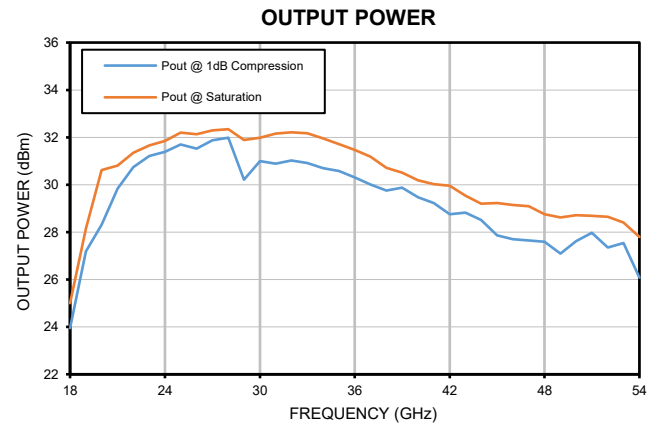
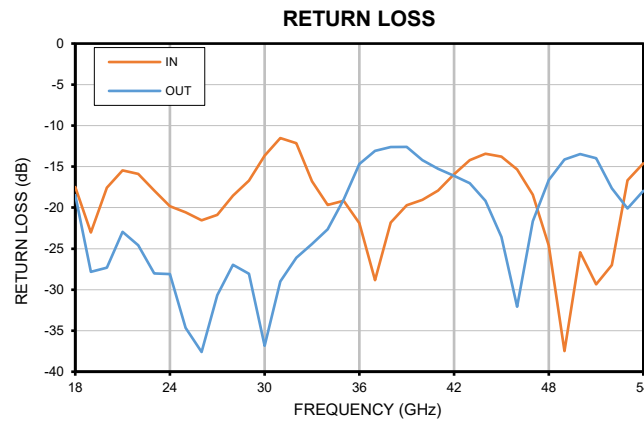
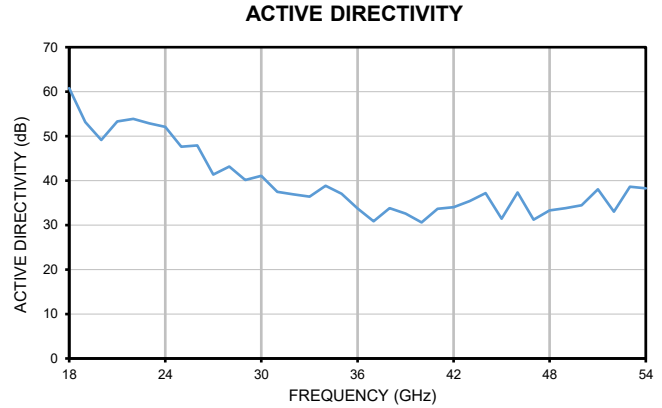
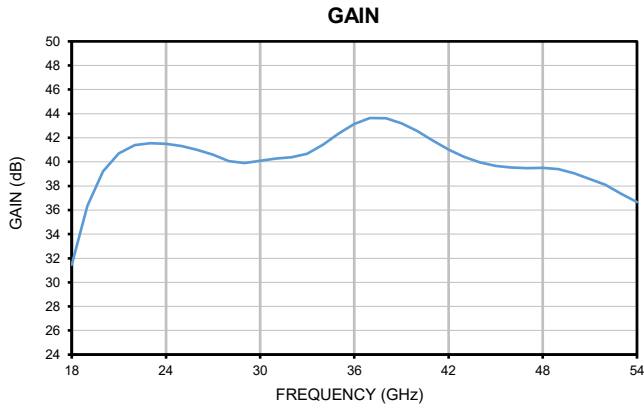

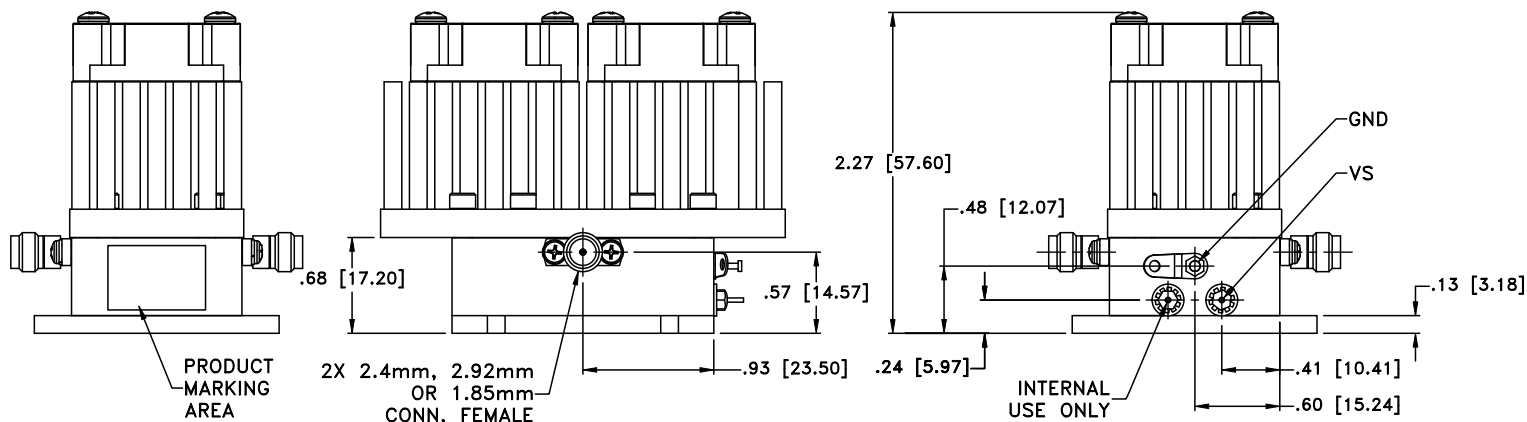
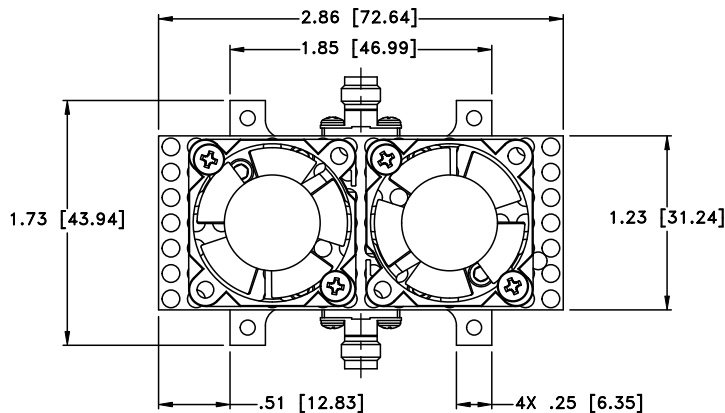

OQWPVKP I'KPHQTOCVKQP'QH'OQFGN'YIVJQWV'JGCVUKPM

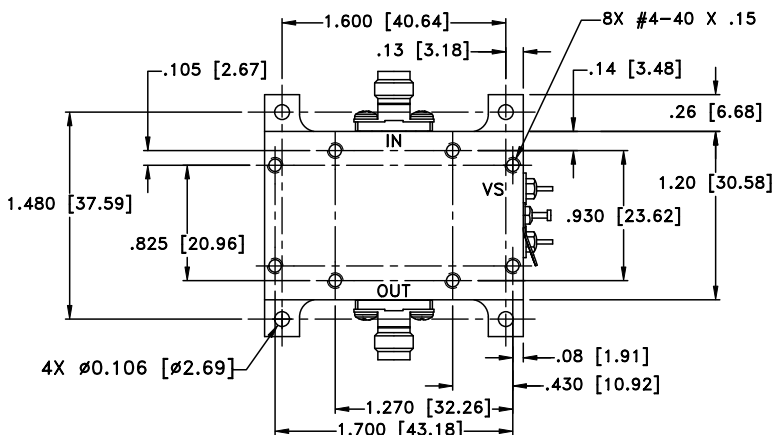

Y V0 Y V0I TCO U'382'i tco u=""Y KJ QWV'J GCVUKPMI TCO U'82'i tco u"

Flo gpukqpu'ctg'lp'pej gu"o o #0Vqrgtcegu<4'Rr0025="5'Rr000237"

Pqvgu<

30 Ecug'o cvgtkn<Cno kpwo 0

40 Ecug'hpkuj <I qif 'r rvpki =

50 J gcvukpmihpkuj <""Drcen'cpqf k g0

60 Tghgt'vq'v'g'lpf kxf wcnb qf gnf'cvc'uj gg'vht'v'g'v'r g'qh'epppgevqtu'cxckrdrg0

70 Uj cr g'qh'epppgevqt'hrpi g'o c{ 'xct{0



P.O. Box 350166, Brooklyn, New York 11235-0003 (718) 934-4500 Fax (718) 332-4661 For detailed performance specs & shopping online see Mini-Circuits web site

The Design Engineers Search Engine Provides ACTUAL Data Instantly From MINI-CIRCUITS At: www.minicircuits.com



RF/IF MICROWAVE COMPONENTS



All Mini-Circuits products are manufactured under exacting quality assurance and control standards, and are capable of meeting published specifications after being subjected to any or all of the following physical and environmental test.

Specification	Test/Inspection Condition	Reference/Spec
Operating Temperature	-40° to +60° C Baseplate Temp	Individual Model Data Sheet
Storage Temperature	-40° to +85° C Ambient Environment	Individual Model Data Sheet
Burn-in	(DC on) 72 hours at 25°C	----
Thermal Shock	-40° C to +85°C, 100 cycles	Transition time = 5 mins, Dwell time = 30 mins
Vibration	Random Vibration (non-operating)	MIL-STD-883K, Method 2025, Cond. 1A