



MEDIUM POWER, HIGH GAIN

Wideband Amplifier

ZVA-543HP+ ZVA-543HPX+

Mini-Circuits

50Ω 18 to 54 GHz 1.85mm Female

THE BIG DEAL

- High gain, 31 dB typ. over the entire operating band
- Good gain flatness, ± 2.0 dB typ.
- +29 dBm Psat Typ.
- Adjustable DC voltage, +10 to +15 V
- DC protected against over-voltage, reverse-voltage conditions

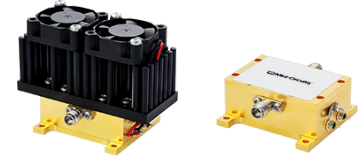

Generic photo used for illustration purposes only

Model No.	ZVA-543HP+	ZVA-543HPX+
Option	With heatsink & fan	Without heatsink & fan
Case Style	VN3071-4	
Connector	1.85mm Female	

+RoHS Compliant

The +Suffix identifies RoHS Compliance.
See our website for methodologies and qualifications

APPLICATIONS

- Wideband Test and Instrumentation
- 5G mmW
- SATCOM
- Wireless Infrastructure

PRODUCT OVERVIEW

Mini-Circuits' ZVA-543HP(X)+ is a coaxial, 1-watt wideband high gain amplifier, operating from 18 to 54 GHz. This model operates over a single positive supply range of +10 to +15 V, allowing users to choose their desired operating voltage. Internal DC-DC conversion circuitry maintains constant efficiency over the full input voltage range. The amplifier incorporates several DC-protection features, such as over-voltage, reverse voltage and in-rush current, that protect the amplifier from damage if mishandled during operation. The wideband operation combined with high output power makes this amplifier an ideal choice for testing and instrumentation applications.

KEY FEATURES

Features	Advantages
Wideband amplifier, 18 to 54 GHz	A single amplifier serves the need for applications including 5G bands (24 to 54 GHz), SATCOM, Test & Instrumentation, etc.
Integrated fan assembly	Model ZVA-543HP+ utilizes two integrated fans, keeping the amplifier cool to the touch during normal operation at room temperature
High gain Low VSWR Medium RF power	The amplifier provides 31 dB (typ.) of gain over the entire operating band, and is capable of delivering over 1 watt of RF power
Adjustable DC Supply Voltage	The device is capable of operating from +10 to +15 V with consistent DC power consumption
DC protection – Over-voltage Reverse voltage In-rush current	The internal DC circuitry allows the amplifier to be protected from external mishandling that could lead to catastrophic failures in the field





MEDIUM POWER, HIGH GAIN

Wideband Amplifier

ZVA-543HP+ ZVA-543HPX+

Mini-Circuits

50Ω 18 to 54 GHz 1.85mm Female

ELECTRICAL SPECIFICATIONS AT 25 °C BASEPLATE

Parameter	Condition (GHz)	ZVA-543HP+ ³ ZVA-543HPX+ ⁴			Units
		Min.	Typ.	Max.	
Frequency Range	-	18	-	54	GHz
Gain	18-20	-	29.0	-	dB
	20-40	29.0	33.0	-	
	40-54	28.0	31.0	-	
Output Power at 1dB compression	18-20	-	27.0	-	dBm
	20-40	27.0	30.0	-	
	40-54	24.5	27.5	-	
Saturated Output Power	18-20	-	28.0	-	dBm
	20-40	28.0	31.0	-	
	40-54	26.0	28.5	-	
Output IP3 (Output Power = +14 dBm/tone)	18 - 54	-	37.0	-	dBm
Input VSWR	18 - 54	-	1.5	2.0	:1
Output VSWR ¹	18 - 54	-	1.5	2.0	:1
Noise Figure	18 - 50	-	6.5	-	dB
Operating DC Voltage	-	+10	-	+15	V
Device Operating Current at +10 V	-	-	1500 ⁴ / 1650 ³	2400 ⁴ / 2550 ³	mA

1. Open and short-circuit loads are not recommended at the amplifier output. Ensure proper 50 Ohm load before turning the amplifier "ON".
2. Device operating power based on current when amplifier is in saturation.
3. For units with heatsink, limit ambient temperature to 50 °C.
4. For units without heatsink, limit the maximum baseplate temperature to 60 °C.

MAXIMUM RATINGS⁶

Parameter	Ratings
Operating Temperature	ZVA-543HP+ -40 °C to +50 °C Ambient ZVA-543HPX+ -40 °C to +60 °C Baseplate
Storage Temperature	-40 °C to +85 °C
Total Power Dissipation	22.5 W
RF Input Power ⁵ (CW)	+5 dBm
DC Operating Voltage	+16 V

5. Specified under matched load to 50 ohms.
6. Continuous operation is not recommended at these extremes. Permanent damage may occur if any of these limits are exceeded.

DETERMINING MAXIMUM THERMAL RESISTANCE OF USERS' EXTERNAL HEAT SINK

$\text{MAXIMUM THERMAL RESISTANCE} = \frac{\text{MAXIMUM OPERATING CASE TEMP} - \text{MAXIMUM USER AMBIENT TEMP}}{\text{POWER DISSIPATION}}$	
Example:	MAXIMUM OPERATING CASE TEMP = 50 °C (CHECK MAXIMUM RATINGS TABLE FOR THIS VALUE) MAXIMUM USER AMBIENT TEMP = 30 °C (USER DEFINED) POWER DISSIPATION = 10 WATTS (CHECK MAXIMUM RATINGS TABLE FOR THIS VALUE) THEN MAXIMUM ALLOWABLE THERMAL RESISTANCE = 2 °C/W





MEDIUM POWER, HIGH GAIN

Wideband Amplifier

ZVA-543HP+ ZVA-543HPX+

Mini-Circuits

50Ω 18 to 54 GHz 1.85mm Female

OUTLINE DRAWING FOR MODELS WITH HEATSINK (ZVA-543HP+)

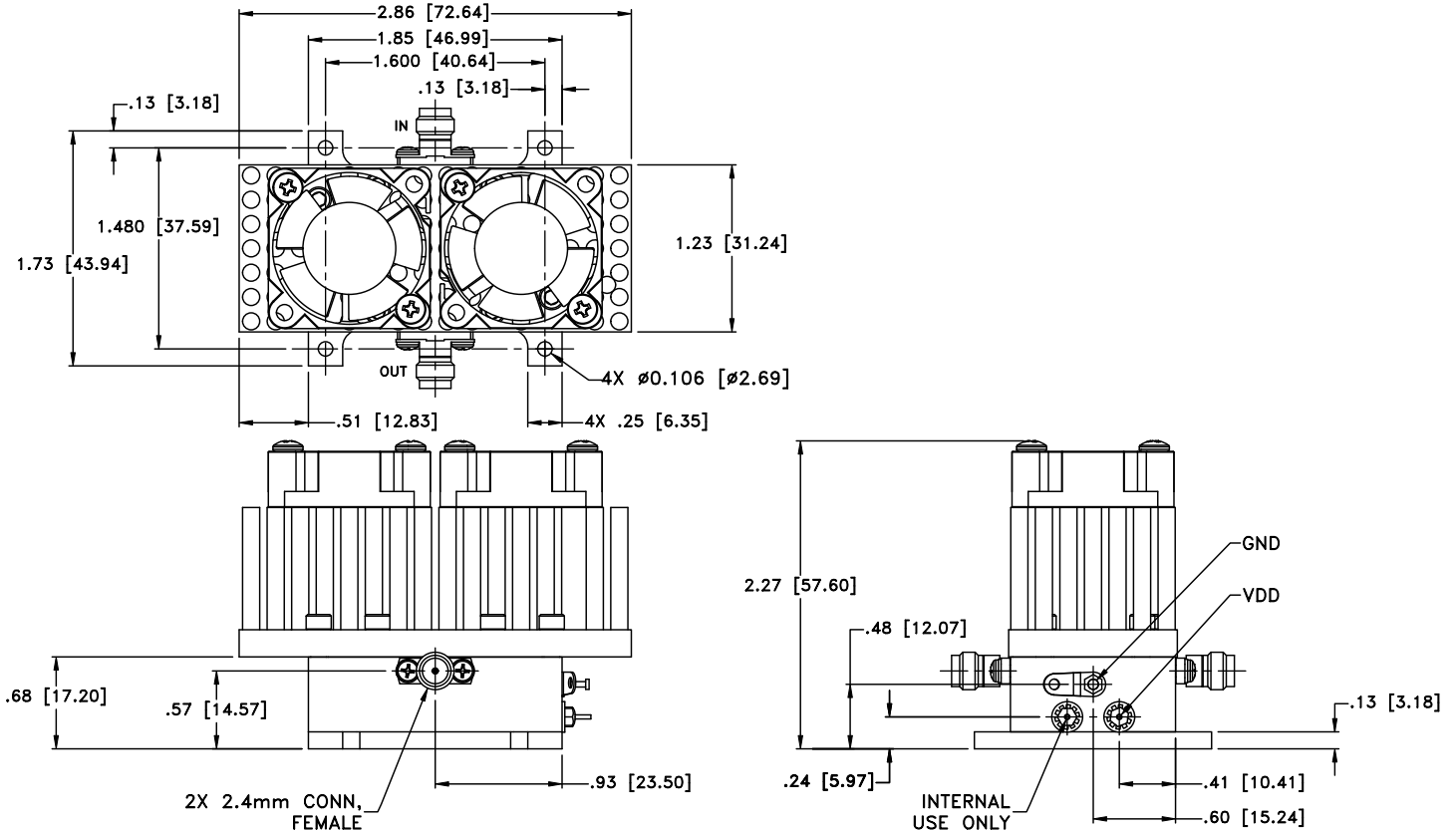

MOUNTING INFORMATION FOR MODELS WITHOUT HEATSINK (ZVA-543HPX+)

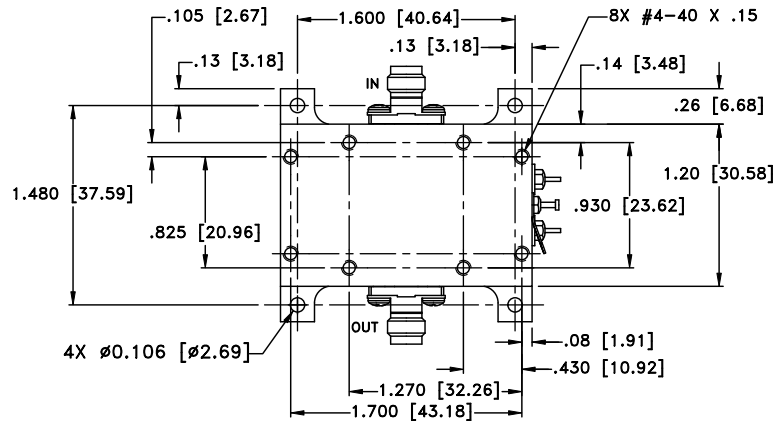

WT. GRAMS 160 grams; WITHOUT HEATSINK GRAMS 60 grams
Dimensions are in inches [mm]. Tolerances: 2 Pl. ±.03; 3 Pl. ±.015





MEDIUM POWER, HIGH GAIN

Wideband Amplifier

ZVA-543HP+ ZVA-543HPX+

Mini-Circuits

50Ω 18 to 54 GHz 1.85mm Female

TYPICAL PERFORMANCE DATA / GRAPHS

Frequency (GHz)	Gain (dB) 10V	Directivity (dB) 10V	VSWR (:1) 10V		Pout @ 1 dB Compression (dBm) 10V	Pout @ Saturation (dBm) 10V	Output IP3 (dBm) 10V	Noise Figure (dB) 10V
			IN	OUT				
18.0	26.7	63.9	1.1	1.4	24.5	25.0	27.4	5.3
20.0	31.7	61.3	1.2	1.1	28.9	29.5	32.2	5.5
22.0	32.8	60.7	1.3	1.2	30.5	30.8	34.6	5.4
24.0	33.2	59.3	1.2	1.1	31.0	31.2	35.6	5.4
26.0	33.5	57.3	1.2	1.1	31.1	31.5	36.0	5.6
28.0	33.0	53.3	1.2	1.2	31.5	31.9	37.2	6.0
30.0	32.5	55.1	1.2	1.1	30.7	31.7	36.0	6.3
32.0	32.7	54.0	1.3	1.1	31.0	31.8	37.0	6.8
34.0	33.3	48.8	1.4	1.2	30.7	31.6	36.9	7.0
36.0	33.7	47.2	1.2	1.5	30.1	30.9	35.7	7.1
38.0	33.8	49.2	1.3	1.9	29.6	30.5	35.9	7.4
40.0	32.8	50.8	1.1	1.9	29.1	29.5	38.2	7.6
42.0	31.1	50.3	1.1	1.8	28.6	29.1	36.4	8.1
44.0	30.3	48.3	1.3	1.5	28.3	28.7	37.7	8.3
46.0	30.2	49.5	1.3	1.1	27.6	28.5	37.1	8.6
48.0	30.3	46.8	1.4	1.3	27.3	28.1	35.2	9.0
50.0	30.3	46.9	1.4	1.7	27.0	27.9	34.1	9.2
52.0	30.9	47.8	1.5	1.8	27.4	27.8	33.8	
54.0	32.4	46.5	1.1	1.6	26.6	27.4	35.1	

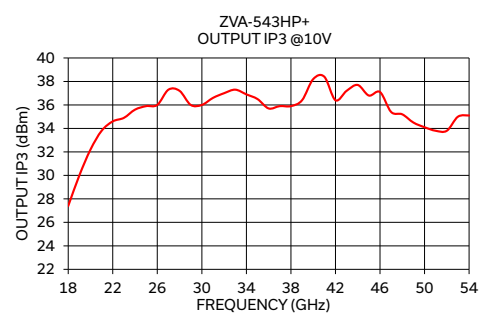
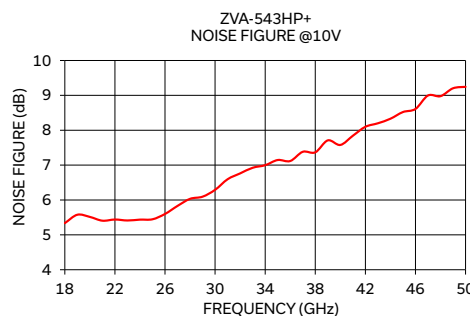
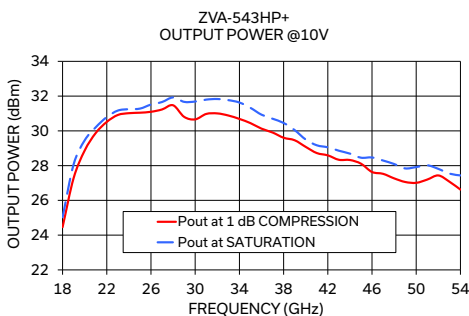
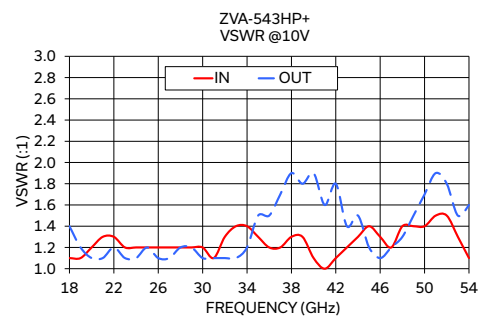
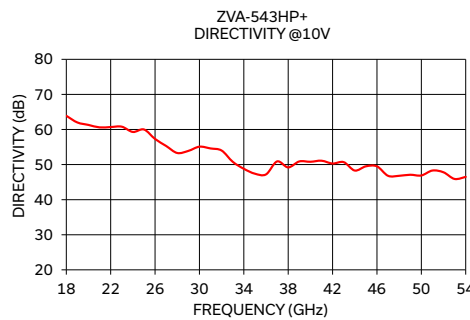
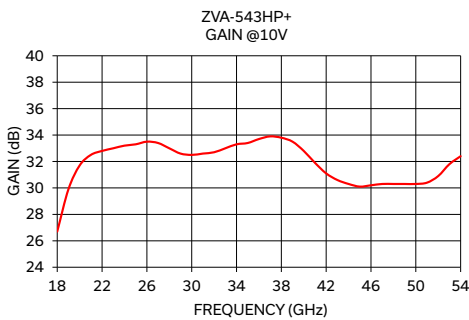

Coaxial Amplifier

ZVA-543HP(X)+

Typical Performance Data

FREQUENCY (GHz)	GAIN (dB) 10V	DIRECTIVITY (dB) 10V	VSWR (:1)		OIP3 (dBm) 10V	Pout @ 1 dB COMPRESSION (dBm) 10V	Pout at SATURATION (dBm) 10V	Noise Figure (dB) 10V
			IN 10V	OUT 10V				
18.0	26.7	63.9	1.1	1.4	27.4	24.5	25.0	5.3
19.0	29.9	62.0	1.1	1.2	30.0	27.3	28.1	5.6
20.0	31.7	61.3	1.2	1.1	32.2	28.9	29.5	5.5
21.0	32.5	60.6	1.3	1.1	33.8	29.9	30.2	5.4
22.0	32.8	60.7	1.3	1.2	34.6	30.5	30.8	5.4
23.0	33.0	60.8	1.2	1.1	34.9	30.9	31.2	5.4
24.0	33.2	59.3	1.2	1.1	35.6	31.0	31.2	5.4
25.0	33.3	60.0	1.2	1.2	35.9	31.0	31.3	5.4
26.0	33.5	57.3	1.2	1.1	36.0	31.1	31.5	5.6
27.0	33.4	55.3	1.2	1.1	37.3	31.2	31.7	5.8
28.0	33.0	53.3	1.2	1.2	37.2	31.5	31.9	6.0
29.0	32.6	53.9	1.2	1.2	36.0	30.8	31.7	6.1
30.0	32.5	55.1	1.2	1.1	36.0	30.7	31.7	6.3
31.0	32.6	54.6	1.1	1.1	36.6	31.0	31.8	6.6
32.0	32.7	54.0	1.3	1.1	37.0	31.0	31.8	6.8
33.0	33.0	50.8	1.4	1.1	37.3	30.9	31.8	6.9
34.0	33.3	48.8	1.4	1.2	36.9	30.7	31.6	7.0
35.0	33.4	47.4	1.3	1.5	36.5	30.4	31.3	7.1
36.0	33.7	47.2	1.2	1.5	35.7	30.1	30.9	7.1
37.0	33.9	50.9	1.2	1.7	35.9	29.9	30.7	7.4
38.0	33.8	49.2	1.3	1.9	35.9	29.6	30.5	7.4
39.0	33.5	50.9	1.3	1.8	36.4	29.5	30.0	7.7
40.0	32.8	50.8	1.1	1.9	38.2	29.1	29.5	7.6
41.0	31.9	51.1	1.0	1.6	38.4	28.7	29.2	7.8
42.0	31.1	50.3	1.1	1.8	36.4	28.6	29.1	8.1
43.0	30.6	50.7	1.2	1.4	37.2	28.3	28.9	8.2
44.0	30.3	48.3	1.3	1.5	37.7	28.3	28.7	8.3
45.0	30.1	49.5	1.4	1.2	36.8	28.1	28.5	8.5
46.0	30.2	49.5	1.3	1.1	37.1	27.6	28.5	8.6
47.0	30.3	46.8	1.2	1.2	35.4	27.5	28.3	9.0
48.0	30.3	46.8	1.4	1.3	35.2	27.3	28.1	9.0
49.0	30.3	47.1	1.4	1.5	34.5	27.1	27.8	9.2
50.0	30.3	46.9	1.4	1.7	34.1	27.0	27.9	9.2
51.0	30.4	48.3	1.5	1.9	33.8	27.2	28.0	-
52.0	30.9	47.8	1.5	1.8	33.8	27.4	27.8	-
53.0	31.8	45.9	1.3	1.5	35.0	27.1	27.5	-
54.0	32.4	46.5	1.1	1.6	35.1	26.6	27.4	-

Coaxial Amplifier

ZVA-543HP(X)+

Typical Performance Curves

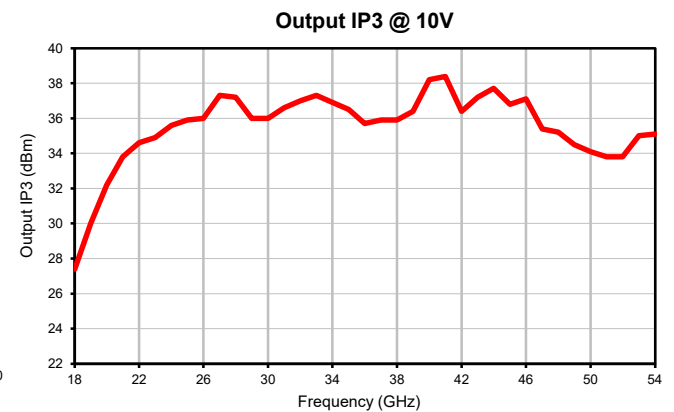
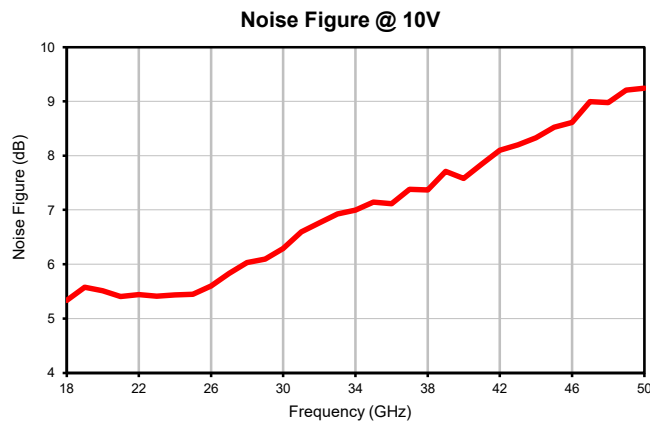
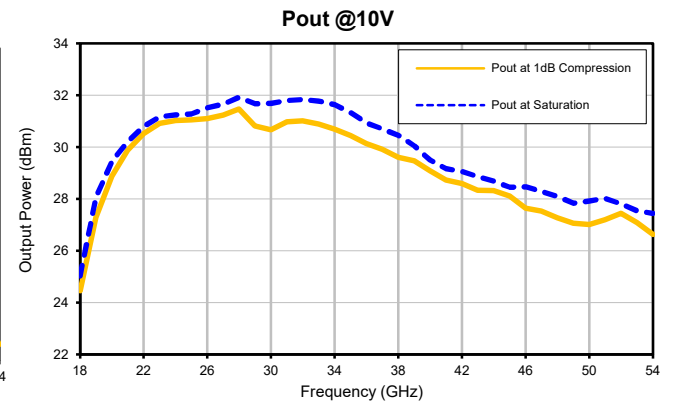
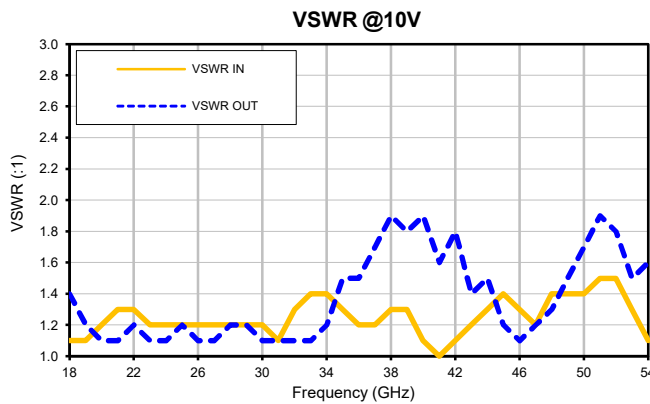
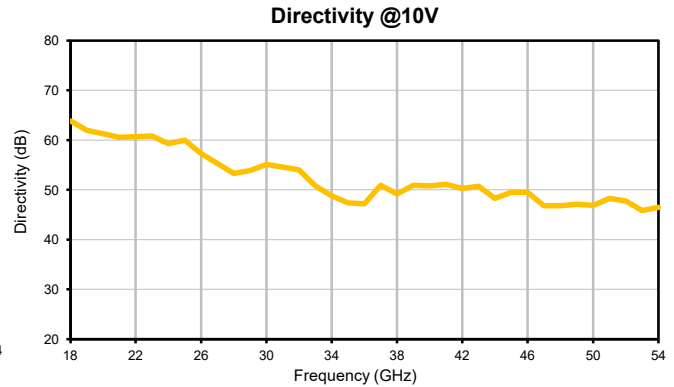
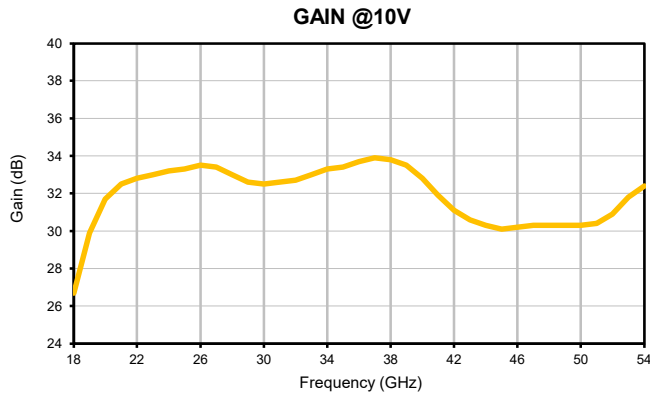

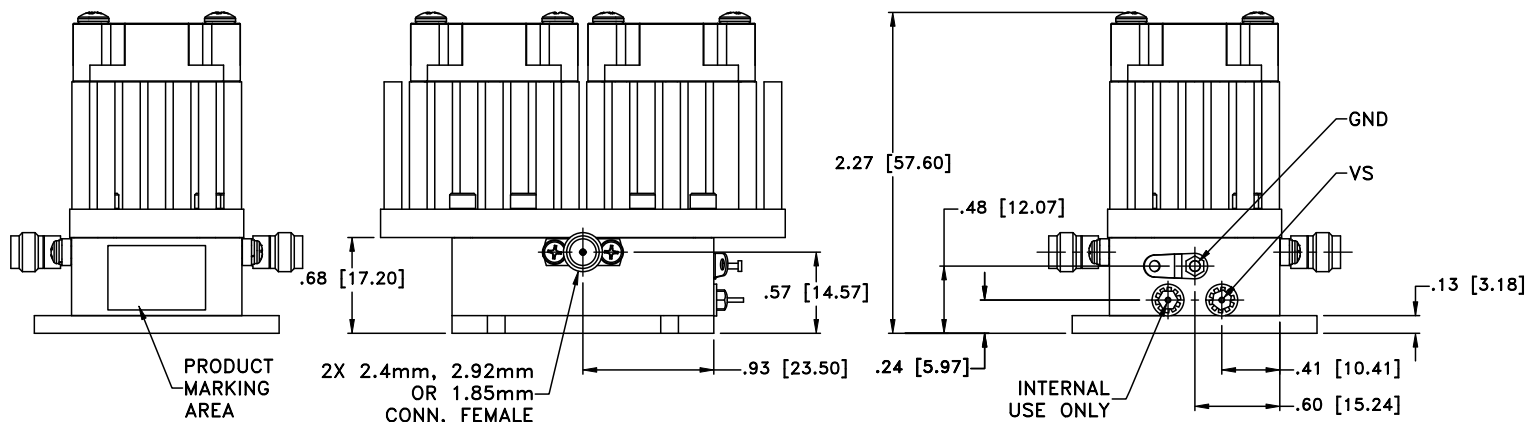
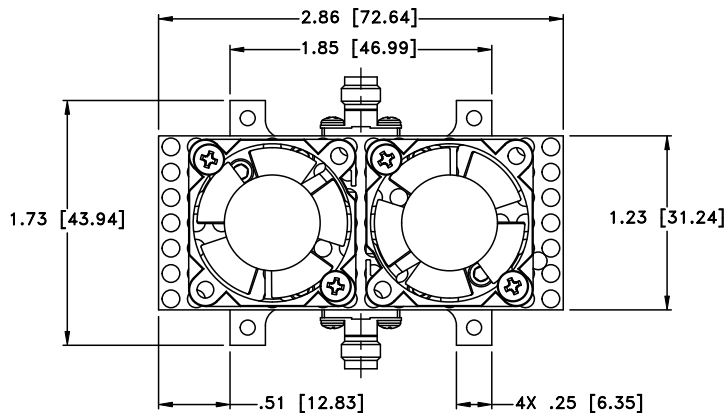

OQWPVKP I'KPHQTOCVKQP'QH'OQFGN'YIVJQWV'JGCVUKPM

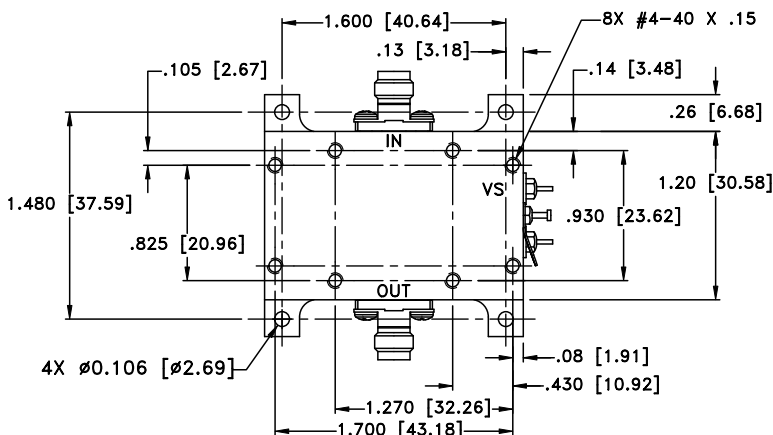

Y V0 Y V0I TCO U'382'i tco u=""Y KJ QWV'J GCVUKPMI TCO U'82'i tco u"

Flo gpukqpu'ctg'lp'pej gu"o o #0Vqrgtcegu<4'Rr0025="5'Rr000237"

Pqvgu<

30 Ecug'o cvgtkn<Cno kpwo 0

40 Ecug'hpkuj <I qif 'r rvpki =

50 J gcvukpmihpkuj <""Drcen'cpqf k g0

60 Tghgt'v'j g'lpf kxf wcnb qf gnf'cvc'uj gg'vht'v'j g'v'r g'qh'epppgevqtu'cxckrdrg0

70 Uj cr g'qh'epppgevqt'hrpi g'o c' 'xct{0



P.O. Box 350166, Brooklyn, New York 11235-0003 (718) 934-4500 Fax (718) 332-4661 For detailed performance specs & shopping online see Mini-Circuits web site

The Design Engineers Search Engine Provides ACTUAL Data Instantly From MINI-CIRCUITS At: www.minicircuits.com



RF/IF MICROWAVE COMPONENTS

All Mini-Circuits products are manufactured under exacting quality assurance and control standards, and are capable of meeting published specifications after being subjected to any or all of the following physical and environmental test.

Specification	Test/Inspection Condition	Reference/Spec
Operating Temperature	-40° to +60° C Baseplate Temp	Individual Model Data Sheet
Storage Temperature	-40° to +85° C Ambient Environment	Individual Model Data Sheet
Burn-in	(DC on) 72 hours at 25°C	----
Thermal Shock	-40° C to +85°C, 100 cycles	Transition time = 5 mins, Dwell time = 30 mins
Vibration	Random Vibration (non-operating)	MIL-STD-883K, Method 2025, Cond. 1A