



COAXIAL

# Medium Power Amplifier

# ZVA-50953G+ ZVA-50953GX+

50Ω 50 to 95 GHz Psat +21dBm 1mm Female

## THE BIG DEAL

- Exceptionally High Frequency
- Flat Gain Response, ±2.0 dB Typ.
- High Psat, +21 dBm Typ.
- Wide DC Operating Voltage, +10 To +15 V
- Over Voltage And Reverse Voltage Protected
- 1mm Coaxial Connectors

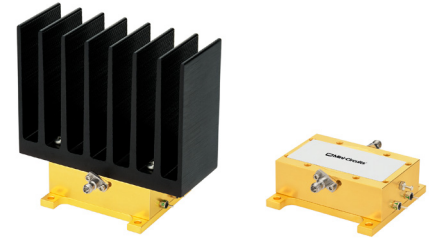

Generic photo used for illustration purposes only

## APPLICATIONS

- Automotive Radar Testing
- 5G-FR2 Millimeter Wave Testing
- Aerospace & Defense
- Test and Measurement
- E-Band Backhaul

## FUNCTIONAL DIAGRAM

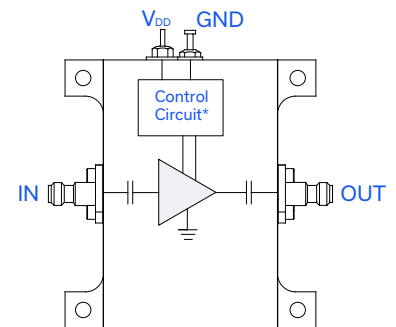

\*Voltage Regulation, over-voltage, reverse voltage, and in-rush current protection circuit

## PRODUCT OVERVIEW

Mini-Circuits' ZVA-50953G+ is a coaxial wideband and flat gain amplifier operating from 50 GHz to 95 GHz. The model operates over a positive supply range of +10 to +15 V, allowing users to choose their desired operating voltage. Internal DC-DC conversion circuitry maintains constant efficiency over the full input voltage range. The amplifier incorporates several DC-protection features such as over-voltage, reverse voltage, and in-rush current protection to protect from damage in case of unexpected spikes in voltage during operation. The high frequency operation combined with high gain and medium output power makes this amplifier an ideal choice for automotive radar applications and 5G testing in millimeter wave bands.

## KEY FEATURES

Features	Advantages
Wideband amplifier, 50 to 95 GHz	A single amplifier serves the need for multiple applications including automotive radar and 5G millimeter wave testing.
Wide DC Operating Voltage, +10 To +15 V	The device can operate from +10 to +15 V, maintaining constant DC power consumption with no effect on RF performance and facilitating ease of use in test setups with existing established voltage supplies.
DC Protection <ul style="list-style-type: none"> <li>• Over-voltage</li> <li>• Reverse voltage</li> <li>• In-rush current</li> </ul>	The internal DC circuitry allows the amplifier to be protected from external mishandling or unexpected spikes in voltage that could lead to catastrophic failures in the field.





COAXIAL

# Medium Power Amplifier

## ZVA-50953G+ ZVA-50953GX+

50Ω 50 to 95 GHz Psat +21dBm 1mm Female

### ELECTRICAL SPECIFICATIONS AT +25 °C BASEPLATE, $V_{DD} = +10V$

Parameter	Condition (GHz)	Min.	Typ.	Max.	Units
Frequency Range	-	50	-	95	GHz
Gain	50 - 90	25	28.5	-	
	90 - 95	23	27.5	-	
Output Power at 1 dB Compression (P1dB)	50 - 55	+15.5	+17.5	-	dBm
	55 - 90	+14	+16.5	-	
	90 - 95	+15.5	+18	-	
Output Power at Saturation ( $P_{SAT}$ ) <sup>1</sup>	50 - 55	+19.5	+22	-	dBm
	55 - 90	+18	+20.5	-	
	90 - 95	+19	+21	-	
Input Return Loss	50 - 95	-	12	-	dB
Output Return Loss	50 - 95	-	12	-	dB
DC Supply Voltage ( $V_{DD}$ )	-	+10	-	+15	V
DC Current at $V_{DD} = +10V$	-	-	370	650 <sup>2</sup>	mA

1. At Psat, Pout changes less than 0.1 dB for a 1 dB change in Pin

2. Max DC Current at Psat. DC current increases as amplifier is driven into compression.



COAXIAL

# Medium Power Amplifier

## ZVA-50953G+ ZVA-50953GX+

50Ω 50 to 95 GHz P<sub>sat</sub> +21dBm 1mm Female

### TYPICAL PERFORMANCE GRAPHS

ZVA-50953G+  
GAIN

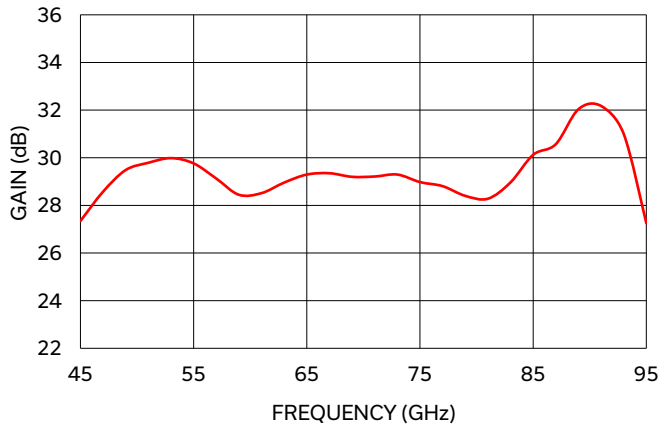

ZVA-50953G+  
RETURN LOSS

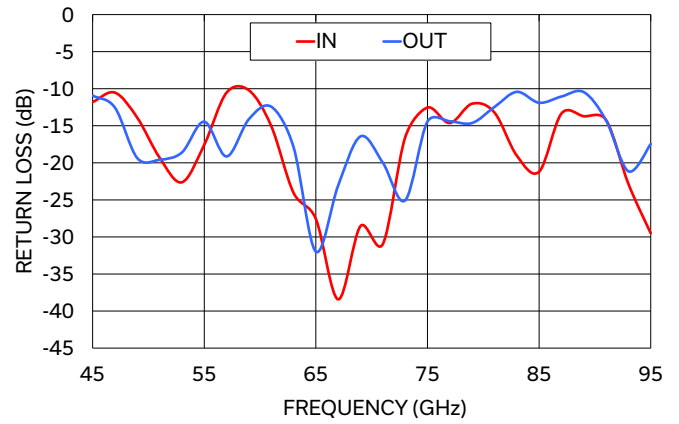

ZVA-50953G+  
OUTPUT POWER

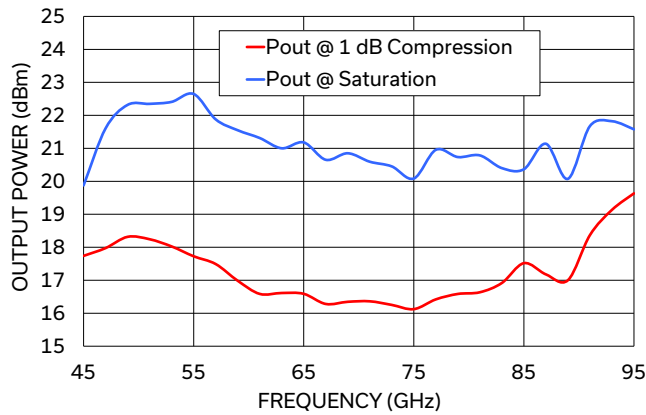



COAXIAL

# Medium Power Amplifier

## ZVA-50953G+ ZVA-50953GX+

50Ω 50 to 95 GHz Psat +21dBm 1mm Female

### ABSOLUTE MAXIMUM RATINGS<sup>3</sup>

Parameter	Ratings		
Operating Temperature	ZVA-50953G+	-40 °C to +50°C	Ambient
	ZVA-50953GX+	-40 °C to +60°C	Baseplate
Storage Temperature	-40 °C to +85°C		
Total Power Dissipation	6.5 W		
RF Input Power <sup>4</sup> (CW)	+15 dBm		
DC Operating Voltage (V <sub>DD</sub> )	+16 V		
Export Info	EECN #3A001.B.4 This item will require an export license to certain countries		

3. Continuous operation is not recommended at these extremes. Permanent damage may occur if any of these limits are exceeded.

4. Specified under matched load to 50 ohms.

### DETERMINING MAXIMUM THERMAL RESISTANCE OF USERS' EXTERNAL HEAT SINK

<b>MAXIMUM THERMAL RESISTANCE</b>	=	$\frac{\text{MAXIMUM OPERATING CASE TEMP} - \text{MAXIMUM USER AMBIENT TEMP}}{\text{POWER DISSIPATION}}$
<b>Example:</b>		<p>MAXIMUM OPERATING CASE TEMP = +50 °C (CHECK MAXIMUM RATINGS TABLE FOR THIS VALUE)</p> <p>MAXIMUM USER AMBIENT TEMP = +30 °C (USER DEFINED)</p> <p>POWER DISSIPATION = 10 WATTS (CHECK MAXIMUM RATINGS TABLE FOR THIS VALUE)</p> <p>THEN MAXIMUM ALLOWABLE THERMAL RESISTANCE = 2 °C/W</p>





COAXIAL

# Medium Power Amplifier

## ZVA-50953G+ ZVA-50953GX+

50Ω 50 to 95 GHz Psat +21dBm 1mm Female

### CASE STYLE DRAWING WITH HEATSINK (ZVA-50953G+)

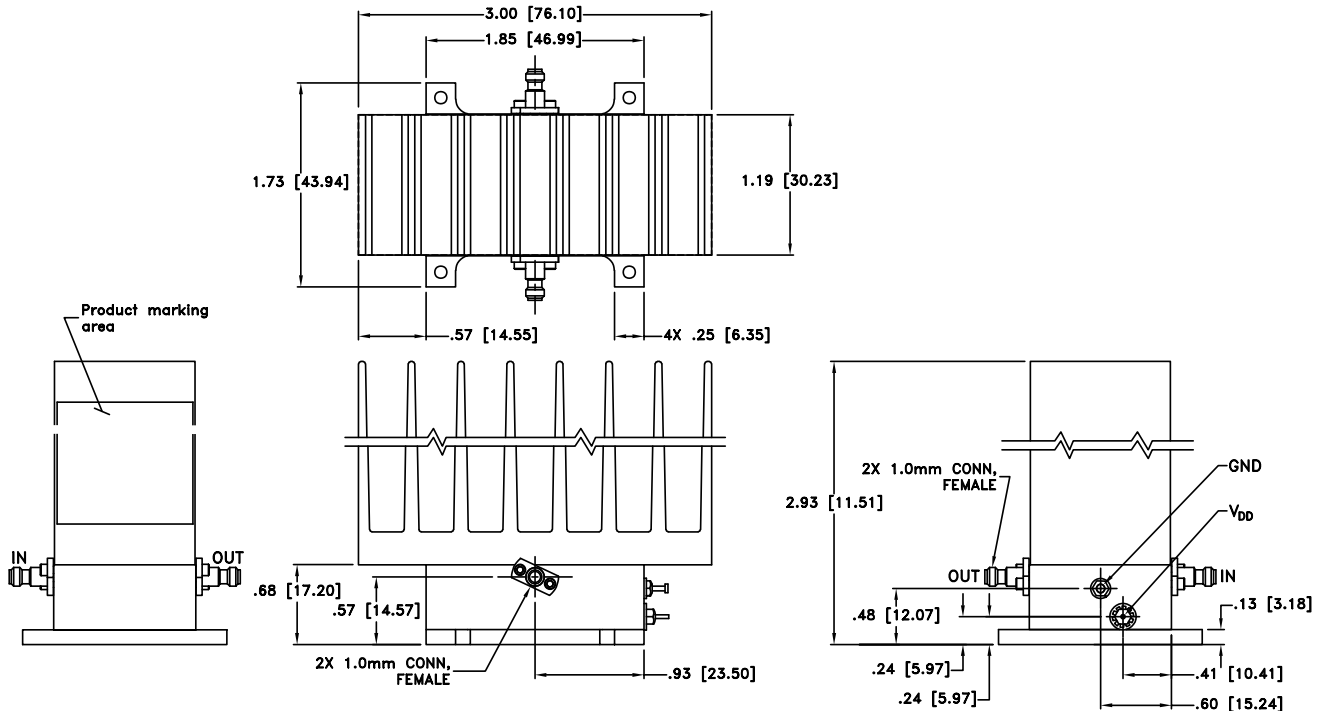

### CASE STYLE DRAWING WITHOUT HEATSINK (ZVA-50953GX+)

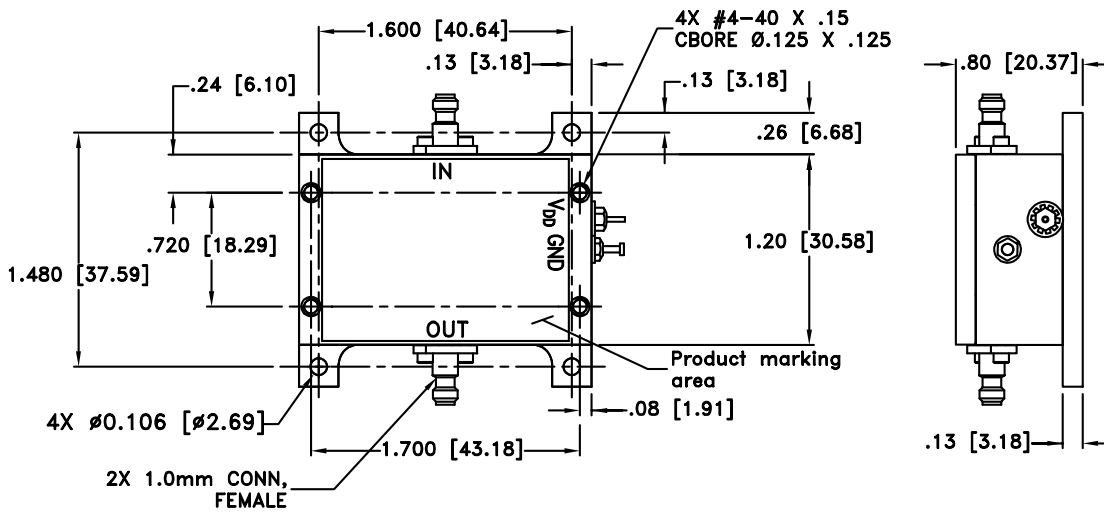

WT. 160 grams; Without Heatsink 60 grams  
Dimensions are in inches [mm]. Tolerances 2PI ± 0.15 Inches





COAXIAL

# Medium Power Amplifier

## ZVA-50953G+ ZVA-50953GX+

50Ω 50 to 95 GHz Psat +21dBm 1mm Female

### ADDITIONAL INFORMATION IS AVAILABLE ON OUR DASHBOARD.

Performance Data	Data Table
	Swept Graphs
	S-Parameter (S2P Files) Data Set (.zip file)
RoHs Status	Compliant
Environmental Ratings	ENV130
Export Information	EECN #3A001.B.4 This item will require an export license when shipped to certain countries

### ORDERING INFORMATION

Model No. Links	<a href="#">ZVA-50953G+</a>	<a href="#">ZVA-50953GX+</a>
Option	With heatsink	Without heatsink
Product Marking	ZVA-50953G+	ZVA-50953GX+
Case Style	WC3071-5	
Connector	1mm (Female)	

#### NOTES

- A. Performance and quality attributes and conditions not expressly stated in this specification document are intended to be excluded and do not form a part of this specification document.
- B. Electrical specifications and performance data contained in this specification document are based on Mini-Circuit's applicable established test performance criteria and measurement instructions.
- C. The parts covered by this specification document are subject to Mini-Circuits standard limited warranty and terms and conditions (collectively, "Standard Terms"); Purchasers of this part are entitled to the rights and benefits contained therein. For a full statement of the standard terms and the exclusive rights and remedies thereunder, please visit Mini-Circuits' website at [www.minicircuits.com/terms/viewterm.html](http://www.minicircuits.com/terms/viewterm.html)



<i>Typical Performance Data</i>					
FREQUENCY (GHz)	GAIN (dB) 10V	RETURN LOSS (dB)		Pout @ 1 dB COMPRESSION (dBm) 10V	Pout at SATURATION (dBm) 10V
		IN 10V	OUT 10V		
45.0	27.35	11.8	10.9	17.7	19.88
47.0	28.58	10.5	12.6	18.0	21.61
49.0	29.48	13.9	19.4	18.3	22.32
51.0	29.79	19.3	19.6	18.2	22.35
53.0	29.98	22.6	18.6	18.0	22.41
55.0	29.76	17.6	14.4	17.7	22.65
57.0	29.13	10.5	19.1	17.5	21.88
59.0	28.45	10.2	14.1	17.0	21.55
61.0	28.51	15.0	12.4	16.6	21.31
63.0	28.96	24.0	17.9	16.6	21.00
65.0	29.29	27.6	32.0	16.6	21.18
67.0	29.35	38.4	23.1	16.3	20.65
69.0	29.20	28.5	16.4	16.3	20.85
71.0	29.21	31.0	20.0	16.4	20.59
73.0	29.29	16.6	25.1	16.3	20.45
75.0	28.98	12.5	14.4	16.1	20.08
77.0	28.81	14.6	14.4	16.4	20.95
79.0	28.40	12.0	14.6	16.6	20.74
81.0	28.28	13.2	12.5	16.6	20.79
83.0	28.96	19.0	10.4	16.9	20.40
85.0	30.12	21.2	11.9	17.5	20.37
87.0	30.57	13.4	11.1	17.2	21.14
89.0	32.04	13.7	10.5	17.0	20.07
91.0	32.17	14.2	14.3	18.4	21.67
93.0	31.00	22.8	21.1	19.1	21.82
95.0	27.25	29.5	17.5	19.6	21.58

## Typical Performance Curves

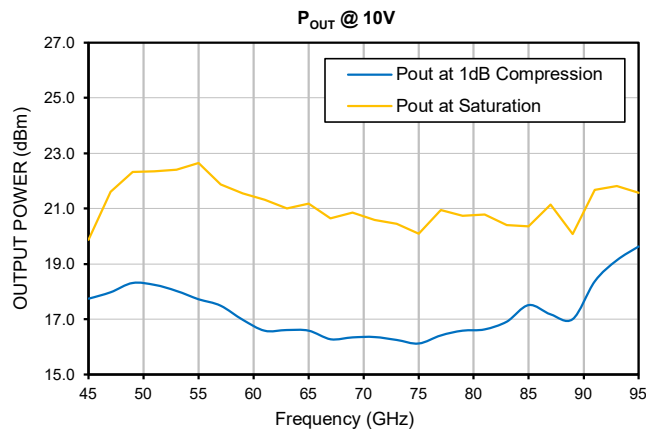
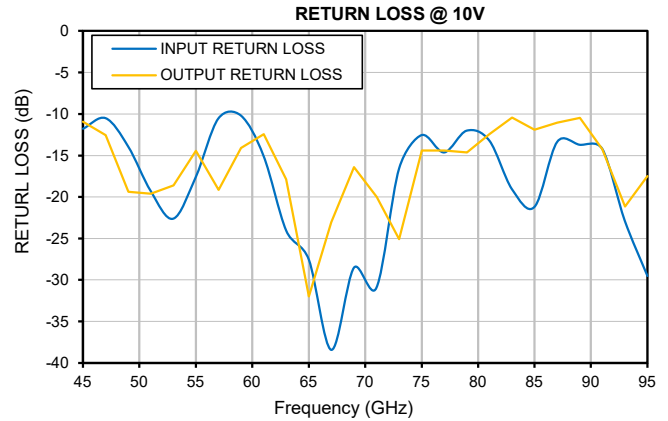
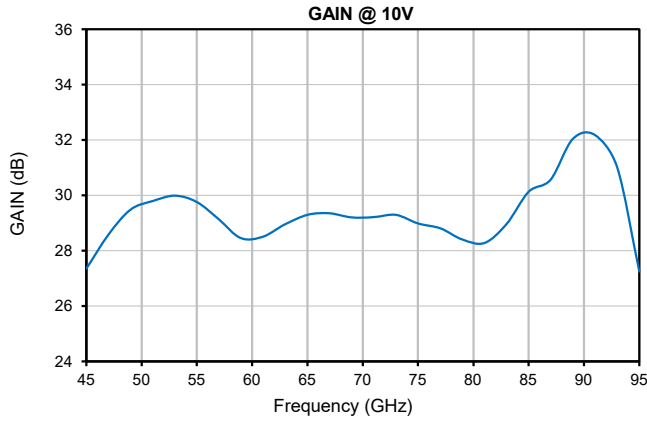



## Outline Dimensions

WC3071-5

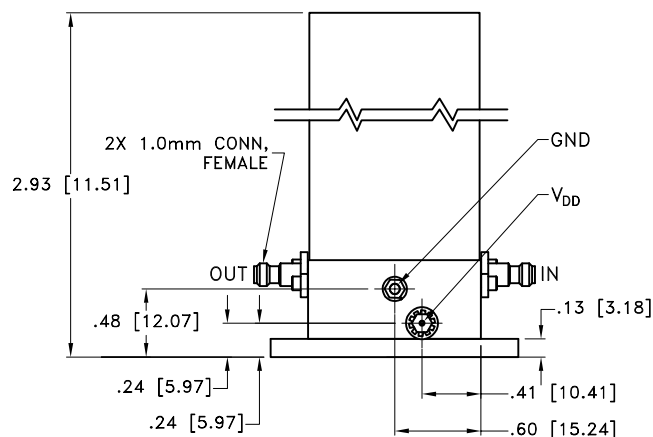
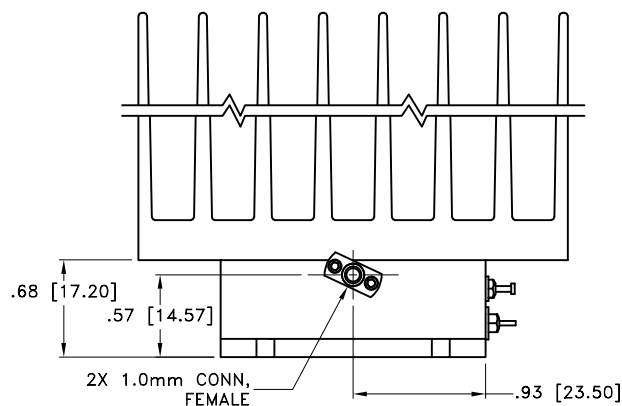
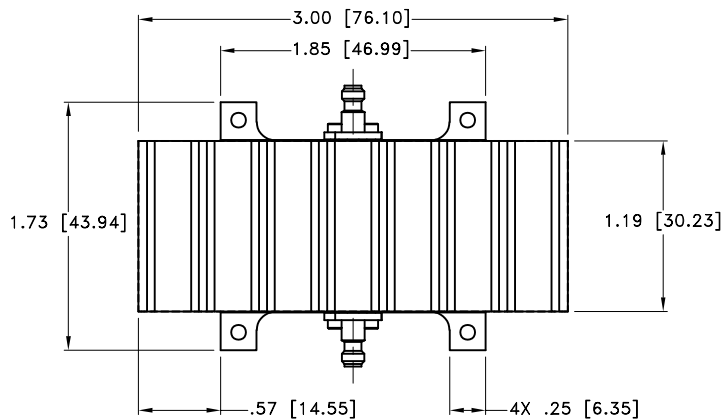

### MOUNTING INFORMATION OF MODEL WITHOUT HEATSINK

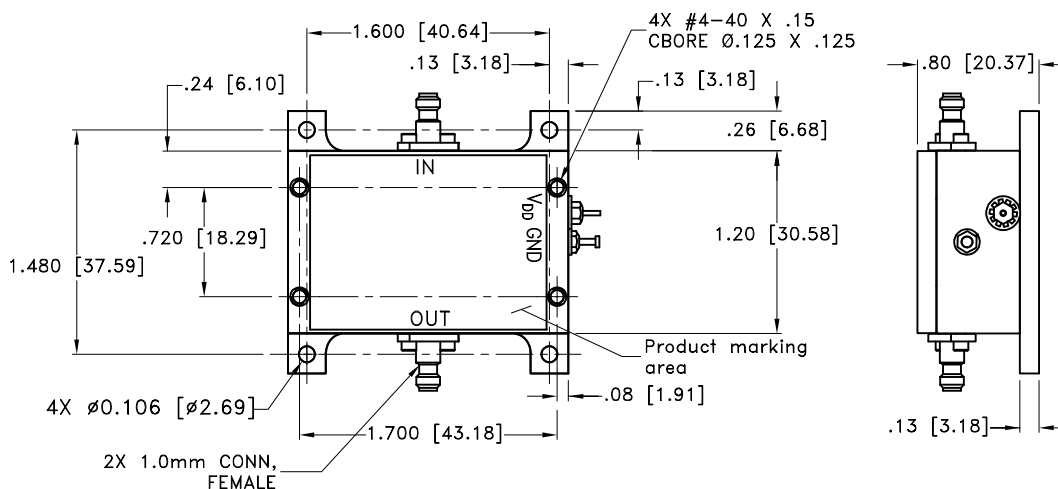

WT. WT. GRAMS 160 grams; WITHOUT HEATSINK GRAMS 60 grams

Dimensions are in inches [mm]. Tolerances: 2 Pl. ±.03; 3 Pl. ±.015 Inches

#### Notes:

1. Case material: Aluminum.
2. Case finish: Gold plating;
3. Heat sink finish: Black anodize.
4. Refer to the individual model data sheet for the type of connectors available.
5. Shape of connector flange may vary.



P.O. Box 350166, Brooklyn, New York 11235-0003 (718) 934-4500 Fax (718) 332-4661 For detailed performance specs & shopping online see Mini-Circuits web site



The Design Engineers Search Engine Provides ACTUAL Data Instantly From MINI-CIRCUITS At: [www.minicircuits.com](http://www.minicircuits.com)

RF/IF MICROWAVE COMPONENTS



All Mini-Circuits products are manufactured under exacting quality assurance and control standards, and are capable of meeting published specifications after being subjected to any or all of the following physical and environmental test.

<b>Specification</b>	<b>Test/Inspection Condition</b>	<b>Reference/Spec</b>
Operating Temperature	-40° to +60° C Baseplate Temp	Individual Model Data Sheet
Storage Temperature	-40° to +85° C Ambient Environment	Individual Model Data Sheet
Burn-in	(DC on) 72 hours at 25°C	----
Thermal Shock	-40° C to +85°C, 100 cycles	Transition time = 5 mins, Dwell time = 30 mins
Vibration	Random Vibration (non-operating)	MIL-STD-883K, Method 2025, Cond. 1A