



COAXIAL

Medium Power Amplifier

ZVA-40703G+ ZVA-40703GX+

50Ω 40 to 70 GHz P_{SAT} +24 dBm 1.85mm Female

THE BIG DEAL

- Exceptionally High Frequency
- Flat Gain Response, ±2.5 dB
- High P_{SAT}, +24 dBm Typ.
- Wide DC Operating Voltage, +10 To +15 V
- Over Voltage and Reverse Voltage Protected

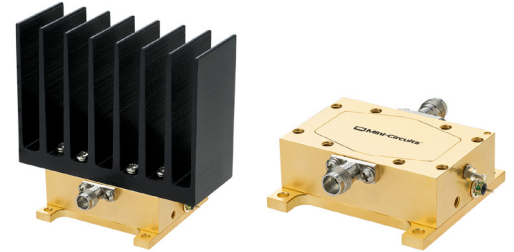

Generic photo used for illustration purposes only

APPLICATIONS

- 5G-FR2 Millimeter Wave Testing
- Aerospace & Defense
- Test and Measurement
- Broadband Telecom
- Q- and V-Band SATCOM
- IEEE 802.11.ad WiGig

FUNCTIONAL DIAGRAM

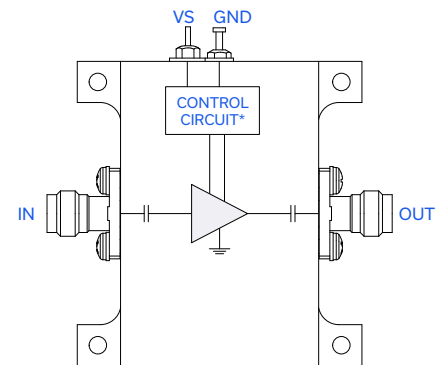

*Voltage Regulation, over-voltage, reverse voltage, and in-rush current protection circuit

PRODUCT OVERVIEW

Mini-Circuits' ZVA-40703G+ is a coaxial wideband and flat gain amplifier operating from 40 GHz to 70 GHz. The model operates over a positive supply range of +10 to +15 V, allowing users to choose their desired operating voltage. Internal DC-DC conversion circuitry maintains consistent efficiency over the full input voltage range. The amplifier incorporates several DC-protection features such as over-voltage, reverse voltage, and in-rush current protection to protect the amplifier from damage in case of unexpected spikes in voltage during operation. The high frequency operation combined with high gain and medium output power makes this amplifier an ideal choice for 5G testing in millimeter wave bands.

KEY FEATURES

Feature	Advantages
Wideband amplifier, 40 to 70 GHz	A single broadband amplifier covers multiple 5G mmWave bands up to 70 GHz, as well as Q- and V-Band SATCOM applications.
High Saturated Output Power, 24 dBm Typ.	1/4 W typical saturated output power makes this amplifier an ideal driver in test bench applications, semiconductor chipset testing, as an LO driver for mixers and more.
Wide DC Operating Voltage, +10 To +15 V	The device can operate from +10 to +15 V, maintaining consistent DC power consumption with no effect on RF performance and facilitating ease of use in test setups with existing established voltage supplies.
DC Protection <ul style="list-style-type: none"> • Over-voltage • Reverse voltage • In-rush current 	The internal DC circuitry allows the amplifier to be protected from external mishandling or unexpected spikes in voltage that could lead to catastrophic failures in the field.





COAXIAL

Medium Power Amplifier

ZVA-40703G+ ZVA-40703GX+



50Ω 40 to 70 GHz P_{SAT} +24 dBm 1.85mm Female

ELECTRICAL SPECIFICATIONS AT +25 °C BASEPLATE

Parameter	Condition (GHz)	Min.	Typ.	Max.	Units
Frequency Range	-	40		70	GHz
Gain	40 - 65	31.0	34.0	-	dB
	65 - 70	28.5	33.0	-	
Output Power at 1dB compression (P1dB)	40 - 65	+21.0	+22.5	-	dBm
	65 - 70	+20.0	+21.5	-	
Saturated Output Power (P _{SAT}) ¹	40 - 65	+22.0	+24.0	-	dBm
	65 - 70	+21.0	+23.0	-	
Output IP3 (Output Power = +14 dBm/tone)	40 - 70	-	+30	-	dBm
Input Return Loss	40 - 70	-	13	-	dB
Output Return Loss	40 - 70	-	13	-	dB
Noise Figure	40 - 70	-	6.5	-	dB
DC Supply Voltage (VS)	-	+10	-	+15	V
DC Current at VS = +10V	-	—	470	900 ²	mA

1. At P_{SAT}, P_{OUT} changes less than 0.1 dB for a 1 dB change in P_{IN}

2. Typical current measured under small signal conditions. Max DC current measured at P_{SAT}. DC current increases as amplifier is driven into compression.





COAXIAL

Medium Power Amplifier

ZVA-40703G+ ZVA-40703GX+

Mini-Circuits

50Ω 40 to 70 GHz P_{SAT} +24 dBm 1.85mm Female

TYPICAL PERFORMANCE GRAPHS

GAIN

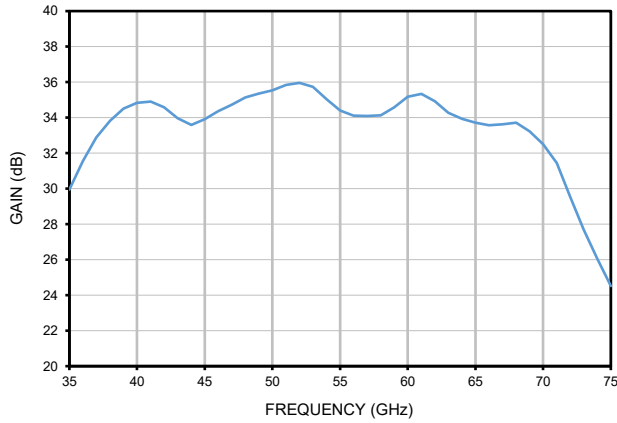

ACTIVE DIRECTIVITY

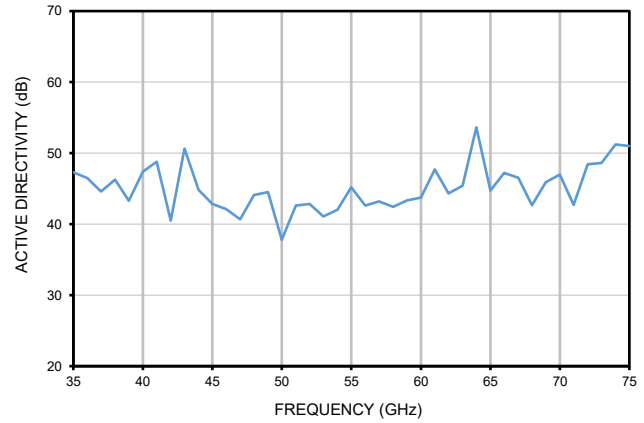

RETURN LOSS

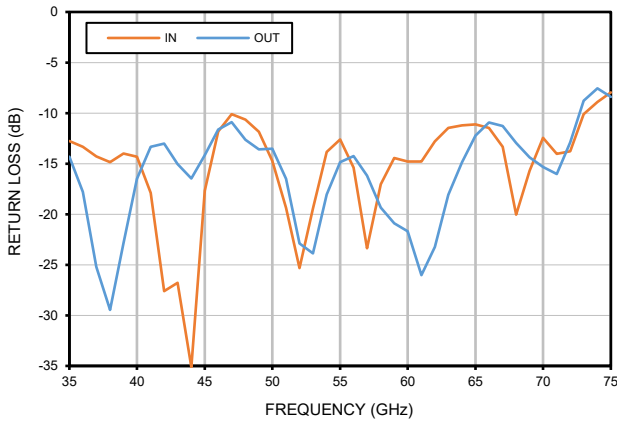

OUTPUT POWER

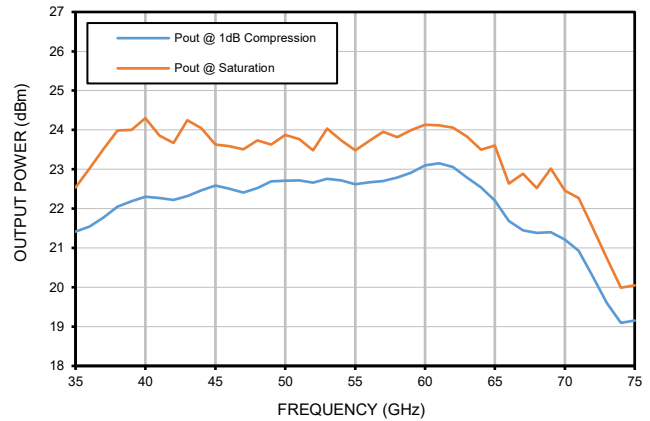

NOISE FIGURE

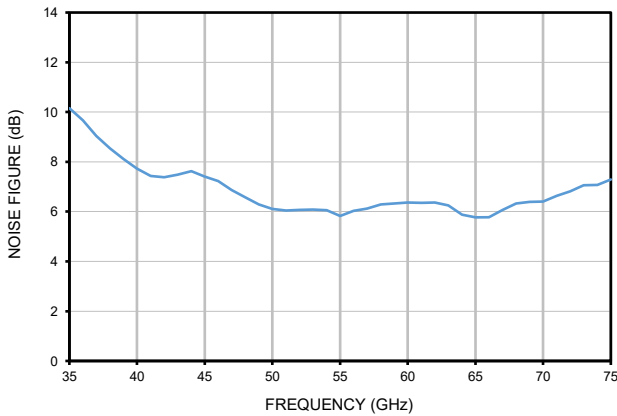

OIP3

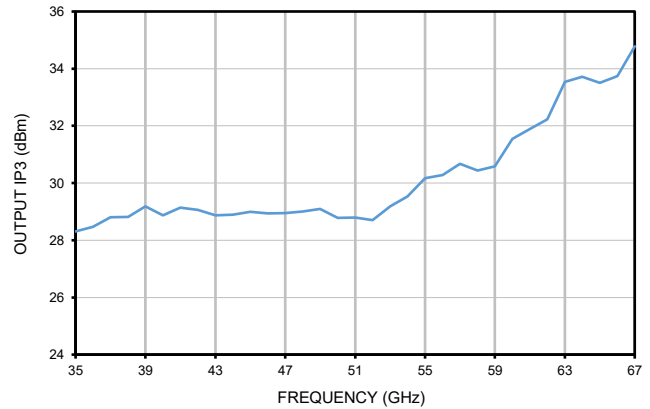



COAXIAL

Medium Power Amplifier

ZVA-40703G+ ZVA-40703GX+

Mini-Circuits

50Ω 40 to 70 GHz P_{SAT} +24 dBm 1.85mm Female

ABSOLUTE MAXIMUM RATINGS³

Parameter	Ratings
Operating Temperature	ZVA-40703G+ -40 °C to +50 °C Ambient
	ZVA-40703GX+ -40 °C to +60 °C Baseplate
Storage Temperature	-40 °C to +85 °C
Total Power Dissipation	9.5 W
RF Input Power ⁴ (CW)	+1 dBm
DC Operating Voltage	+16 V

3. Continuous operation is not recommended at these extremes. Permanent damage may occur if any of these limits are exceeded.

4. Specified under matched load to 50 ohms.

DETERMINING MAXIMUM THERMAL RESISTANCE OF USERS' EXTERNAL HEAT SINK

$\text{MAXIMUM THERMAL RESISTANCE}$	$= \frac{\text{MAXIMUM OPERATING CASE TEMP} - \text{MAXIMUM USER AMBIENT TEMP}}{\text{POWER DISSIPATION}}$
Example:	<p>MAXIMUM OPERATING CASE TEMP = 60 °C (CHECK MAXIMUM RATINGS TABLE FOR THIS VALUE)</p> <p>MAXIMUM USER AMBIENT TEMP = 30 °C (USER DEFINED)</p> <p>POWER DISSIPATION = 9.5 WATTS (CHECK MAXIMUM RATINGS TABLE FOR THIS VALUE)</p> <p>THEN MAXIMUM ALLOWABLE THERMAL RESISTANCE = 3.1 °C/W</p>





COAXIAL

Medium Power Amplifier

ZVA-40703G+ ZVA-40703GX+

Mini-Circuits

50Ω 40 to 70 GHz P_{SAT} +24 dBm 1.85mm Female

CASE STYLE DRAWING WITH HEATSINK (ZVA-40703G+)

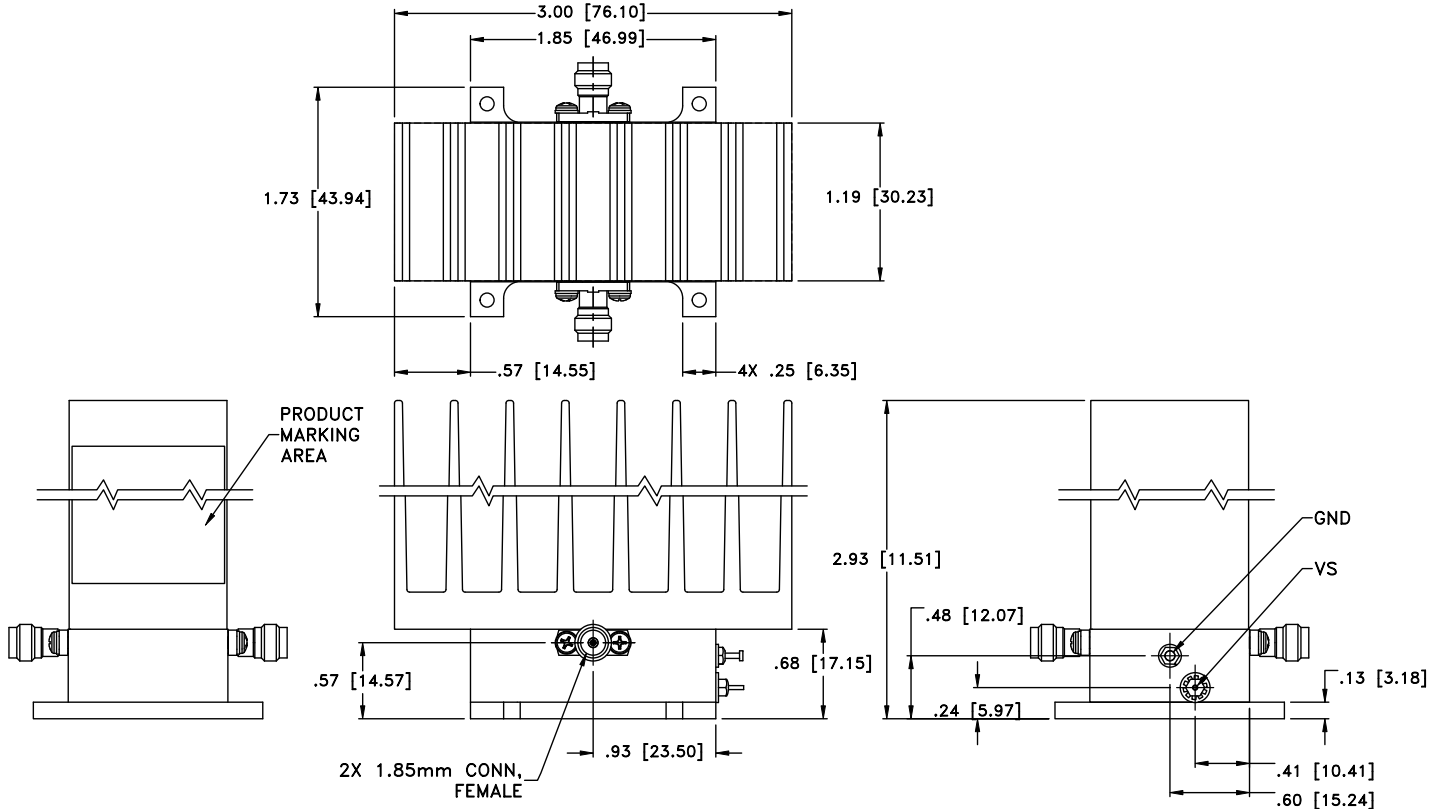

CASE STYLE DRAWING WITHOUT HEATSINK (ZVA-40703GX+)

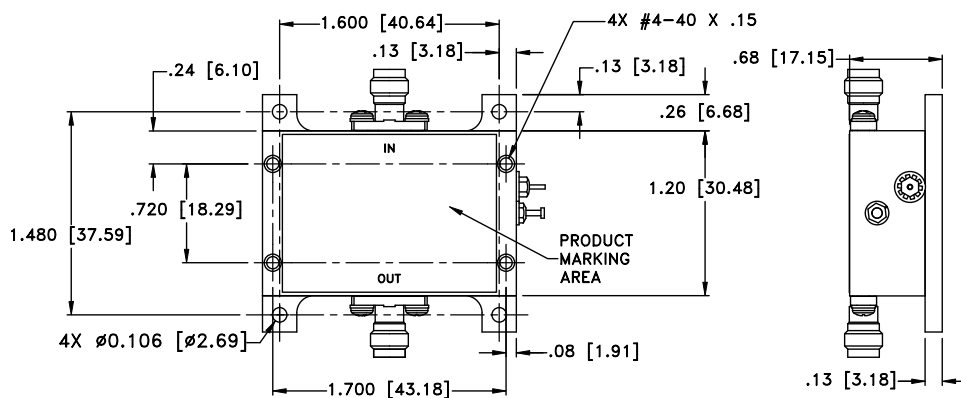

Weight: 160 grams; without heatsink: 60 grams

Dimensions are in inches [mm]. Tolerances: 2 Pl. ±.03; 3 Pl. ±.015 Inches





COAXIAL

Medium Power Amplifier

ZVA-40703G+ ZVA-40703GX+



50Ω 40 to 70 GHz P_{SAT} +24 dBm 1.85mm Female

ADDITIONAL INFORMATION IS AVAILABLE ON OUR DASHBOARD.

Performance Data	Data Table
	Swept Graphs
	S-Parameter (S2P Files) Data Set (.zip file)
RoHs Status	Compliant
Environmental Ratings	ENV130
Export Information	EECN #3A001.B.4 This item will require an export license when shipped to certain countries

ORDERING INFORMATION

Model No. Links	ZVA-40703G+	ZVA-40703GX+
Option	With heatsink	Without heatsink
Product Marking	ZVA-40703G+	ZVA-40703GX+
Case Style	WC3071-7	
Connector	1.85 mm (Female)	

- NOTES**
- A. Performance and quality attributes and conditions not expressly stated in this specification document are intended to be excluded and do not form a part of this specification document.
 - B. Electrical specifications and performance data contained in this specification document are based on Mini-Circuit's applicable established test performance criteria and measurement instructions.
 - C. The parts covered by this specification document are subject to Mini-Circuits standard limited warranty and terms and conditions (collectively, "Standard Terms"); Purchasers of this part are entitled to the rights and benefits contained therein. For a full statement of the standard. Terms and the exclusive rights and remedies thereunder, please visit Mini-Circuits' website at www.minicircuits.com/MCLStore/terms.jsp



Typical Performance Data

FREQUENCY (GHz)	GAIN (dB)	ACTIVE DIRECTIVITY (dB)	RETURN LOSS (dB)		Pout @ 1 dB COMPRESSION (dBm)	Pout at SATURATION (dBm)	NOISE FIGURE (dB)	OIP3 (dBm)
			IN	OUT				
35.0	29.96	47.30	12.77	14.30	21.4	22.5	10.2	28.31
36.0	31.54	46.50	13.34	17.79	21.5	23.0	9.7	28.47
37.0	32.89	44.61	14.29	25.19	21.8	23.5	9.0	28.80
38.0	33.83	46.28	14.85	29.46	22.0	24.0	8.5	28.82
39.0	34.50	43.30	13.99	22.87	22.2	24.0	8.1	29.18
40.0	34.83	47.38	14.31	16.50	22.3	24.3	7.7	28.87
41.0	34.90	48.78	17.90	13.35	22.3	23.9	7.4	29.14
42.0	34.59	40.49	27.61	13.02	22.2	23.7	7.4	29.06
43.0	33.97	50.66	26.77	15.04	22.3	24.2	7.5	28.87
44.0	33.59	44.84	35.11	16.46	22.5	24.0	7.6	28.90
45.0	33.91	42.85	17.66	14.14	22.6	23.6	7.4	29.00
46.0	34.37	42.10	11.81	11.62	22.5	23.6	7.2	28.94
47.0	34.72	40.67	10.12	10.89	22.4	23.5	6.9	28.95
48.0	35.14	44.09	10.65	12.64	22.5	23.7	6.6	29.00
49.0	35.35	44.53	11.84	13.59	22.7	23.6	6.3	29.09
50.0	35.53	37.80	14.73	13.51	22.7	23.9	6.1	28.78
51.0	35.84	42.64	19.38	16.51	22.7	23.8	6.0	28.80
52.0	35.96	42.86	25.32	22.88	22.7	23.5	6.1	28.71
53.0	35.74	41.08	19.45	23.86	22.8	24.0	6.1	29.18
54.0	35.03	42.02	13.83	18.03	22.7	23.7	6.1	29.53
55.0	34.41	45.20	12.62	14.85	22.6	23.5	5.8	30.17
56.0	34.11	42.60	15.38	14.25	22.7	23.7	6.0	30.28
57.0	34.10	43.21	23.38	16.18	22.7	24.0	6.1	30.68
58.0	34.13	42.45	17.05	19.33	22.8	23.8	6.3	30.44
59.0	34.57	43.33	14.45	20.91	22.9	24.0	6.3	30.58
60.0	35.17	43.76	14.80	21.70	23.1	24.1	6.4	31.54
61.0	35.34	47.70	14.79	26.01	23.2	24.1	6.4	31.89
62.0	34.92	44.31	12.79	23.25	23.1	24.1	6.4	32.23
63.0	34.27	45.41	11.46	18.08	22.8	23.8	6.2	33.53
64.0	33.93	53.63	11.20	14.84	22.5	23.5	5.9	33.72
65.0	33.72	44.73	11.11	12.22	22.2	23.6	5.8	33.51
66.0	33.58	47.23	11.46	10.92	21.7	22.6	5.8	33.75
67.0	33.63	46.53	13.33	11.27	21.4	22.9	6.1	34.78
68.0	33.72	42.64	20.04	12.95	21.4	22.5	6.3	-
69.0	33.23	45.91	15.69	14.37	21.4	23.0	6.4	-
70.0	32.51	47.01	12.44	15.32	21.2	22.5	6.4	-
71.0	31.45	42.69	14.03	16.02	20.9	22.3	6.6	-
72.0	29.53	48.45	13.79	12.88	20.3	21.5	6.8	-
73.0	27.69	48.61	10.09	8.77	19.6	20.7	7.1	-
74.0	26.03	51.22	8.89	7.55	19.1	20.0	7.1	-
75.0	24.52	50.98	7.96	8.38	19.2	20.0	7.3	-

Coaxial Amplifier

Typical Performance Curves

ZVA-40703G(X)+

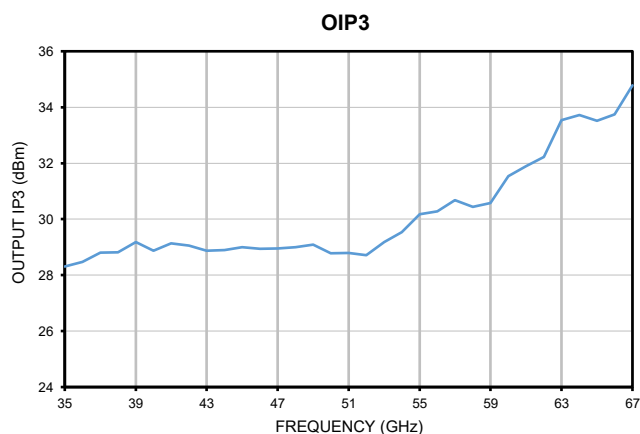
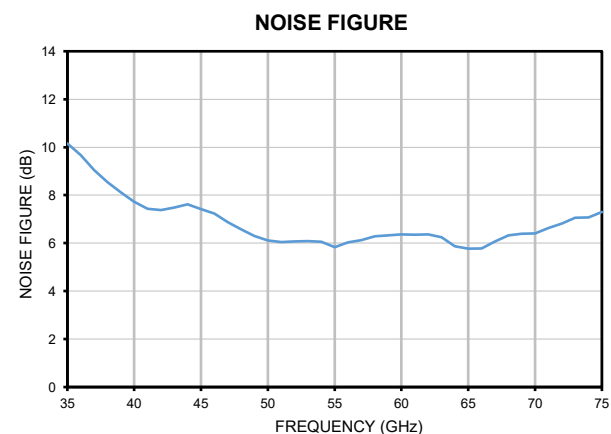
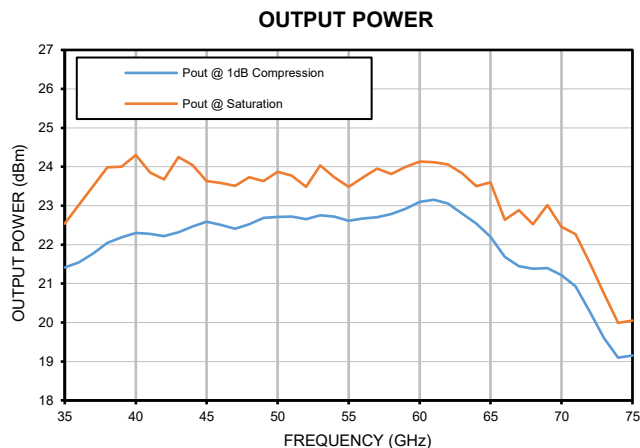
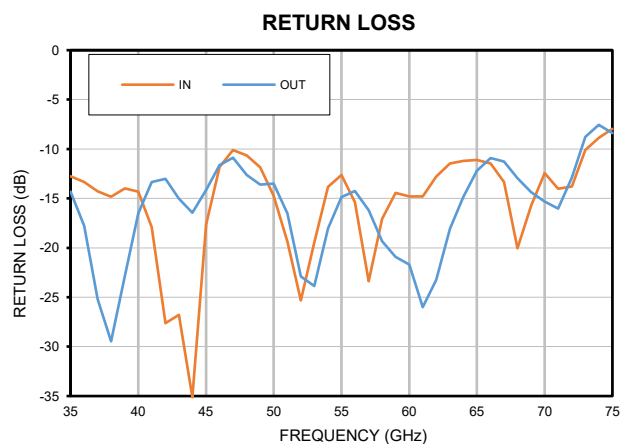
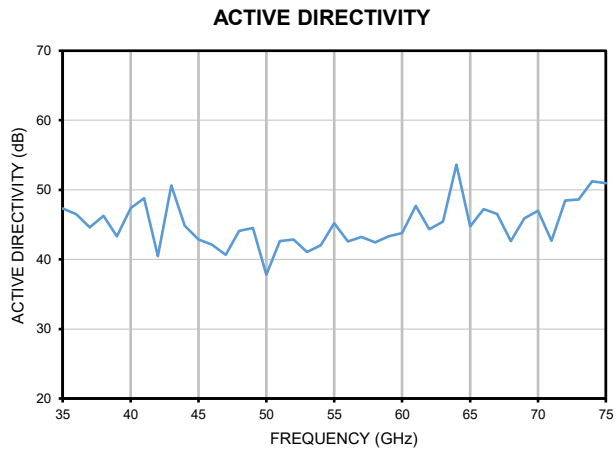
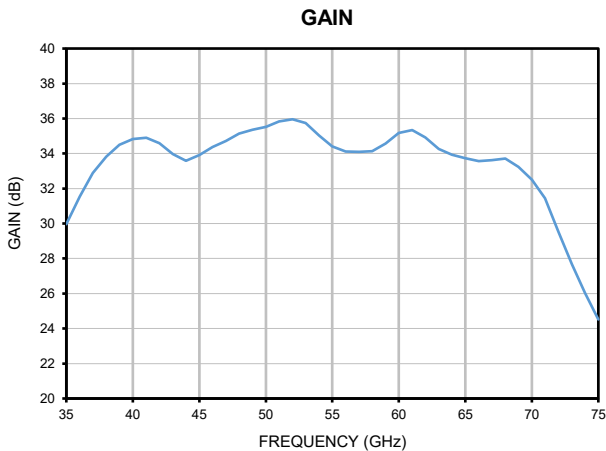

Outline Dimensions

WC3071-7

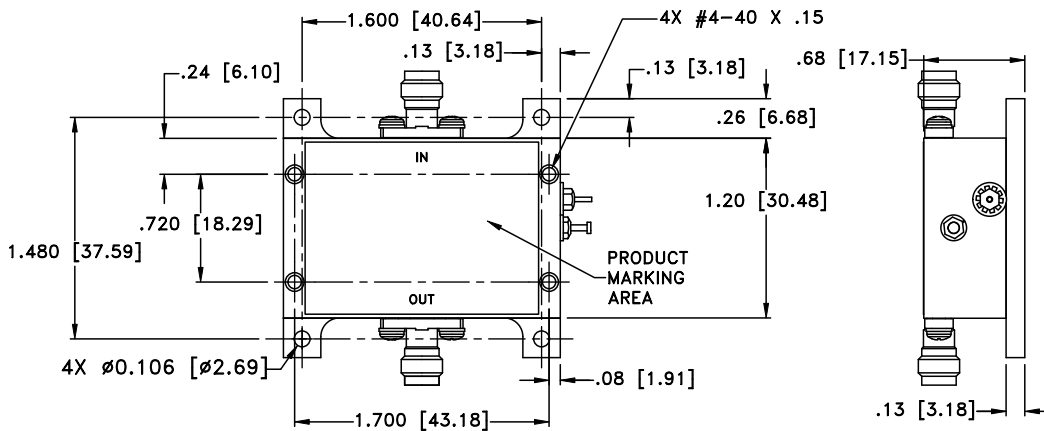
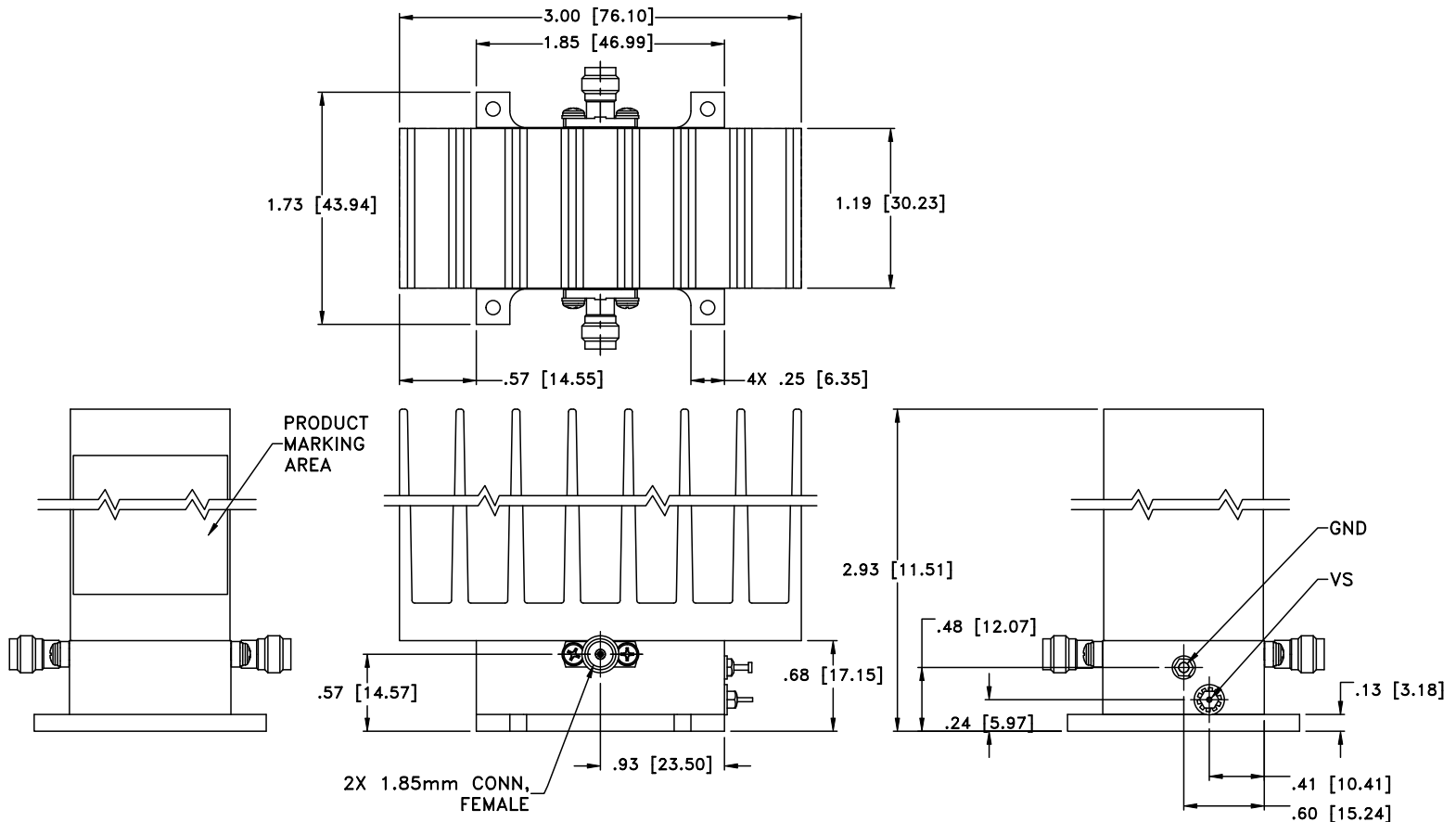

WT. WT. GRAMS 160 grams; WITHOUT HEATSINK GRAMS 60 grams

Dimensions are in inches (mm). Tolerances: 2 Pl.±.03; 3 Pl. ±.015

Notes:

1. Case material: Aluminum.
2. Case finish: Gold plating;
3. Heat sink finish: Black anodize.
4. Refer to the individual model data sheet for the type of connectors available.
5. Shape of connector flange may vary.

Mini-Circuits®
ISO 9001 ISO 14001 CERTIFIED

ALL NEW
minicircuits.com

P.O. Box 350166, Brooklyn, New York 11235-0003 (718) 934-4500 Fax (718) 332-4661 For detailed performance specs & shopping online see Mini-Circuits web site



The Design Engineers Search Engine Provides ACTUAL Data Instantly From MINI-CIRCUITS At: www.minicircuits.com

RF/IF MICROWAVE COMPONENTS

All Mini-Circuits products are manufactured under exacting quality assurance and control standards, and are capable of meeting published specifications after being subjected to any or all of the following physical and environmental test.

Specification	Test/Inspection Condition	Reference/Spec
Operating Temperature	-40° to +60° C Baseplate Temp	Individual Model Data Sheet
Storage Temperature	-40° to +85° C Ambient Environment	Individual Model Data Sheet
Burn-in	(DC on) 72 hours at 25°C	----
Thermal Shock	-40° C to +85°C, 100 cycles	Transition time = 5 mins, Dwell time = 30 mins
Vibration	Random Vibration (non-operating)	MIL-STD-883K, Method 2025, Cond. 1A