



MEDIUM POWER, WIDEBAND

# High-Frequency Amplifier

## ZVA-35703+ ZVA-35703X+

50Ω 35 to 71 GHz

### THE BIG DEAL

- High gain 17.5 dB typ. over the entire operating band
- Excellent gain flatness, ±1.5 dB typ.
- High Psat = 21 dBm typ.
- Adjustable DC voltage, +10 to +15 V

### APPLICATIONS

- Automotive tests
- Radar/Sensing
- 5G FR2+ bands (Ka-band, Q-band, V-band, E-band)
- SATCOM
- Wireless Infrastructure
- IEEE 802.11.ad WiGig

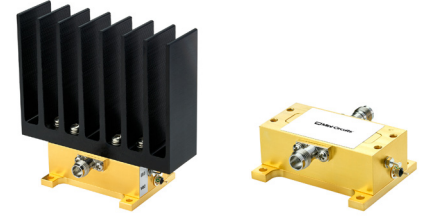

Generic photo used for illustration purposes only

|                   |               |             |
|-------------------|---------------|-------------|
| <b>Model No.</b>  | ZVA-35703+    | ZVA-35703X+ |
| <b>Case Style</b> | VP3085-1      |             |
| <b>Connectors</b> | 1.85mm Female |             |

#### +RoHS Compliant

The +Suffix identifies RoHS Compliance. See our web site for RoHS Compliance methodologies and qualifications

### PRODUCT OVERVIEW

Mini-Circuits' ZVA-35703+ is a coaxial, medium power high frequency wideband amplifier, operating from 35 to 71 GHz. This model operates over a single positive supply range of +10 to +15 V, allowing users to choose their desired operating voltage. Internal DC-DC conversion circuitry maintains constant efficiency over the full input voltage range. The amplifier incorporates several DC-protection features, such as over-voltage, reverse voltage and in-rush current, that protect the amplifier from damage if mishandled during operation. The high frequency operation combined with medium output power makes this amplifier an ideal choice for 5G communications applications..

### KEY FEATURES

| Feature   | Advantages  |
|---|---|
| High Freq amplifier, 35 to 71 GHz                                     | Broadband amplifier focusing on 5G mmWave frequencies up to 71 GHz  |
| Heatsink option   | Model ZVA-35703+ comes with a heatsink, keeping the amplifier cool to the touch during normal operation at room temperature   |
| Excellent gain flatness<br>Low VSWR<br>Medium output power            | The amplifier provides 17.5 dB (typ.) of gain over the entire operating band and has high output power at saturation of 21 dBm (typ.) which makes it a good choice for applications that require a medium or high power amplifier at high frequency |
| Adjustable DC supply voltage  | The device is capable of operating from +10 to +15 V with consistent DC power consumption   |
| DC Protection –<br>Over-voltage<br>Reverse voltage<br>In-rush current | The internal DC circuitry allows the amplifier to be protected from external mishandling that could lead to catastrophic failures in the field  |

REV. OR  
ECO-012191  
ZVA-35703+  
MCL NY  
220317





MEDIUM POWER, WIDEBAND

# High-Frequency Amplifier

## ZVA-35703+ ZVA-35703X+

Mini-Circuits

### ELECTRICAL SPECIFICATIONS AT 25 °C BASEPLATE

| Parameter                                      | Condition (MHz) | ZVA-35703+ <sup>3</sup><br>ZVA-35703X+ <sup>4</sup> |      |                  | Units |
|--|-----------------|---|------|------------------|-------|
|  |                 | Min.  | Typ. | Max.             |       |
| Frequency Range                                |                 | 35000   |      | 71000            | MHz   |
| Gain   | 35000 - 70000   | 15.0  | 17.5 | -                | dB    |
| Output Power at 1dB Compression                | 35000 - 44000   | 17.0  | 19.0 | -                | dBm   |
|  | 44000 - 70000   | 18.0  | 20.0 | -                |       |
| Output Power at Saturation                     | 35000 - 65000   | 20.0  | 21.5 | -                | dBm   |
|  | 65000 - 70000   | 18.5  | 20.5 | -                |       |
| OIP3   | 35000 - 70000   | -   | 28   | -                | dBm   |
| Input VSWR                                     | 35000 - 70000   | -   | 1.5  | 2.0              | :1    |
| Output VSWR <sup>1</sup>                       | 35000 - 70000   | -   | 1.5  | 2.0              | :1    |
| Operating DC Voltage                           |                 | +10   | -    | +15              | V     |
| Device Operating Current at +10 V <sup>2</sup> |                 | -   | 210  | 400 <sup>2</sup> | mA    |

1. Open and short-circuit loads are not recommended at the amplifier output. Ensure proper 50 Ohm load before turning the amplifier "ON".
2. Max. operating current is based on current when amplifier is in saturation.
3. For units with heatsink, limit ambient temperature to 50 °C.
4. For units without heatsink, limit the maximum baseplate temperature to 60 °C.

### MAXIMUM RATINGS<sup>6</sup>

| Parameter                        | Rating   |
|----------------------------------|--|
| Operating temperature            | ZVA-35703+ -40 °C to +50 °C Ambient<br>ZVA-35703X+ -40 °C to + 60 °C Baseplate |
| Storage temperature              | -40 °C to +85 °C   |
| Total Power Dissipation          | 3.6 W  |
| RF Input Power <sup>5</sup> (CW) | +18 dBm  |
| DC Operating Voltage             | +16 V  |

5. Specified under matched load to 50 ohms.
6. Continuous operation is not recommended at these extremes. Permanent damage may occur if any of these limits are exceeded.

### DETERMINING MAXIMUM THERMAL RESISTANCE OF USERS' EXTERNAL HEAT SINK

|  |   |
|--|---|
| $\text{MAXIMUM THERMAL RESISTANCE} = \frac{\text{MAXIMUM OPERATING CASE TEMP} - \text{MAXIMUM USER AMBIENT TEMP}}{\text{POWER DISSIPATION}}$ |   |
| <b>Example:</b>  | MAXIMUM OPERATING CASE TEMP = 50 °C (CHECK MAXIMUM RATINGS TABLE FOR THIS VALUE)<br>MAXIMUM USER AMBIENT TEMP = 30 °C (USER DEFINED)<br>POWER DISSIPATION = 10 WATTS (CHECK MAXIMUM RATINGS TABLE FOR THIS VALUE)<br>THEN MAXIMUM ALLOWABLE THERMAL RESISTANCE = 2 °C/W |







### TYPICAL PERFORMANCE DATA

| Frequency (GHz) | Gain (dB) | Directivity (dB) | VSWR (:1) |      | Pout at 1 dB Compr. (dBm) | Pout at Saturation (dBm) | OIP3 (dBm) |
|-----------------|-----------|------------------|-----------|------|---------------------------|--------------------------|------------|
|                 | 10V       | 10V              | IN        | OUT  | 10V                       | 10V                      | 10V        |
| 35.00           | 17.86     | 36.40            | 1.54      | 1.39 | 19.03                     | 21.05                    | 27.27      |
| 37.00           | 19.10     | 35.20            | 1.37      | 1.35 | 19.25                     | 21.69                    | 27.26      |
| 39.00           | 19.50     | 34.44            | 1.46      | 1.40 | 18.90                     | 21.71                    | 26.75      |
| 41.00           | 18.62     | 33.36            | 1.39      | 1.47 | 18.56                     | 21.44                    | 26.12      |
| 43.00           | 16.91     | 32.96            | 1.52      | 1.46 | 19.43                     | 21.23                    | 26.01      |
| 45.00           | 17.58     | 31.07            | 1.39      | 1.11 | 19.71                     | 21.80                    | 26.30      |
| 47.00           | 17.53     | 32.40            | 1.26      | 1.47 | 19.33                     | 21.72                    | 26.50      |
| 49.00           | 17.58     | 34.71            | 1.31      | 1.14 | 20.08                     | 21.96                    | 26.92      |
| 51.00           | 17.35     | 36.10            | 1.30      | 1.33 | 19.66                     | 21.72                    | 26.86      |
| 53.00           | 17.35     | 36.12            | 1.25      | 1.18 | 20.07                     | 21.94                    | 27.23      |
| 55.00           | 17.26     | 35.54            | 1.27      | 1.15 | 20.27                     | 21.96                    | 27.51      |
| 57.00           | 17.10     | 34.10            | 1.09      | 1.03 | 20.52                     | 22.01                    | 27.96      |
| 59.00           | 17.17     | 35.36            | 1.32      | 1.17 | 20.82                     | 22.07                    | 28.60      |
| 61.00           | 17.39     | 36.20            | 1.41      | 1.14 | 20.90                     | 22.04                    | 29.19      |
| 63.00           | 17.71     | 36.65            | 1.48      | 1.20 | 20.88                     | 21.80                    | 29.59      |
| 65.00           | 17.64     | 39.67            | 1.56      | 1.55 | 20.47                     | 21.23                    | 30.25      |
| 67.00           | 17.89     | 43.96            | 1.12      | 1.36 | 20.10                     | 20.72                    | 31.34      |
| 69.00           | 17.14     | 55.34            | 1.36      | 1.34 | 19.82                     | 20.48                    | 32.45      |
| 71.00           | 16.41     | 52.86            | 1.53      | 1.43 | 19.26                     | 19.85                    | -          |
| 73.00           | 16.07     | 50.07            | 1.41      | 1.11 | 19.01                     | 19.71                    | -          |
| 75.00           | 12.85     | 60.34            | 1.43      | 1.85 | 17.12                     | 18.87                    | -          |

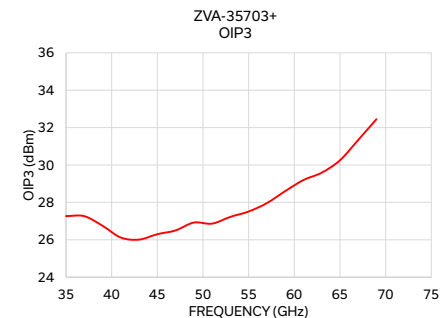
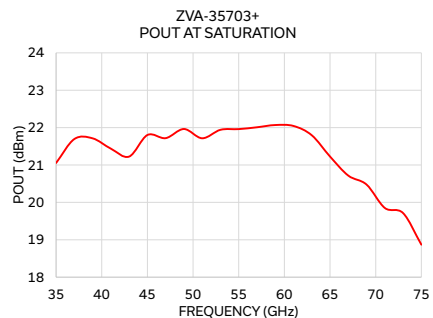
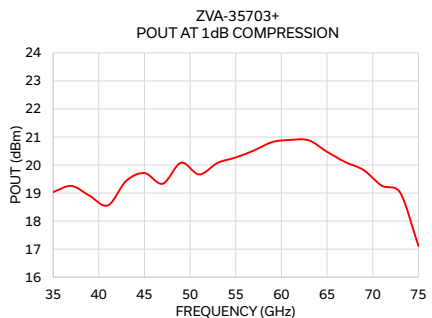
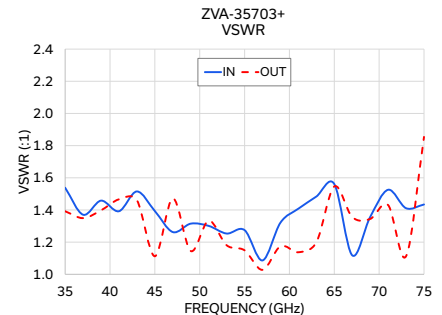
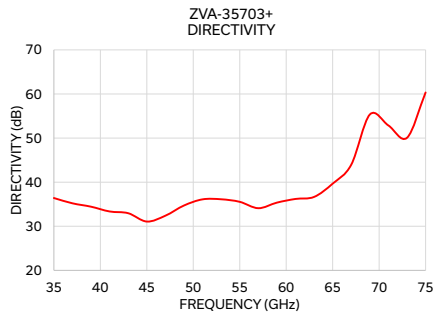
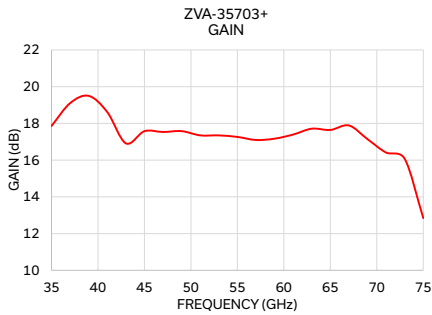

- NOTES**
- A. Performance and quality attributes and conditions not expressly stated in this specification document are intended to be excluded and do not form a part of this specification document.
  - B. Electrical specifications and performance data contained in this specification document are based on Mini-Circuit's applicable established test performance criteria and measurement instructions.
  - C. The parts covered by this specification document are subject to Mini-Circuits standard limited warranty and terms and conditions (collectively, "Standard Terms"); Purchasers of this part are entitled to the rights and benefits contained therein. For a full statement of the standard terms and the exclusive rights and remedies thereunder, please visit Mini-Circuits' website at [www.minicircuits.com/MCLStore/terms.jsp](http://www.minicircuits.com/MCLStore/terms.jsp)

# Coaxial Amplifier

# ZVA-35703+

## Typical Performance Data

| FREQUENCY<br>(GHz) | GAIN<br>(dB)<br>10V | DIRECTIVITY<br>(dB)<br>10V | VSWR (:1) |            | FREQUENCY<br>(GHz) | Pout @ 1 dB<br>COMPRESSION<br>(dBm)<br>10V | Pout at<br>SATURATION<br>(dBm)<br>10V | OIP3<br>(dBm)<br>10V |
|--------------------|---------------------|----------------------------|-----------|------------|--------------------|--|---------------------------------------|----------------------|
|                    |                     |                            | IN<br>10V | OUT<br>10V |                    |  |                                       |                      |
| 35.0               | 17.86               | 36.40                      | 1.54      | 1.39       | 35.0               | 19.0                                       | 21.1                                  | 27.27                |
| 36.0               | 18.48               | 36.21                      | 1.49      | 1.46       | 37.0               | 19.3                                       | 21.7                                  | 27.26                |
| 37.0               | 19.10               | 35.20                      | 1.37      | 1.35       | 39.0               | 18.9                                       | 21.7                                  | 26.75                |
| 38.0               | 19.51               | 34.37                      | 1.36      | 1.27       | 41.0               | 18.6                                       | 21.4                                  | 26.12                |
| 39.0               | 19.50               | 34.44                      | 1.46      | 1.40       | 43.0               | 19.4                                       | 21.2                                  | 26.01                |
| 40.0               | 19.19               | 33.85                      | 1.49      | 1.50       | 45.0               | 19.7                                       | 21.8                                  | 26.30                |
| 41.0               | 18.62               | 33.36                      | 1.39      | 1.47       | 47.0               | 19.3                                       | 21.7                                  | 26.50                |
| 42.0               | 17.60               | 33.23                      | 1.37      | 1.43       | 49.0               | 20.1                                       | 22.0                                  | 26.92                |
| 43.0               | 16.91               | 32.96                      | 1.52      | 1.46       | 51.0               | 19.7                                       | 21.7                                  | 26.86                |
| 44.0               | 17.15               | 31.99                      | 1.53      | 1.29       | 53.0               | 20.1                                       | 21.9                                  | 27.23                |
| 45.0               | 17.58               | 31.07                      | 1.39      | 1.11       | 55.0               | 20.3                                       | 22.0                                  | 27.51                |
| 46.0               | 17.60               | 31.40                      | 1.32      | 1.39       | 57.0               | 20.5                                       | 22.0                                  | 27.96                |
| 47.0               | 17.53               | 32.40                      | 1.26      | 1.47       | 59.0               | 20.8                                       | 22.1                                  | 28.60                |
| 48.0               | 17.53               | 33.37                      | 1.33      | 1.35       | 61.0               | 20.9                                       | 22.0                                  | 29.19                |
| 49.0               | 17.58               | 34.71                      | 1.31      | 1.14       | 63.0               | 20.9                                       | 21.8                                  | 29.59                |
| 50.0               | 17.51               | 35.73                      | 1.26      | 1.20       | 65.0               | 20.5                                       | 21.2                                  | 30.25                |
| 51.0               | 17.35               | 36.10                      | 1.30      | 1.33       | 67.0               | 20.1                                       | 20.7                                  | 31.34                |
| 52.0               | 17.27               | 36.41                      | 1.35      | 1.32       | 69.0               | 19.8                                       | 20.5                                  | 32.45                |
| 53.0               | 17.35               | 36.12                      | 1.25      | 1.18       | 71.0               | 19.3                                       | 19.9                                  | -                    |
| 54.0               | 17.38               | 35.55                      | 1.15      | 1.10       | 73.0               | 19.0                                       | 19.7                                  | -                    |
| 55.0               | 17.26               | 35.54                      | 1.27      | 1.15       | 75.0               | 17.1                                       | 18.9                                  | -                    |
| 56.0               | 17.22               | 35.08                      | 1.25      | 1.10       |                    |  |                                       |                      |
| 57.0               | 17.10               | 34.10                      | 1.09      | 1.03       |                    |  |                                       |                      |
| 58.0               | 17.00               | 34.90                      | 1.24      | 1.14       |                    |  |                                       |                      |
| 59.0               | 17.17               | 35.36                      | 1.32      | 1.17       |                    |  |                                       |                      |
| 60.0               | 17.30               | 35.82                      | 1.34      | 1.14       |                    |  |                                       |                      |
| 61.0               | 17.39               | 36.20                      | 1.41      | 1.14       |                    |  |                                       |                      |
| 62.0               | 17.57               | 35.89                      | 1.46      | 1.16       |                    |  |                                       |                      |
| 63.0               | 17.71               | 36.65                      | 1.48      | 1.20       |                    |  |                                       |                      |
| 64.0               | 17.70               | 38.00                      | 1.53      | 1.32       |                    |  |                                       |                      |
| 65.0               | 17.64               | 39.67                      | 1.56      | 1.55       |                    |  |                                       |                      |
| 66.0               | 17.76               | 41.01                      | 1.39      | 1.61       |                    |  |                                       |                      |
| 67.0               | 17.89               | 43.96                      | 1.12      | 1.36       |                    |  |                                       |                      |
| 68.0               | 17.63               | 48.82                      | 1.11      | 1.09       |                    |  |                                       |                      |
| 69.0               | 17.14               | 55.34                      | 1.36      | 1.34       |                    |  |                                       |                      |
| 70.0               | 16.55               | 53.51                      | 1.66      | 1.50       |                    |  |                                       |                      |
| 71.0               | 16.41               | 52.86                      | 1.53      | 1.43       |                    |  |                                       |                      |
| 72.0               | 16.58               | 50.19                      | 1.11      | 1.22       |                    |  |                                       |                      |
| 73.0               | 16.07               | 50.07                      | 1.41      | 1.11       |                    |  |                                       |                      |
| 74.0               | 14.49               | 56.31                      | 1.63      | 1.61       |                    |  |                                       |                      |
| 75.0               | 12.85               | 60.34                      | 1.43      | 1.85       |                    |  |                                       |                      |

## Typical Performance Curves

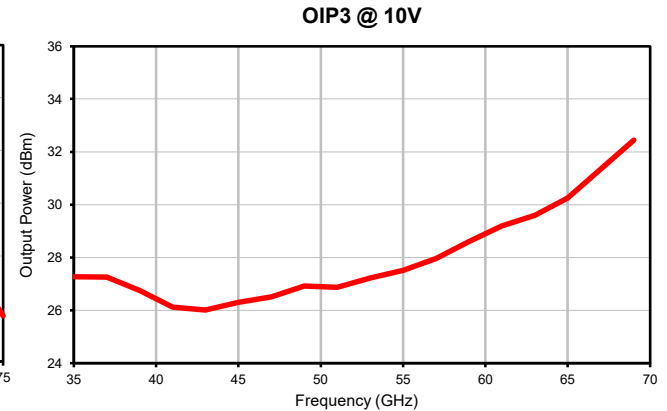
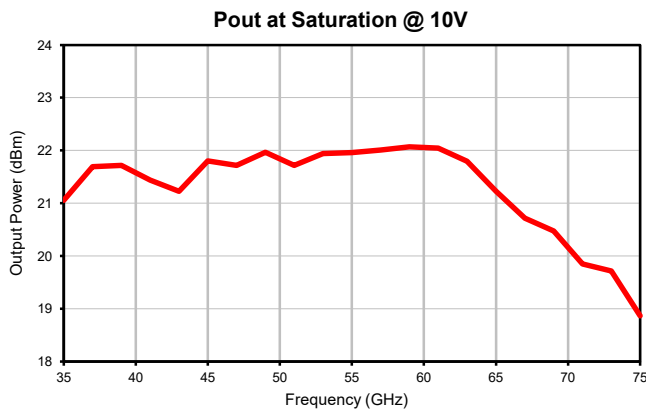
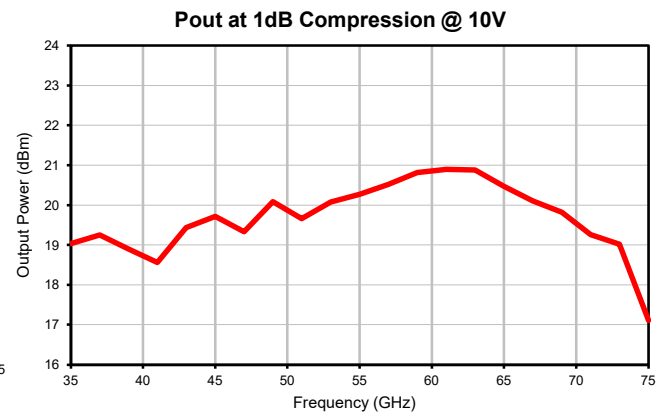
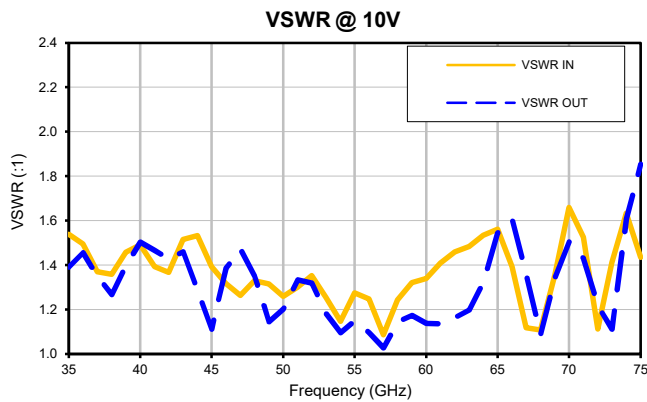
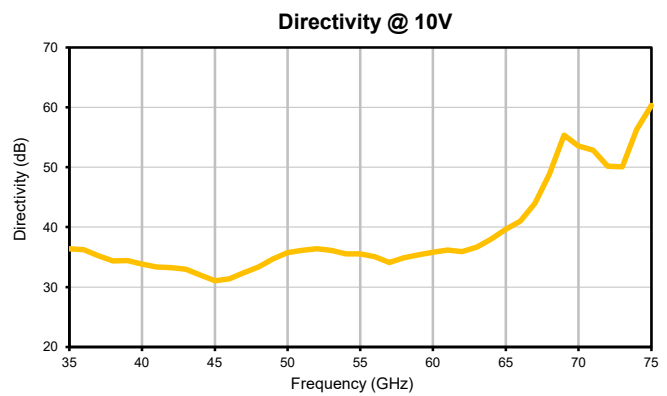
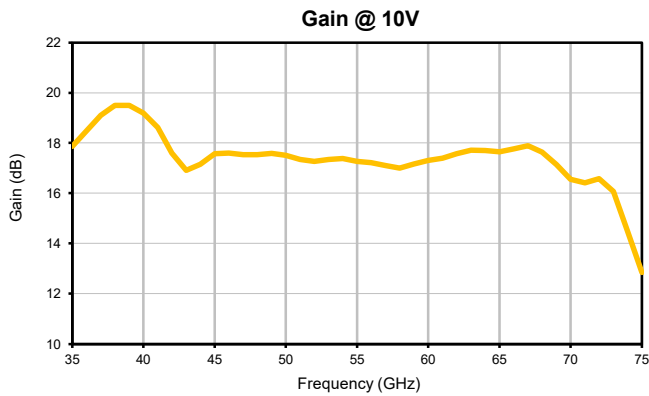

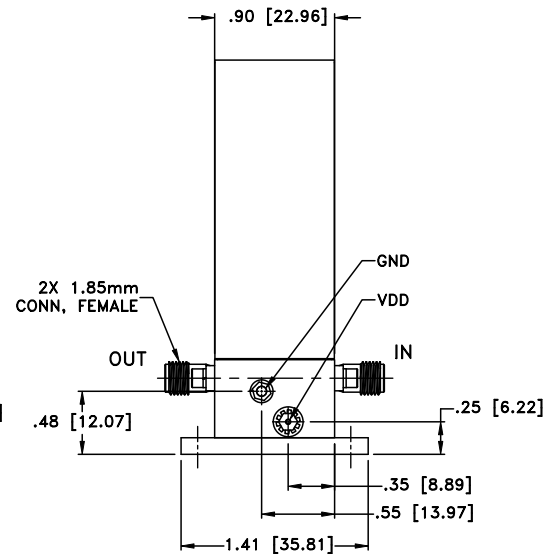
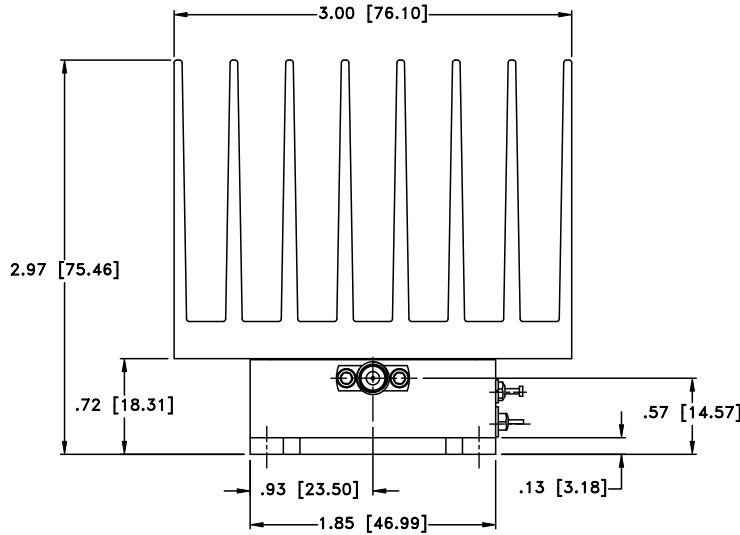
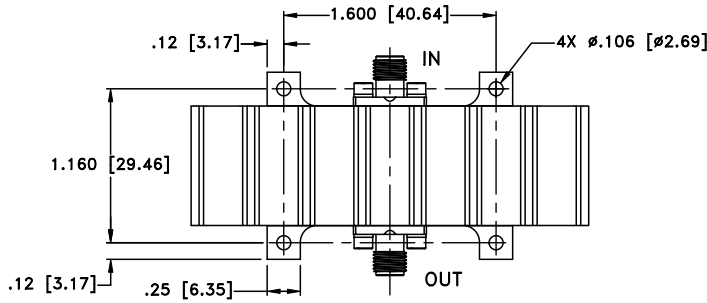

OQWPVKP I KPHQTOCVKQP'QH"OQFGN" YKIVJQWV"JGCVUKPM

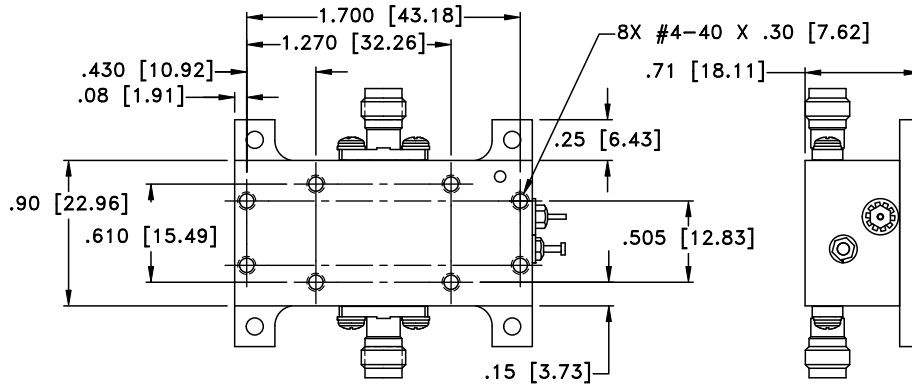

Y gki j v< 3570'i tco u="Y kj qw'j gcukpm'690'i tco u

F ko gpukqpu'ctg'lp'kpej gu"\*o o +0Vqngtcpegu<4"Rr0025=5"Rr00237

Pqvgu<

30 Ecug"o cvgtkn<Cnwo kpwo

40 Ecug'hpkuj <I qrf 'r rvpki

50 J gcv'ukpm'hpkuj <Drcem'cpqf k g

60 Tghgt "v'j g'lpf kxk wcn'o qf gnlf cxe'uj gg'v'ht "j g'v'f r g'qh'eappgevtu'cxckcdng

70 Uj cr g'qh'eappgevt'hcpi g'o c { "xct {



P.O. Box 350166, Brooklyn, New York 11235-0003 (718) 934-4500 Fax (718) 332-4661 For detailed performance specs & shopping online see Mini-Circuits web site

The Design Engineers Search Engine Provides ACTUAL Data Instantly From MINI-CIRCUITS At: www.minicircuits.com



RF/IF MICROWAVE COMPONENTS

All Mini-Circuits products are manufactured under exacting quality assurance and control standards, and are capable of meeting published specifications after being subjected to any or all of the following physical and environmental test.

| <b>Specification</b>  | <b>Test/Inspection Condition</b>      | <b>Reference/Spec</b>                          |
|-----------------------|---------------------------------------|--|
| Operating Temperature | -40° to +60° C<br>Baseplate Temp      | Individual Model Data Sheet                    |
| Storage Temperature   | -40° to +85° C<br>Ambient Environment | Individual Model Data Sheet                    |
| Burn-in               | (DC on)<br>72 hours at 25°C           | ----   |
| Thermal Shock         | -40° C to +85°C, 100 cycles           | Transition time = 5 mins, Dwell time = 30 mins |
| Vibration             | Random Vibration<br>(non-operating)   | MIL-STD-883K, Method 2025, Cond. 1A            |