



COAXIAL WIDEBAND

Medium Power Amplifier

ZVA-213A-S+ ZVA-213AX-S+

50Ω 800 MHz to 21 GHz

THE BIG DEAL

- Wideband 800 MHz to 21 GHz
- Output Power 0.5 watt, at Saturation
- Excellent Gain Flatness, ± 1.5 dB typ. from 800 MHz to 21 GHz
- Over-Voltage & Reverse Voltage Protection
- Single Supply Voltage of +12 VDC

APPLICATIONS

- Lab use
- Wideband Test and Measurement
- 5G
- Driver Amplifier
- Aerospace and Defense
- Radios, Radars and Satellite Systems
- Industrial, Scientific and Medical



Generic photo used for illustration purposes only

Model No.	ZVA-213A-S+	ZVA-213AX-S+
Case Style	AV2554-3	
Connectors	SMA female	

+RoHS Compliant

The +Suffix identifies RoHS Compliance. See our web site for RoHS Compliance methodologies and qualifications

PRODUCT OVERVIEW

Mini-Circuits' ZVA-213A-S+ is a coaxial, wideband RF amplifier capable of operating from 800 MHz to 21 GHz. The design can deliver output power of +27 dBm at saturation and +24 dBm typ. at 1dB compression, making it an ideal choice for applications requiring a wideband driver amplifier. With a low noise figure of 4 dB typ. across majority of the band, it can be used in test setups that require higher dynamic range. Complementary safety features such as protection against DC transients, over-voltage and reverse voltage conditions ensure that the amplifier stays protected against mishandling.

KEY FEATURES

Feature	Advantages
Ultra-wideband, 800 MHz to 21 GHz	Enables a single amplifier to be used in a wide range of applications.
Excellent gain flatness, ± 1.5 dB across full frequency range	Provides consistent performance across its operating frequency, minimizing the need for external equalizing networks in wideband applications.
Low noise and high IP3: <ul style="list-style-type: none"> • NF, 4 dB typ. • IP3, +34 dBm typ 	The combination of low noise and high IP3 makes the ZVA-213A-S+ ideal for use in receiver front ends (RFE) as it gives the user the advantages of sensitivity and two-tone IM performance at both ends of the dynamic range.
Rugged design	Built-in protection against DC transients, reverse voltage and over-voltage provides added reliability for demanding operating conditions.

REV. A
ECO-011505
ZVA-213A-S+
AD/CP/PS
220211



ELECTRICAL SPECIFICATION AT 25 °C (AMBIENT), $V_{DD} = 12V$ TYP.

Parameter	Condition (GHz)	ZVA-213A-S+ ZVA-213AX-S+			Units
		Min.	Typ.	Max.	
Frequency Range		0.8		21	GHz
Gain	0.8 – 21	21	24		dB
Gain Flatness	0.8 – 21		± 1.5		dB
Output Power at 1dB compression	0.8 – 21	20	24		dBm
Saturated Output Power	0.8 – 21		27		
Noise Figure	0.8 – 21		4		dB
Output IP3 (output power = 10 dBm/tone)	0.8 – 21		34		dBm
Input VSWR	0.8 – 21		1.35		:1
Output VSWR ¹	0.8 – 21		1.35		:1
DC Supply Voltage		11	12	13	V
Supply Current ²			400	550	mA

1. Open and short-circuit loads are not recommended at the amplifier output. Ensure proper 50 ohm load before turning the amplifier "ON".

2. Maximum Supply Current is specified at Saturated Output Power.

MAXIMUM RATINGS⁵

Parameter	Ratings
Operating Temperature (Ambient)	-40° C to +50° C
Operating Temperature (Baseplate)	-40° C to +75° C
Storage Temperature	-55° C to +125° C
Total Power Dissipation ³	6.5 watts
RF Input Power ⁴ (CW), VDD=12V	+15 dBm
DC Voltage	+14V

3. Total Power Dissipation is specified at Saturated Output Power.

4. Specified under matched load to 50 ohms.

5. Continuous operation is not recommended at these extremes.
Permanent damage may occur if any of these limits are exceeded.

DETERMINING MAXIMUM THERMAL RESISTANCE OF USERS' EXTERNAL HEAT SINK

$\text{MAXIMUM THERMAL RESISTANCE} = \frac{\text{MAXIMUM OPERATING CASE TEMP} - \text{MAXIMUM USER AMBIENT TEMP}}{\text{POWER DISSIPATION}}$	
Example:	MAXIMUM OPERATING CASE TEMP = 50 °C (CHECK MAXIMUM RATINGS TABLE FOR THIS VALUE) MAXIMUM USER AMBIENT TEMP = 30 °C (USER DEFINED) POWER DISSIPATION = 10 WATTS (CHECK MAXIMUM RATINGS TABLE FOR THIS VALUE) THEN MAXIMUM ALLOWABLE THERMAL RESISTANCE = 2 °C/W



OUTLINE DRAWING

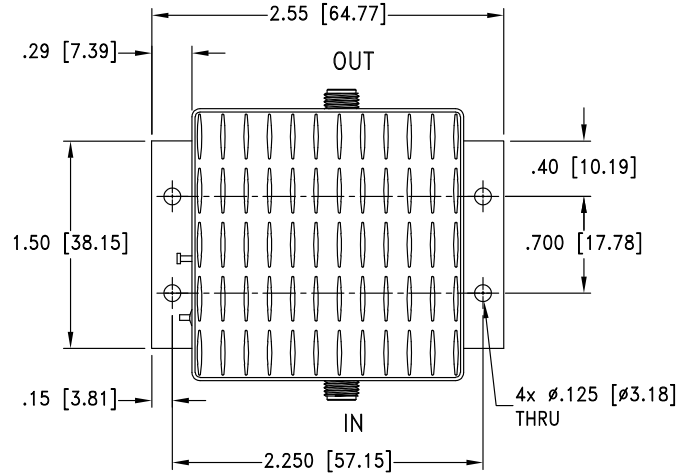
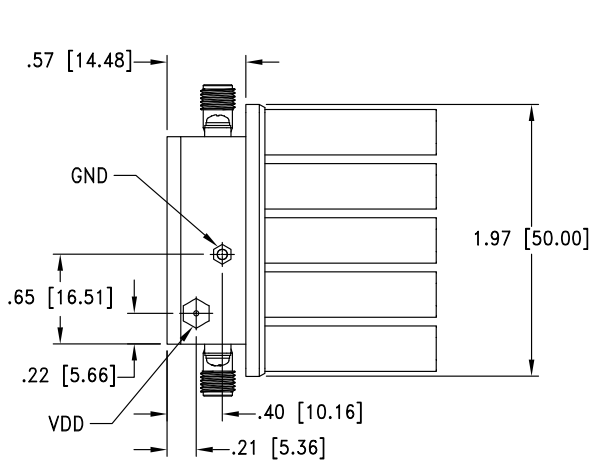

MOUNTING INFORMATION OF MODEL WITHOUT HEATSINK

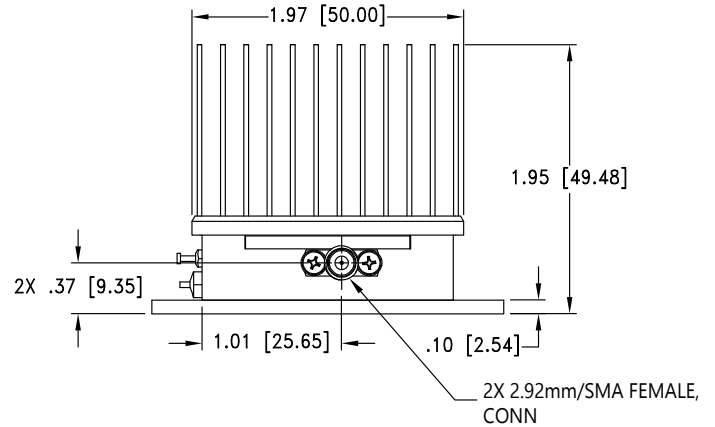
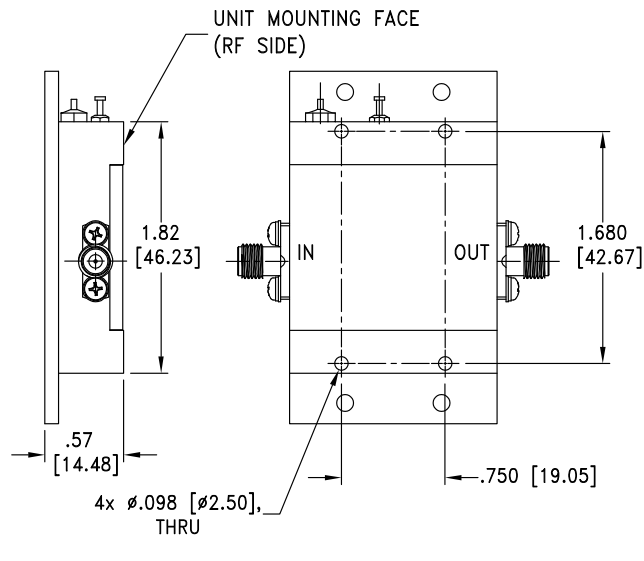

Weight without heatsink: 345 grams; Weight: 455 grams;

Dimensions are in inches [mm]. Tolerances: 2 Pl.±.03; 3 Pl. ±.015



TYPICAL PERFORMANCE DATA/CURVES

Frequency (GHz)	Gain (dB)	Directivity (dB)	VSWR (:1)		Noise Figure (dB)	Pout at 1 dB Compr. (dBm)	Pout at Saturation (dBm)	OIP3 (dBm)
	12V	12V	IN	OUT	12V	12V	12V	12V
0.80	25.28	73.84	1.21	1.14	5.90	27.03	29.37	39.70
1.00	25.51	62.87	1.21	1.13	5.48	27.33	29.54	38.86
2.00	24.94	77.98	1.21	1.31	5.15	27.59	29.27	35.76
3.00	25.02	69.90	1.16	1.21	4.81	28.04	29.18	34.86
4.00	24.80	69.94	1.08	1.14	4.11	28.32	29.32	35.70
5.00	24.49	60.72	1.19	1.05	3.37	28.51	29.52	35.55
6.00	24.36	58.65	1.24	1.02	2.97	28.23	29.53	34.76
8.00	24.14	56.35	1.51	1.21	2.86	26.90	28.40	34.08
10.00	23.46	61.15	1.31	1.22	2.93	25.91	27.21	32.98
12.00	23.41	56.20	1.22	1.33	2.96	24.83	26.75	32.39
14.00	23.68	51.16	1.50	1.28	3.44	25.33	27.62	32.83
16.00	24.24	44.47	1.29	1.12	3.72	25.04	28.22	32.25
18.00	23.54	40.88	1.12	1.56	4.16	25.47	27.57	31.84
20.00	23.66	41.15	1.32	1.26	4.51	24.71	27.15	32.80
21.00	23.94	39.26	1.27	1.15	4.82	24.40	27.04	31.97

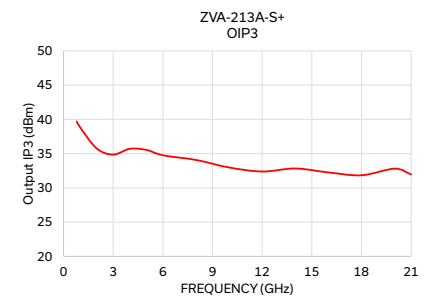
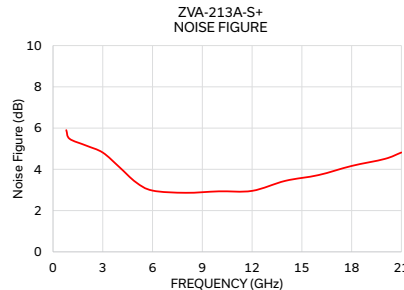
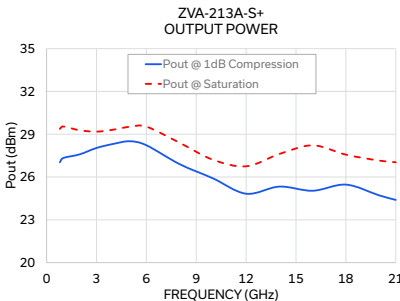
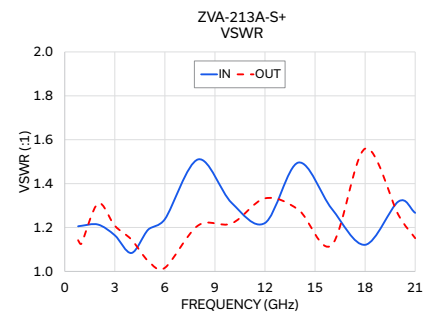
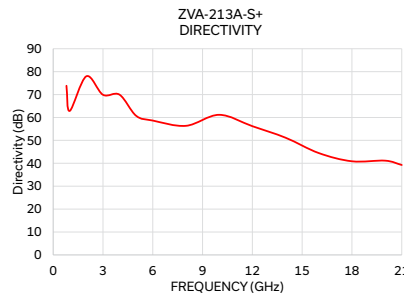
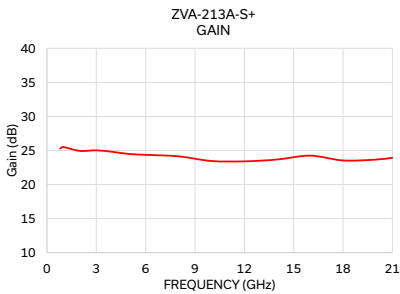

NOTES

- A. Performance and quality attributes and conditions not expressly stated in this specification document are intended to be excluded and do not form a part of this specification document.
- B. Electrical specifications and performance data contained in this specification document are based on Mini-Circuit's applicable established test performance criteria and measurement instructions.
- C. The parts covered by this specification document are subject to Mini-Circuits standard limited warranty and terms and conditions (collectively, "Standard Terms"); Purchasers of this part are entitled to the rights and benefits contained therein. For a full statement of the standard. Terms and the exclusive rights and remedies thereunder, please visit Mini-Circuits' website at www.minicircuits.com/MCLStore/terms.jsp

Typical Performance Data

FREQUENCY (GHz)	GAIN (dB) 12V	DIRECTIVITY (dB) 12V	VSWR (:1)		NOISE FIGURE (dB) 12V	Pout @ 1 dB COMPRESSION (dBm) 12V	OUTPUT IP3 (dBm) 12V
			IN 12V	OUT 12V			
0.8	25.28	73.84	1.21	1.14	5.90	29.37	39.70
0.9	25.41	69.69	1.21	1.12	5.67	29.22	39.43
1.0	25.51	62.87	1.21	1.13	5.48	28.87	38.86
1.2	25.83	74.46	1.21	1.12	5.31	27.97	37.46
1.4	25.61	67.07	1.20	1.21	5.19	27.17	38.91
1.6	25.32	66.21	1.19	1.27	5.12	26.36	36.98
1.8	25.08	66.45	1.20	1.30	4.99	25.62	35.98
2.0	24.94	77.98	1.21	1.31	5.15	25.34	35.76
2.2	24.84	63.78	1.23	1.29	5.14	25.00	34.96
2.4	24.86	65.92	1.23	1.27	5.15	24.87	35.34
2.6	24.90	67.50	1.22	1.25	4.85	24.68	34.86
2.8	24.99	74.51	1.19	1.23	5.00	24.66	35.17
3.0	25.02	69.90	1.16	1.21	4.81	24.62	34.86
3.2	25.04	70.36	1.13	1.18	4.68	24.63	36.42
3.4	25.03	86.10	1.10	1.19	4.41	24.48	35.67
3.6	25.00	67.95	1.08	1.18	4.36	24.42	34.78
3.8	24.88	65.62	1.07	1.17	4.17	24.52	35.78
4.0	24.80	69.94	1.08	1.14	4.11	24.12	35.70
4.2	24.72	67.13	1.11	1.12	4.01	23.89	35.92
4.4	24.63	62.84	1.14	1.10	3.74	23.99	35.40
4.6	24.54	76.31	1.15	1.08	3.65	23.89	35.32
4.8	24.50	69.18	1.17	1.06	3.47	23.72	34.91
5.0	24.49	60.72	1.19	1.05	3.37	23.60	35.55
5.5	24.41	59.78	1.22	1.01	3.13	23.45	35.19
6.0	24.36	58.65	1.24	1.02	2.97	23.38	34.76
6.5	24.30	61.61	1.30	1.03	2.72	23.14	34.44
7.0	24.31	54.19	1.38	1.11	2.68	23.17	34.19
7.5	24.32	54.40	1.47	1.13	2.63	23.18	34.09
8.0	24.14	56.35	1.51	1.21	2.86	23.00	34.08
8.5	24.16	62.49	1.48	1.26	2.71	22.97	34.20
9.0	23.52	55.39	1.49	1.25	2.59	22.33	34.10
9.5	23.58	52.31	1.40	1.23	3.20	22.50	33.61
10.0	23.46	61.15	1.31	1.22	2.93	22.17	32.98
10.5	23.48	56.52	1.23	1.24	2.88	22.18	32.96
11.0	23.47	55.89	1.17	1.24	2.79	22.06	32.77
11.5	23.43	54.43	1.18	1.28	3.00	21.93	32.33
12.0	23.41	56.20	1.22	1.33	2.96	22.02	32.39
12.5	23.42	52.42	1.29	1.47	3.29	22.04	32.39
13.0	23.45	51.54	1.39	1.44	3.35	21.98	32.23
13.5	23.55	52.21	1.47	1.43	3.46	22.29	32.46
14.0	23.68	51.16	1.50	1.28	3.44	22.49	32.83
14.5	23.84	45.68	1.45	1.19	3.46	22.55	32.87
15.0	24.00	44.92	1.34	1.07	3.38	22.64	32.38
15.5	24.16	42.34	1.27	1.09	3.61	22.88	32.28
16.0	24.24	44.47	1.29	1.12	3.72	22.83	32.25
16.5	24.17	46.28	1.34	1.20	3.85	22.87	33.27
17.0	24.00	43.45	1.33	1.31	3.98	22.90	33.26
17.5	23.78	42.51	1.22	1.44	4.11	22.52	32.63
18.0	23.54	40.88	1.12	1.56	4.16	22.09	31.84
18.5	23.44	39.78	1.10	1.62	4.29	22.08	31.67
19.0	23.50	40.43	1.16	1.50	4.46	22.14	32.16
19.5	23.59	43.13	1.28	1.45	4.52	22.30	32.03
20.0	23.66	41.15	1.32	1.26	4.51	22.37	32.80
20.5	23.79	39.44	1.32	1.15	4.68	22.43	32.14
21.0	23.94	39.26	1.27	1.15	4.82	22.68	31.97

Coaxial Amplifier

ZVA-213A-S+

Typical Performance Curves

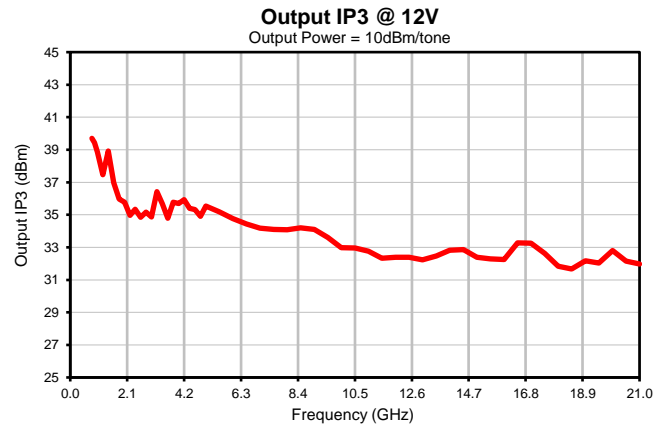
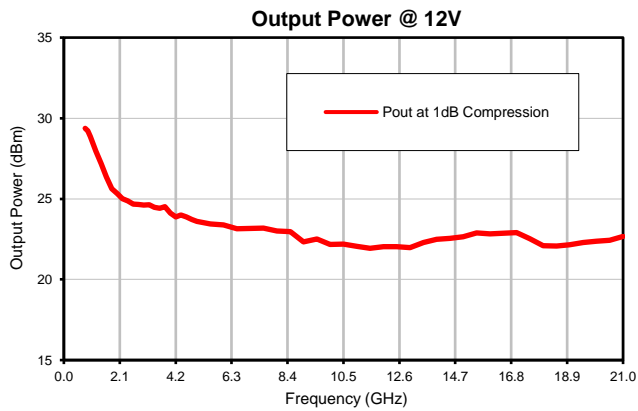
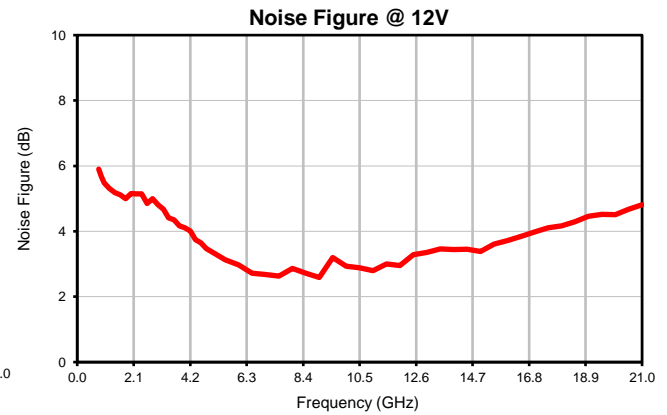
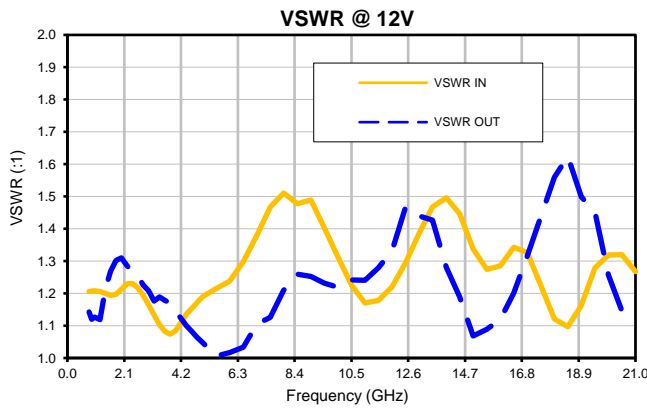
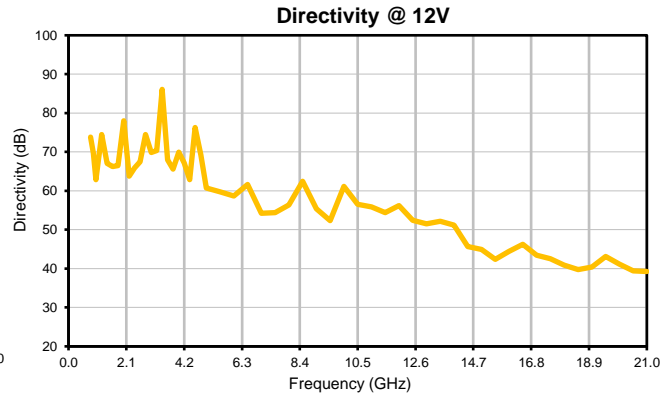
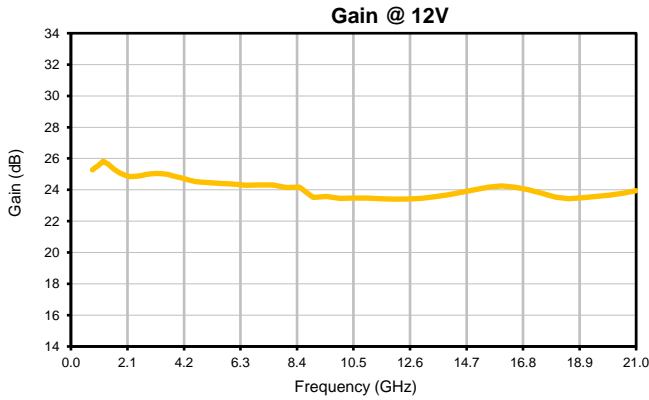

Outline Dimensions

AV2554-3

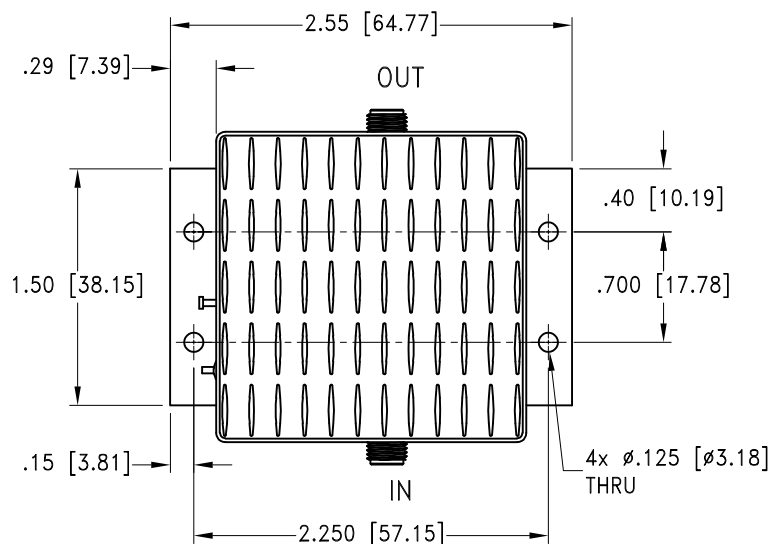
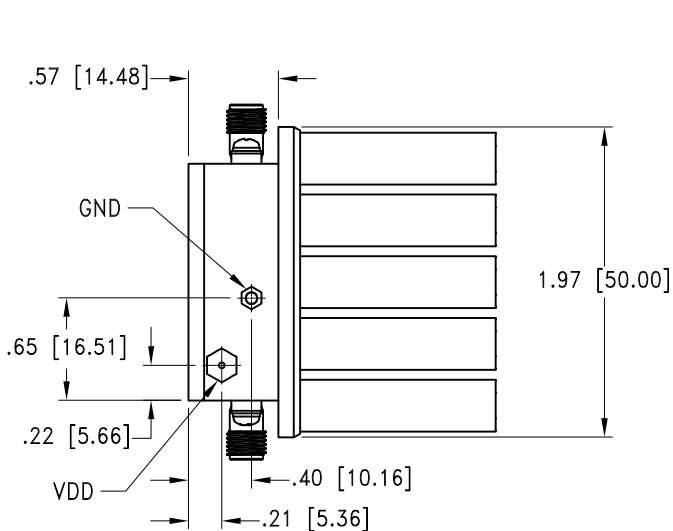

MOUNTING INFORMATION OF MODEL WITHOUT HEATSINK

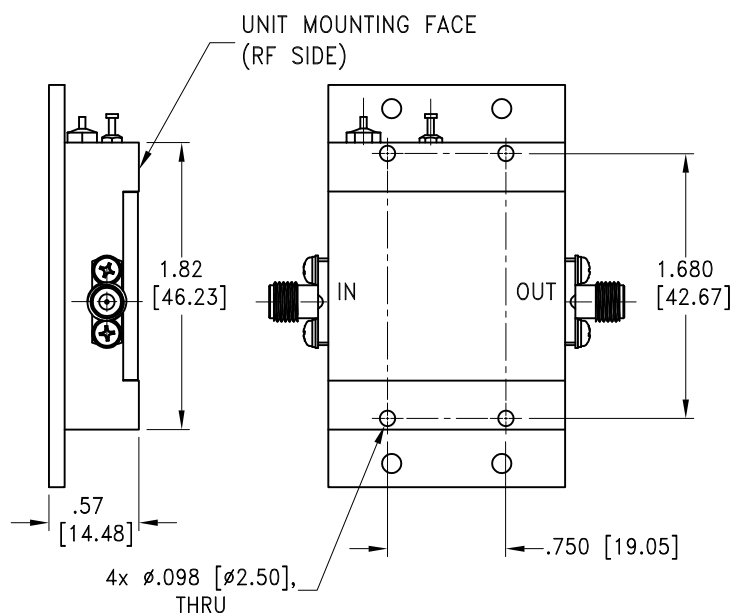

Weight without heatsink: 345 grams;

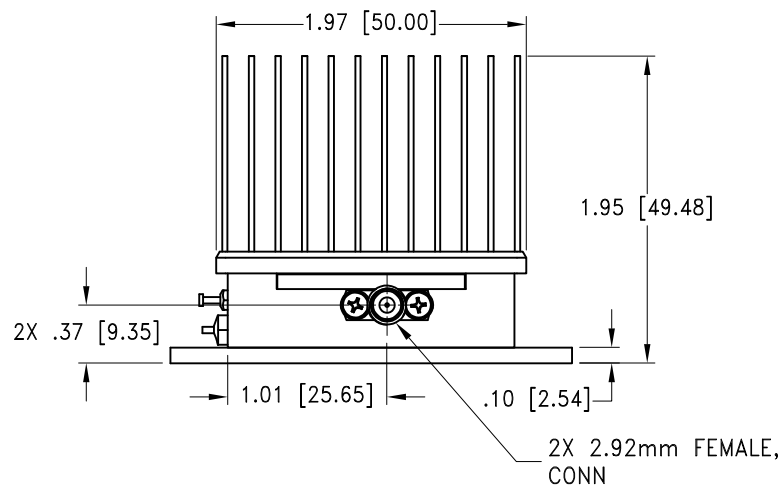

Weight: 455 grams;

Dimensions are in inches (mm). Tolerances: 2 Pl. \pm .03; 3 Pl. \pm .015

Notes:

1. Case material: Brass
2. Case finish: Gold plate.
3. Heat sink finish: Black anodize.

Mini-Circuits
ISO 9001 ISO 14001 CERTIFIED

ALL NEW
minicircuits.com

P.O. Box 350166, Brooklyn, New York 11235-0003 (718) 934-4500 Fax (718) 332-4661 For detailed performance specs & shopping online see Mini-Circuits web site



The Design Engineers Search Engine Provides ACTUAL Data Instantly From MINI-CIRCUITS At: www.minicircuits.com

RF/IF MICROWAVE COMPONENTS

All Mini-Circuits products are manufactured under exacting quality assurance and control standards, and are capable of meeting published specifications after being subjected to any or all of the following physical and environmental test.

Specification	Test/Inspection Condition	Reference/Spec
Operating Temperature	-55° to 85°C base plate temp	Individual Model Data Sheet
Storage Temperature	-65° to 150°C	Individual Model Data Sheet
Thermal Shock	-55° to 100°C, 100 cycles	MIL-STD-202, Method 107
Vibration (High Frequency)	Category 24, Exposure level figures 514C-17 General use, random, 20-2000Hz, 1 hr per axis	MIL-STD-810, Method 514.5
Mechanical Shock	40Gs, 11ms, 18 shocks: 3 each direction), each axis	MIL-STD-810, Method 516.5-II