

Coaxial

Power Detector

ZV47-K44RMS+

50Ω, -35dBm to 0dBm, 100 to 40000 MHz

The Big Deal

- Ultra-wideband, 100 MHz to 40 GHz
- Wide dynamic range of input power, -35 to 0 dBm
- High accuracy, ±0.5 dB typ. linearity error
- Single positive supply voltage, +3.3V



CASE STYLE: AV2578-4

Product Overview

Mini-Circuits' ZV47-K44RMS+ is a high-accuracy RMS power detector that covers a wide RF input bandwidth from 100 MHz to 40 GHz. The DC output voltage of the detector provides an accurate representation of the average signal power applied to the RF input. This device provides a linear-in-dB response with 29mV/dB logarithmic slope over its 35 dB dynamic range with typically better than ±1 dB accuracy. It comes in a compact, gold over nickel plated brass alloy case (0.84 x 0.96 x 0.37") with 2.92mm RF connectors.

Key Features

Feature	Advantages
Ultra-wideband, 100 to 40000 MHz	Covers a wide range of applications including test and measurement, point-to-point microwave links and power control applications
Wide dynamic range of input power, -35 to 0 dBm	Suited for RMS measurement of wave forms with crest factor up to 12 dB as well as wave forms with variable crest factor with typically better than ±1 dB accuracy.
High accuracy, ±0.5 dB typ. linearity error	Customers can use this product in applications that require high-accuracy measurement.
Single supply voltage, +3.3V	Simplifies setup of power supply. Low power consumption with 30mA typical supply current draw.

Notes

- A. Performance and quality attributes and conditions not expressly stated in this specification document are intended to be excluded and do not form a part of this specification document.
B. Electrical specifications and performance data contained in this specification document are based on Mini-Circuit's applicable established test performance criteria and measurement instructions.
C. The parts covered by this specification document are subject to Mini-Circuits standard limited warranty and terms and conditions (collectively, "Standard Terms"); Purchasers of this part are entitled to the rights and benefits contained therein. For a full statement of the Standard Terms and the exclusive rights and remedies thereunder, please visit Mini-Circuits' website at www.minicircuits.com/MCLStore/terms.jsp



Coaxial Power Detector

ZV47-K44RMS+

50Ω, -35dBm to 0dBm, 100 to 40000 MHz

Maximum Ratings

Operating Temperature	-40°C to 85°C
Storage Temperature	-55°C to 100°C
DC Power:	
Max. voltage	3.8V
Max. current	35mA
Input Power	+15dBm

Permanent damage may occur if any of these limits are exceeded.

Coaxial Connections

RF IN	1
DC OUT	4
Vcc (+3.3V)	2
GROUND	3

Outline Drawing

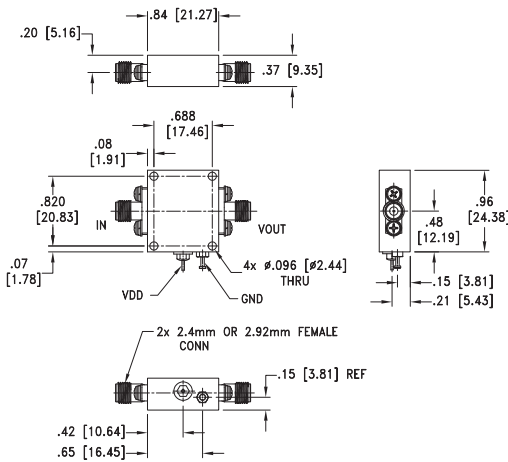

NOTE: When soldering the DC connections, caution must be used to avoid overheating the DC terminals. See Application Note [AN-40-10](#).

Simplified Functional Diagram

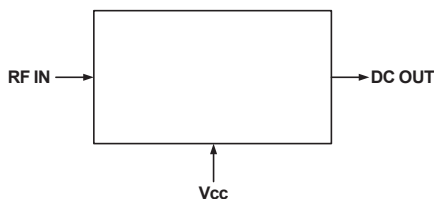

Features

- Ultra wide matched input freq. range: 100 MHz to 40GHz
- 35dB Linear Dynamic Range (< ±1 Error)
- ±1dB Flat Response from 200MHz to 30GHz
- Accurate RMS Power Measurement of High Crest Factors (Up to 12dB) Modulated Waveforms
- Low supply current: 30mA at 3.3V typical.

Applications

- Point-to-Point Microwave Links
- Instrumentation and Measurement Equipment
- Military Radios
- LTE, WiFi, WiMAX Wireless Networks
- RMS Power Measurement
- Receive and Transmit Gain Control
- RF PA Transmit Power Control



Generic photo used for illustration purposes only

CASE STYLE: AV2578-4

Connectors	Model
2.92mm Fem	ZV47-K44RMS+

+RoHS Compliant

The +Suffix identifies RoHS Compliance. See our web site for RoHS Compliance methodologies and qualifications

Electrical Specifications at 25°C

Parameter	Frequency (MHz)	Min.	Typ.	Max.	Units
Frequency Range		100		40000	MHz
Dynamic Range at ±1dB Error	100 - 40000		-35 to 0		dBm
Output Voltage Range	100 - 40000		0 - 1.2		V
Slope	100 - 40000		+29		mV/dB
VSWR	100 - 40000		1.6		(:1)
Pulse Responsive Time	Rise	100 - 40000		2.9	µsec
	Fall	100 - 40000		8.1	
DC Operating Power	Vcc	100 - 40000	2.7	3.3	V
	Current	100 - 40000		30	mA

OUTPUT VOLTAGE vs. INPUT POWER @ +25C

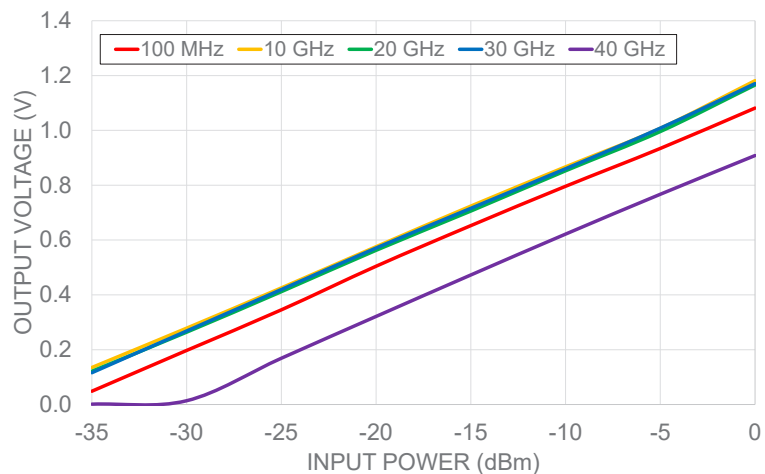

Notes

- Performance and quality attributes and conditions not expressly stated in this specification document are intended to be excluded and do not form a part of this specification document.
- Electrical specifications and performance data contained in this specification document are based on Mini-Circuit's applicable established test performance criteria and measurement instructions.
- The parts covered by this specification document are subject to Mini-Circuits standard limited warranty and terms and conditions (collectively, "Standard Terms"); Purchasers of this part are entitled to the rights and benefits contained therein. For a full statement of the Standard Terms and the exclusive rights and remedies thereunder, please visit Mini-Circuits' website at www.minicircuits.com/MCLStore/terms.jsp



VSWR vs. FREQUENCY OVER TEMPERATURE RANGE

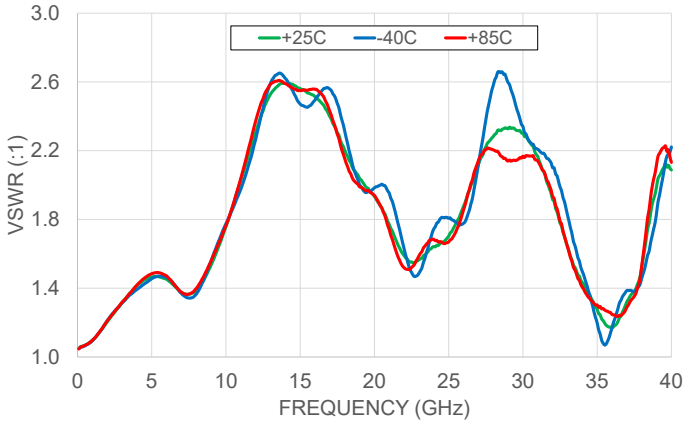

INPUT POWER DEVIATION FROM IDEAL vs. INPUT POWER @ FREQUENCY 100 MHz

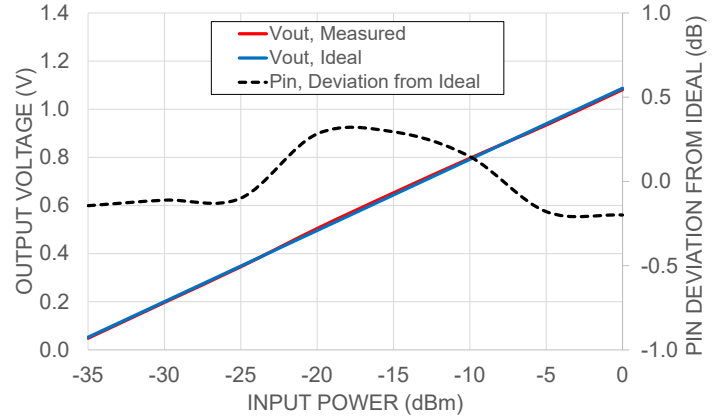

INPUT POWER DEVIATION FROM IDEAL vs INPUT POWER @ FREQUENCY 10 GHz

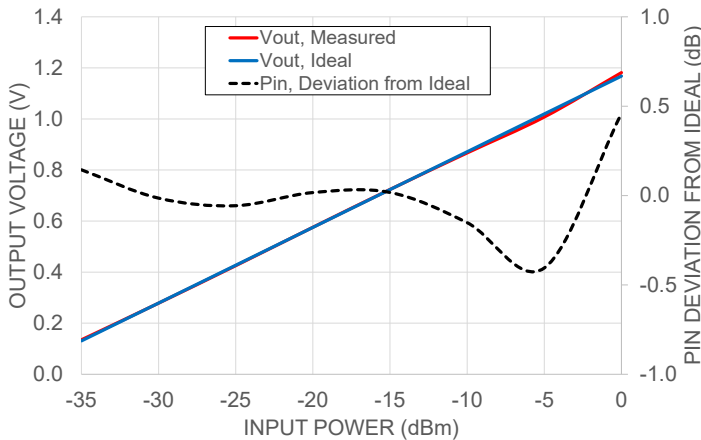

INPUT POWER DEVIATION FROM IDEAL vs INPUT POWER @ FREQUENCY 20 GHz

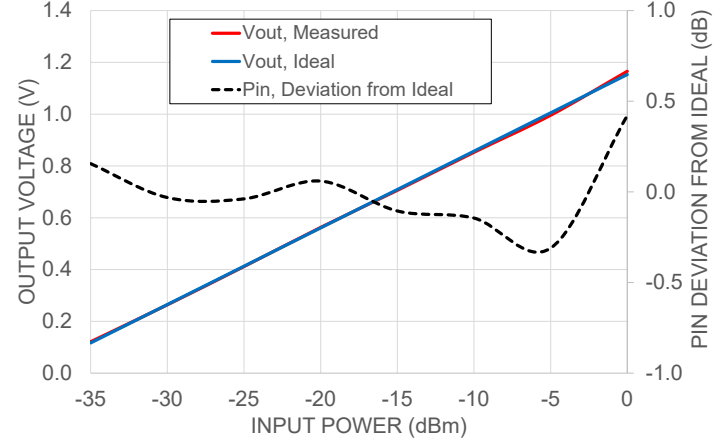

INPUT POWER DEVIATION FROM IDEAL vs INPUT POWER @ FREQUENCY 30 GHz

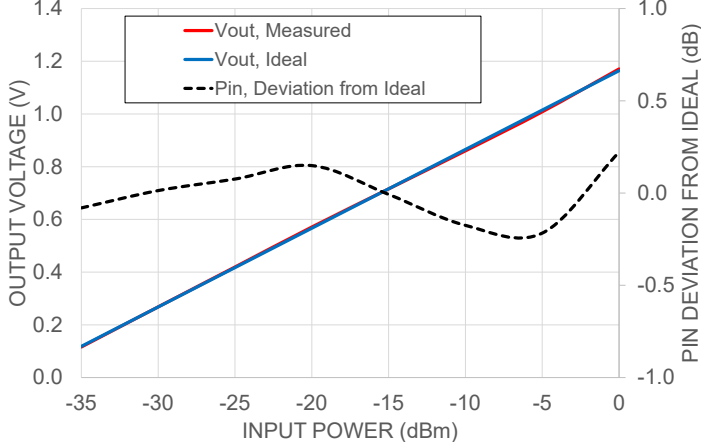

INPUT POWER DEVIATION FROM IDEAL vs INPUT POWER @ FREQUENCY 40 GHz

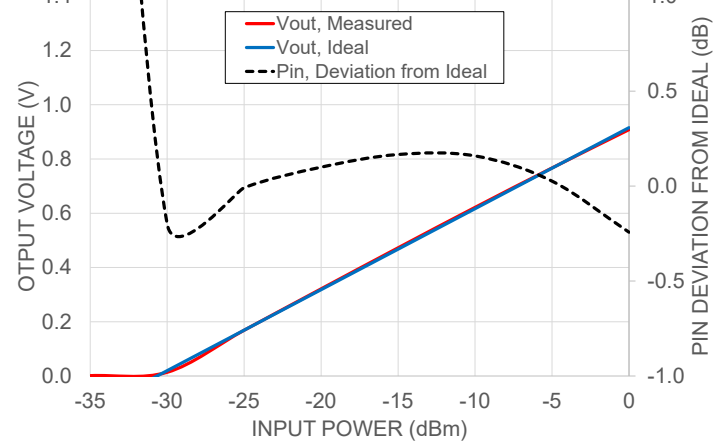

Notes

- A. Performance and quality attributes and conditions not expressly stated in this specification document are intended to be excluded and do not form a part of this specification document.
- B. Electrical specifications and performance data contained in this specification document are based on Mini-Circuit's applicable established test performance criteria and measurement instructions.
- C. The parts covered by this specification document are subject to Mini-Circuits standard limited warranty and terms and conditions (collectively, "Standard Terms"); Purchasers of this part are entitled to the rights and benefits contained therein. For a full statement of the Standard Terms and the exclusive rights and remedies thereunder, please visit Mini-Circuits' website at www.minicircuits.com/MCLStore/terms.jsp



OUTPUT VOLTAGE vs. FREQUENCY OVER TEMPERATURE RANGE @ INPUT POWER -35dBm

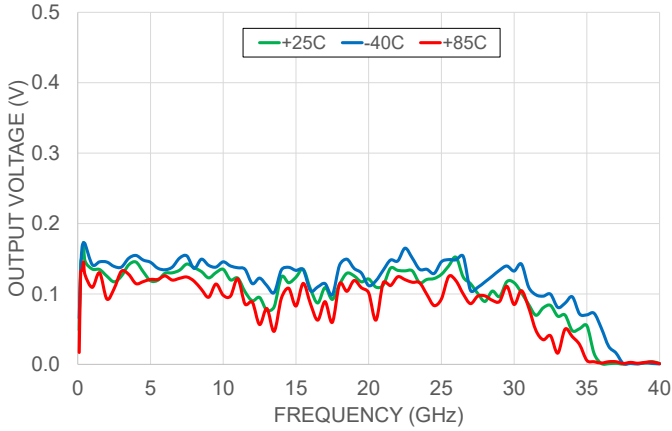

OUTPUT VOLTAGE vs. FREQUENCY OVER TEMPERATURE RANGE @ INPUT POWER -20dBm

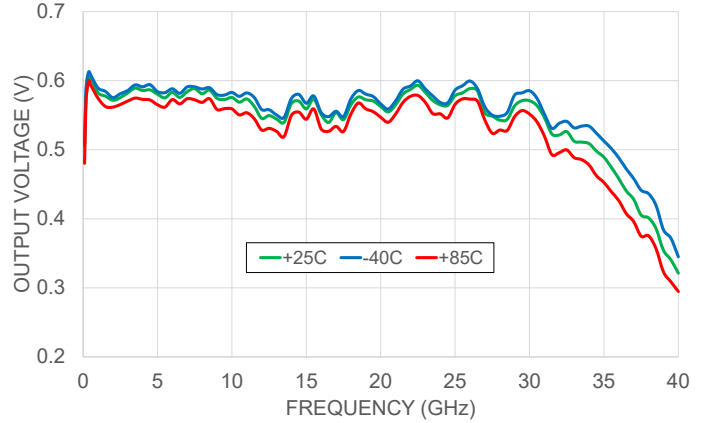

OUTPUT VOLTAGE vs. FREQUENCY OVER TEMPERATURE RANGE @ INPUT POWER 0dBm

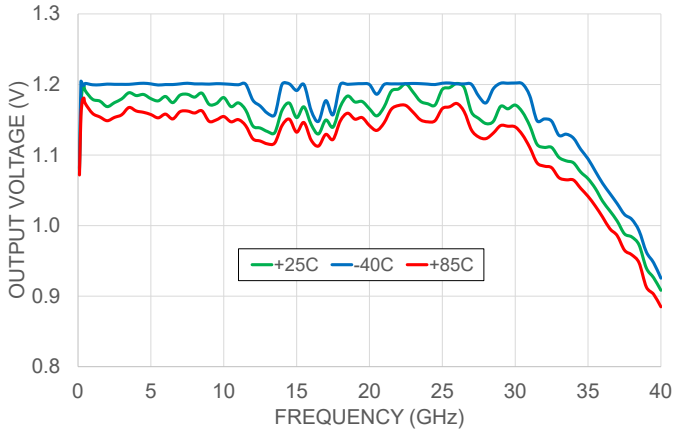

OUTPUT VOLTAGE DEVIATION vs INPUT POWER OVER TEMPERATURE RANGE @ FREQUENCY 100MHz

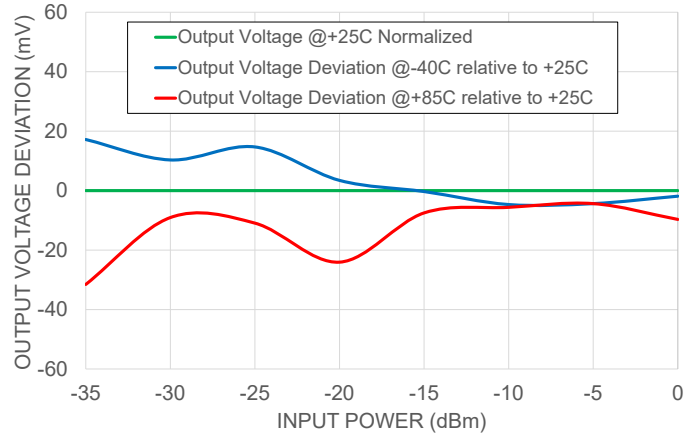

OUTPUT VOLTAGE DEVIATION vs INPUT POWER OVER TEMPERATURE RANGE @ FREQUENCY 20 GHz

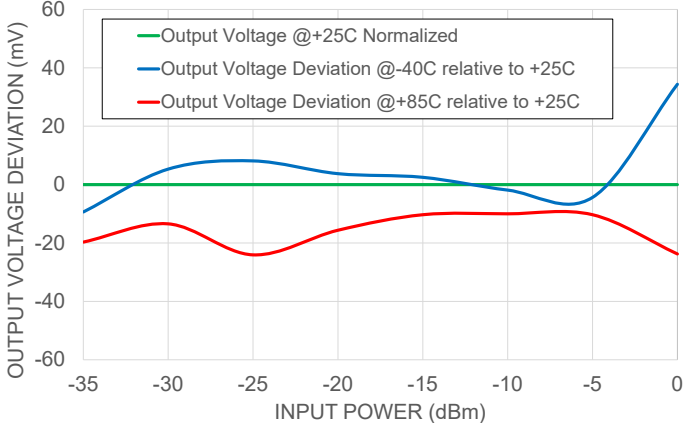

OUTPUT VOLTAGE DEVIATION vs INPUT POWER OVER TEMPERATURE RANGE @ FREQUENCY 40 GHz

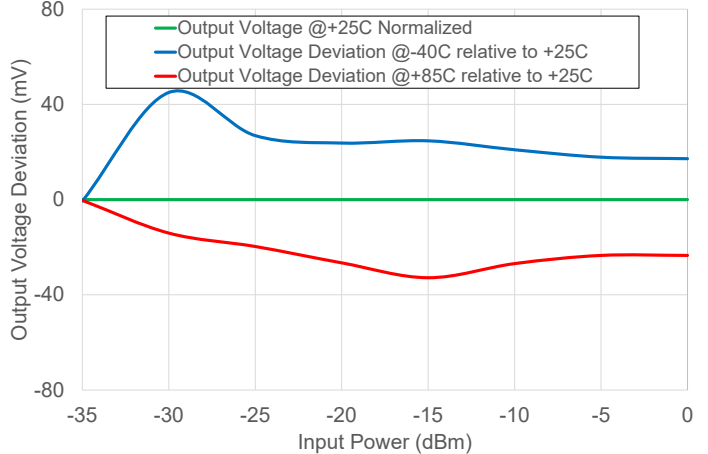

Notes

- A. Performance and quality attributes and conditions not expressly stated in this specification document are intended to be excluded and do not form a part of this specification document.
- B. Electrical specifications and performance data contained in this specification document are based on Mini-Circuit's applicable established test performance criteria and measurement instructions.
- C. The parts covered by this specification document are subject to Mini-Circuits standard limited warranty and terms and conditions (collectively, "Standard Terms"); Purchasers of this part are entitled to the rights and benefits contained therein. For a full statement of the Standard Terms and the exclusive rights and remedies thereunder, please visit Mini-Circuits' website at www.minicircuits.com/MCLStore/terms.jsp



SLOPE Vs INPUT POWER OVER TEMPERATURE RANGE
@ FREQUENCY 100 MHz

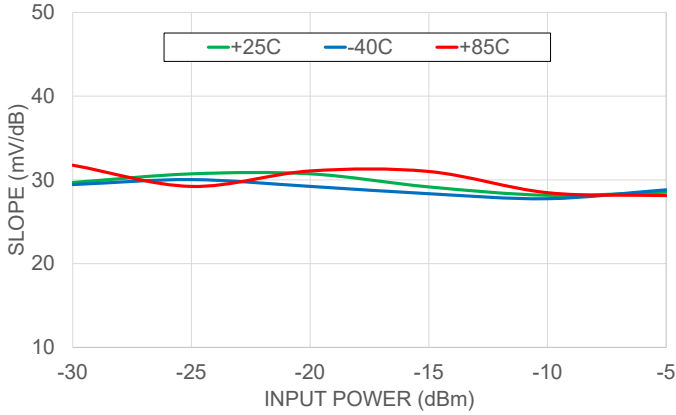

SLOPE Vs INPUT POWER OVER TEMPERATURE RANGE
@ FREQUENCY 20 GHz

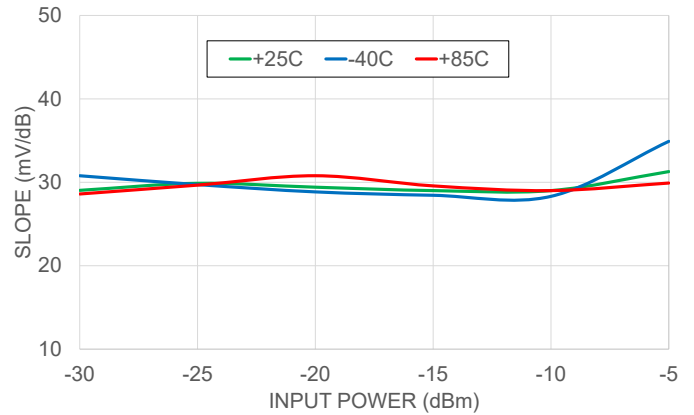

SLOPE Vs INPUT POWER OVER TEMPERATURE RANGE
@ FREQUENCY 40 GHz

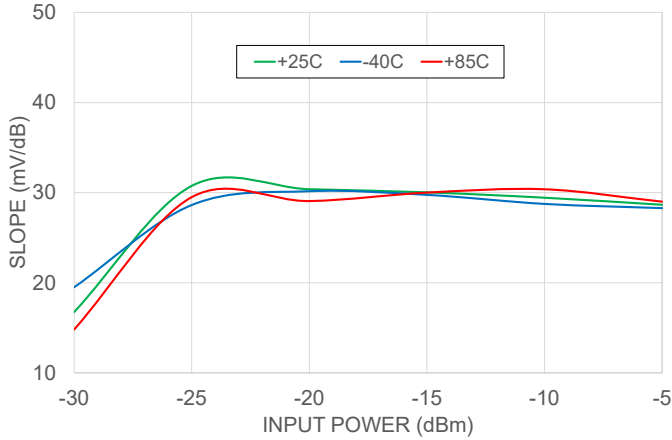

SLOPE Vs FREQUENCY OVER TEMPERATURE RANGE
@ INPUT POWER -30dBm

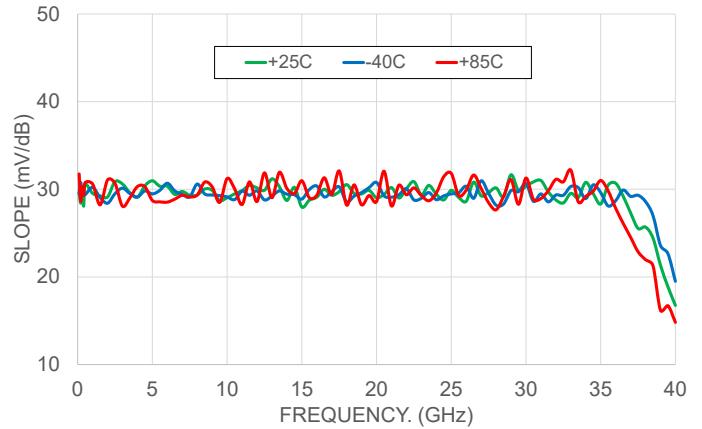

SLOPE Vs FREQUENCY OVER TEMPERATURE RANGE
@ INPUT POWER -20dBm

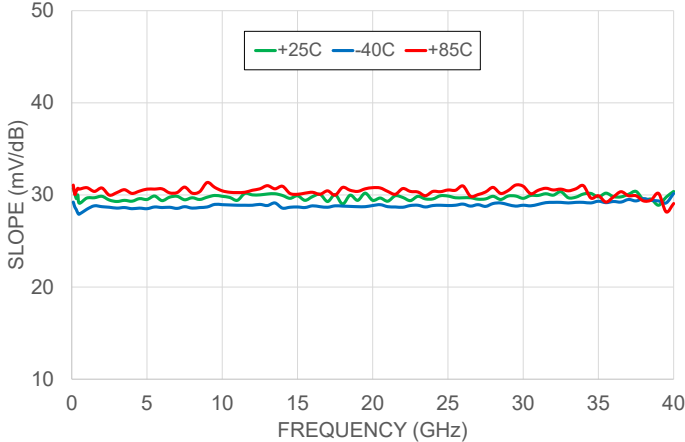

SLOPE Vs FREQUENCY OVER TEMPERATURE RANGE
@ INPUT POWER -5dBm

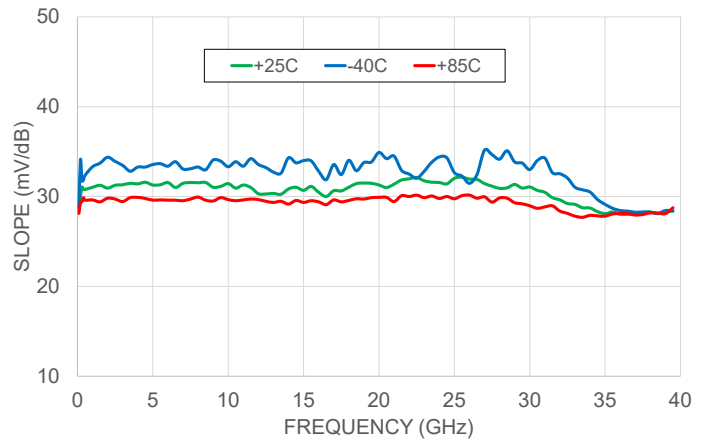

Notes

- A. Performance and quality attributes and conditions not expressly stated in this specification document are intended to be excluded and do not form a part of this specification document.
- B. Electrical specifications and performance data contained in this specification document are based on Mini-Circuit's applicable established test performance criteria and measurement instructions.
- C. The parts covered by this specification document are subject to Mini-Circuits standard limited warranty and terms and conditions (collectively, "Standard Terms"); Purchasers of this part are entitled to the rights and benefits contained therein. For a full statement of the Standard Terms and the exclusive rights and remedies thereunder, please visit Mini-Circuits' website at www.minicircuits.com/MCLStore/terms.jsp



Typical Performance Data

Output Voltage vs. Input Power @ +25°C								
POWER IN (dBm)	@100MHz (V)	@500MHz (V)	@1000MHz (V)	@5000MHz (V)	@10000MHz (V)	@20000MHz (V)	@30000MHz (V)	@40000MHz (V)
-35	0.05	0.15	0.14	0.12	0.14	0.12	0.12	0.00
-30	0.20	0.30	0.28	0.28	0.28	0.26	0.27	0.01
-25	0.35	0.45	0.43	0.43	0.43	0.41	0.42	0.17
-20	0.50	0.60	0.58	0.58	0.58	0.56	0.57	0.32
-15	0.65	0.74	0.73	0.72	0.72	0.71	0.72	0.47
-10	0.80	0.88	0.87	0.87	0.87	0.85	0.86	0.62
-5	0.93	1.02	1.01	1.01	1.01	1.00	1.01	0.77
0	1.08	1.19	1.18	1.18	1.18	1.17	1.17	0.91

Output Voltage (V) vs. Freq over Temperature									
FREQ (MHz)	@ Input Power = -35 dBm			@ Input Power = -20 dBm			@ Input Power = 0 dBm		
	-40°C	+25°C	+85°C	-40°C	+25°C	+85°C	-40°C	+25°C	+85°C
100	0.07	0.05	0.02	0.51	0.50	0.48	1.08	1.08	1.07
500	0.17	0.15	0.13	0.61	0.60	0.59	1.20	1.19	1.17
1000	0.14	0.14	0.11	0.59	0.58	0.57	1.20	1.18	1.16
2000	0.15	0.13	0.09	0.58	0.57	0.56	1.20	1.17	1.15
4000	0.15	0.15	0.11	0.59	0.59	0.57	1.20	1.18	1.16
6000	0.13	0.13	0.13	0.59	0.58	0.57	1.20	1.18	1.16
8000	0.14	0.14	0.12	0.59	0.58	0.57	1.20	1.18	1.16
10000	0.15	0.14	0.10	0.58	0.58	0.56	1.20	1.18	1.15
12000	0.11	0.09	0.09	0.56	0.55	0.53	1.18	1.14	1.12
14000	0.13	0.12	0.09	0.57	0.57	0.55	1.20	1.16	1.14
16000	0.10	0.11	0.09	0.55	0.55	0.53	1.16	1.14	1.12
18000	0.14	0.11	0.11	0.57	0.57	0.55	1.20	1.17	1.15
20000	0.11	0.12	0.10	0.57	0.56	0.55	1.20	1.17	1.14
22000	0.15	0.13	0.12	0.59	0.59	0.58	1.20	1.19	1.17
24000	0.14	0.12	0.10	0.57	0.57	0.55	1.20	1.17	1.15
26000	0.15	0.15	0.12	0.60	0.59	0.57	1.20	1.20	1.17
28000	0.12	0.09	0.10	0.55	0.54	0.53	1.17	1.14	1.12
30000	0.13	0.12	0.09	0.59	0.57	0.55	1.20	1.17	1.14
32000	0.10	0.08	0.04	0.54	0.52	0.50	1.15	1.11	1.08
34000	0.10	0.05	0.04	0.53	0.51	0.48	1.12	1.09	1.06
36000	0.05	0.00	0.00	0.49	0.46	0.43	1.06	1.03	1.01
38000	0.00	0.00	0.00	0.44	0.40	0.38	1.01	0.98	0.96
40000	0.00	0.00	0.00	0.35	0.32	0.29	0.93	0.91	0.88



Typical Performance Data

Input Power Deviation from Ideal vs. Input Power @ +25°C								
@ 100 MHz					@ 10000 MHz			
Pin Measured	Vout, Measured (V)	Vout, Ideal (V)	Pin, ideal (dBm)	Deviation from ideal (dB)	Vout, Measured (V)	Vout, Ideal (V)	Pin, ideal (dBm)	Deviation from ideal (dB)
-35	0.05	0.05	-35.14	-0.14	0.14	0.13	-34.86	0.14
-30	0.20	0.20	-30.11	-0.11	0.28	0.28	-30.01	-0.01
-25	0.35	0.35	-25.10	-0.10	0.43	0.43	-25.06	-0.06
-20	0.50	0.50	-19.72	0.28	0.58	0.58	-19.98	0.02
-15	0.65	0.64	-14.71	0.29	0.72	0.72	-14.98	0.02
-10	0.80	0.79	-9.85	0.15	0.87	0.87	-10.15	-0.15
-5	0.93	0.94	-5.18	-0.18	1.01	1.02	-5.41	-0.41
0	1.08	1.09	-0.20	-0.20	1.18	1.17	0.46	0.46

Input Power Deviation from Ideal vs. Input Power @ +25°C								
@ 20000 MHz					@ 30000 MHz			
Pin Measured	Vout, Measured (V)	Vout, Ideal (V)	Pin, ideal (dBm)	Deviation from ideal (dB)	Vout, Measured (V)	Vout, Ideal (V)	Pin, ideal (dBm)	Deviation from ideal (dB)
-35	0.12	0.12	-34.84	0.16	0.12	0.12	-35.08	-0.08
-30	0.26	0.26	-30.03	-0.03	0.27	0.27	-29.99	0.01
-25	0.41	0.41	-25.04	-0.04	0.42	0.42	-24.92	0.08
-20	0.56	0.56	-19.94	0.06	0.57	0.57	-19.85	0.15
-15	0.71	0.71	-15.11	-0.11	0.72	0.72	-15.01	-0.01
-10	0.85	0.86	-10.14	-0.14	0.86	0.87	-10.18	-0.18
-5	1.00	1.00	-5.31	-0.31	1.01	1.01	-5.22	-0.22
0	1.17	1.15	0.42	0.42	1.17	1.16	0.22	0.22

Input Power Deviation from Ideal vs. Input Power @ +25°C				
@ 40000 MHz				
Pin Measured	Vout, Measured (V)	Vout, Ideal (V)	Pin, ideal (dBm)	Deviation from ideal (dB)
-35	0.00	-0.13	-30.62	4.38
-30	0.01	0.02	-30.20	-0.20
-25	0.17	0.17	-25.01	-0.01
-20	0.32	0.32	-19.90	0.10
-15	0.47	0.47	-14.83	0.17
-10	0.62	0.62	-9.84	0.16
-5	0.77	0.77	-4.97	0.03
0	0.91	0.92	-0.24	-0.24

Typical Performance Data

POWER IN (dBm)	Slope (mV/dB) vs Input Power Over Temperature								
	Range @ Freq 100MHz			Range @ Freq 2000MHz			Range @ Freq 4000MHz		
	-40°C	+25°C	+85°C	-40°C	+25°C	+85°C	-40°C	+25°C	+85°C
-30	29.44	29.69	31.75	30.79	29.03	28.60	19.50	16.75	14.81
-25	30.03	30.72	29.22	29.72	29.88	29.66	28.63	30.75	29.50
-20	29.22	30.73	31.07	28.85	29.41	30.79	30.16	30.38	29.07
-15	28.35	29.16	31.01	28.44	29.01	29.57	29.76	30.04	30.01
-10	27.75	28.16	28.47	28.32	29.00	29.00	28.75	29.44	30.38
-5	28.82	28.53	28.13	34.91	31.29	29.91	28.28	28.66	29.00

FREQ (MHz)	Slope (mV/dB) vs Frequency Over Temperature								
	@ Input Power = -30dBm			@ Input Power = -20dBm			@ Input Power = -5dBm		
	-40°C	+25°C	+85°C	-40°C	+25°C	+85°C	-40°C	+25°C	+85°C
100	29.44	29.69	31.75	29.22	30.73	31.07	28.82	28.53	28.13
500	29.38	30.57	30.75	27.91	29.10	30.63	32.35	30.79	29.60
1000	30.22	29.53	30.60	28.44	29.66	30.79	33.32	31.04	29.63
2000	28.41	29.13	31.07	28.72	29.85	30.76	34.38	30.94	29.82
4000	29.13	29.10	30.32	28.51	29.32	30.16	33.29	31.41	29.91
6000	30.69	30.35	28.53	28.63	29.38	30.66	33.38	31.57	29.60
8000	30.60	29.35	29.35	28.57	29.69	30.19	33.29	31.54	29.94
10000	29.13	29.03	31.22	28.94	29.85	30.44	33.32	31.44	29.66
12000	29.82	30.16	28.60	28.88	30.01	30.51	33.57	30.32	29.66
14000	29.44	28.72	30.10	28.57	29.94	30.94	34.32	30.85	29.16
16000	30.38	29.10	29.32	28.82	29.82	30.29	32.82	30.47	29.41
18000	28.57	30.53	28.19	28.79	29.01	30.82	34.04	31.04	29.57
20000	30.79	29.03	28.60	28.85	29.41	30.79	34.91	31.29	29.91
22000	30.07	30.07	29.38	28.66	29.72	30.69	32.50	31.97	30.00
24000	28.82	29.44	29.57	28.85	29.57	30.38	34.41	31.57	29.78
26000	30.35	28.63	29.91	29.01	29.69	30.98	31.47	31.94	30.16
28000	28.19	30.16	27.66	29.07	29.85	30.82	34.16	30.91	29.85
30000	30.66	30.35	31.29	28.88	29.63	30.94	33.00	31.07	28.97
32000	29.35	28.78	31.13	29.19	29.97	30.54	32.54	29.63	28.38
34000	28.94	30.79	29.19	29.19	30.10	31.01	30.50	28.72	27.91
36000	28.69	30.69	27.85	29.29	29.82	29.79	28.44	28.03	28.10
38000	28.60	25.69	21.97	29.60	29.47	29.35	28.25	28.28	28.19
40000	19.50	16.75	14.81	30.16	30.38	29.07	28.28	28.66	29.00

Typical Performance Data

Output Voltage Deviation (mV) vs. Input Power at Frequency = 100 MHz			
POWER IN (dBm)	Temp = +25C	Output Voltage Deviation @-40°C relative to +25°C	Output Voltage Deviation @+85°C relative to +25°C
-35	0	17.19	-31.57
-30	0	10.31	-9.06
-25	0	14.69	-10.94
-20	0	3.44	-24.07
-15	0	-0.31	-7.50
-10	0	-4.69	-5.63
-5	0	-4.38	-4.38
0	0	-1.88	-9.69

Output Voltage Deviation (mV) vs. Input Power at Frequency = 20000 MHz			
POWER IN (dBm)	Temp = +25C	Output Voltage Deviation @-40°C relative to +25°C	Output Voltage Deviation @+85°C relative to +25°C
-35	0	-9.38	-19.69
-30	0	5.31	-13.44
-25	0	8.13	-24.07
-20	0	3.75	-15.63
-15	0	2.50	-10.31
-10	0	-1.88	-10.00
-5	0	-4.38	-10.31
0	0	34.38	-9.69

Output Voltage Deviation (mV) vs. Input Power at Frequency = 40000 MHz			
POWER IN (dBm)	Temp = +25C	Output Voltage Deviation @-40°C relative to +25°C	Output Voltage Deviation @+85°C relative to +25°C
-35	0	-0.63	-0.31
-30	0	45.01	-14.06
-25	0	26.88	-19.69
-20	0	23.75	-26.57
-15	0	24.69	-32.82
-10	0	20.94	-26.88
-5	0	17.81	-23.44
0	0	17.19	-23.44

VSWR vs. Frequency over Temperature			
FREQ (MHz)	-40°C (:1)	+25°C (:1)	+85°C (:1)
100	1.05	1.05	1.05
500	1.07	1.07	1.07
1000	1.09	1.10	1.10
2000	1.21	1.20	1.21
4000	1.39	1.41	1.42
6000	1.46	1.45	1.47
8000	1.37	1.39	1.40
10000	1.78	1.76	1.77
12000	2.27	2.31	2.37
14000	2.62	2.59	2.59
16000	2.49	2.51	2.56
18000	2.31	2.20	2.15
20000	1.98	1.93	1.94
22000	1.63	1.59	1.52
24000	1.75	1.64	1.68
26000	1.78	1.88	1.86
28000	2.58	2.28	2.21
30000	2.34	2.30	2.17
32000	2.10	1.92	1.93
34000	1.50	1.43	1.41
36000	1.17	1.17	1.25
38000	1.46	1.52	1.53
40000	2.22	2.09	2.13

Typical Performance Curves

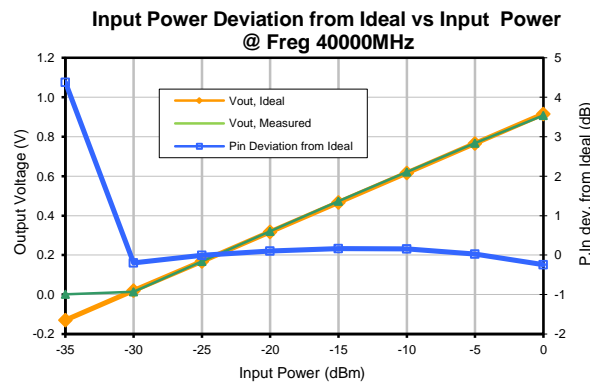
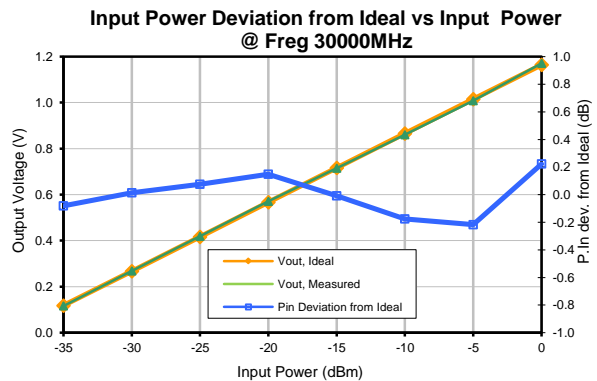
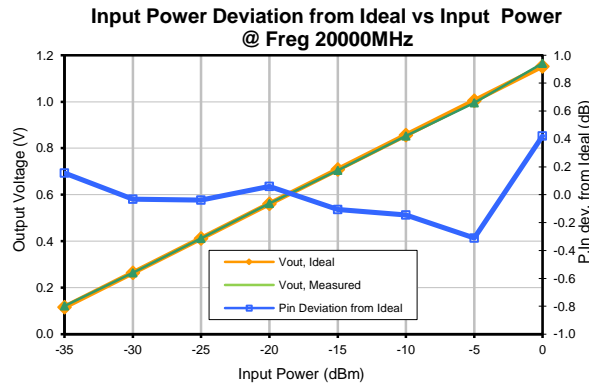
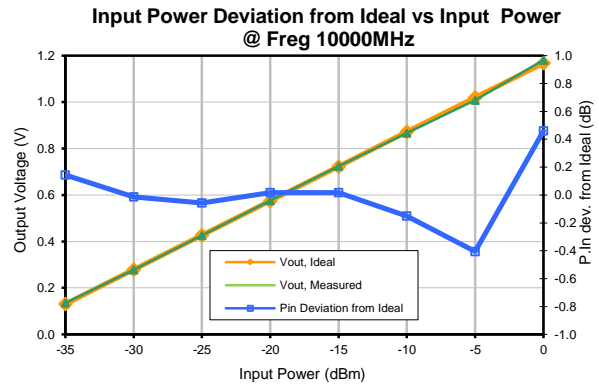
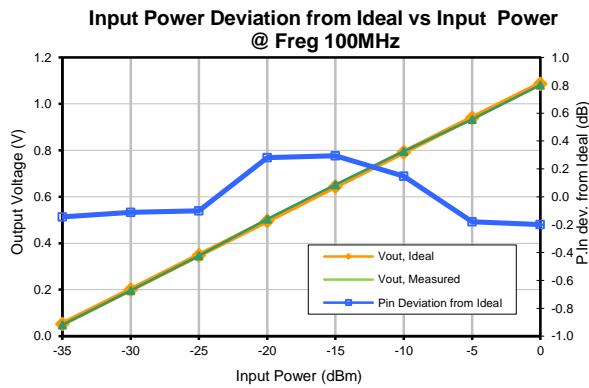
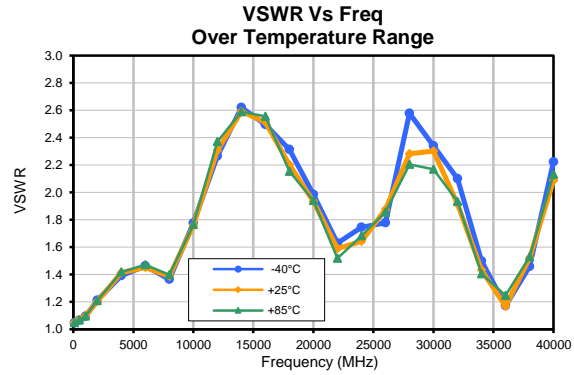
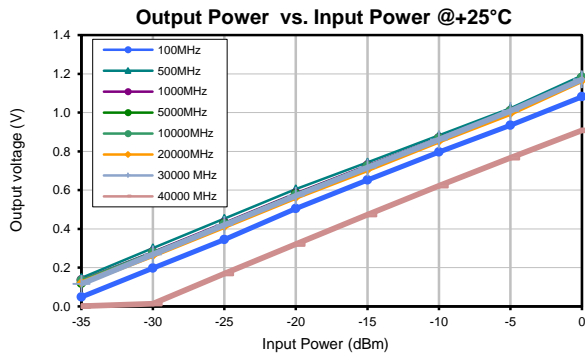

Typical Performance Curves

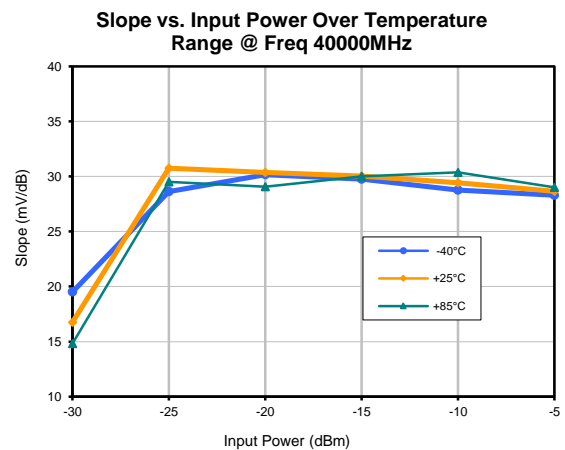
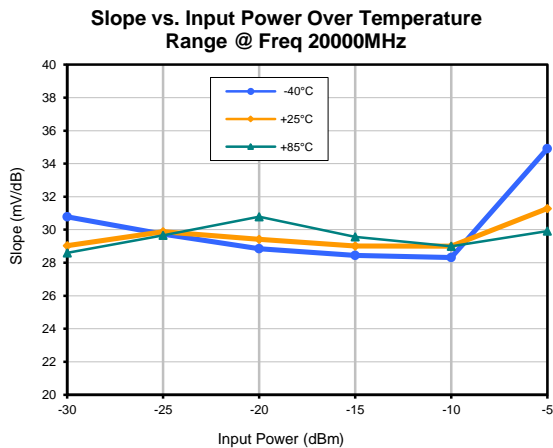
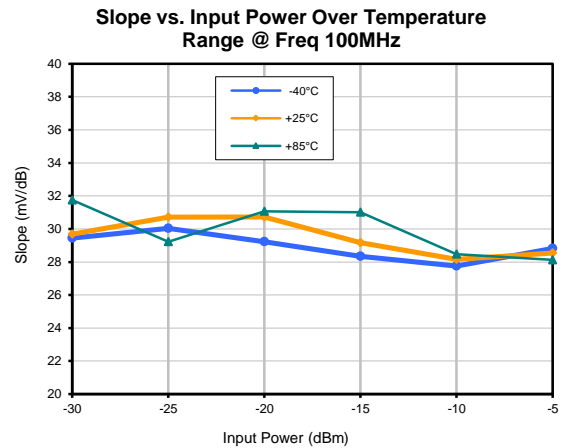
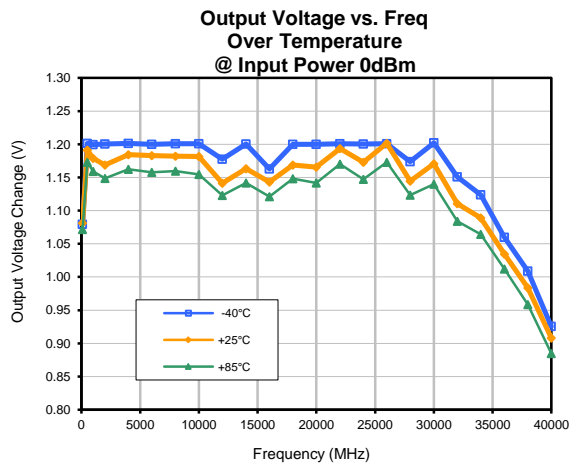
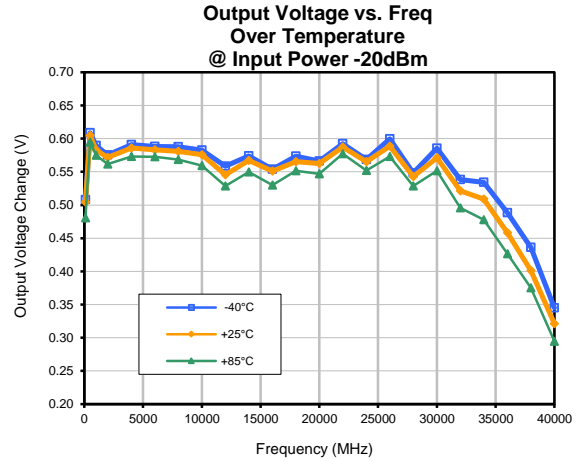
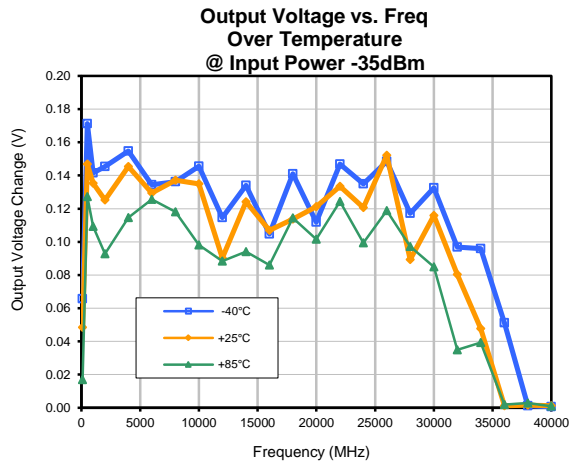

Typical Performance Curves

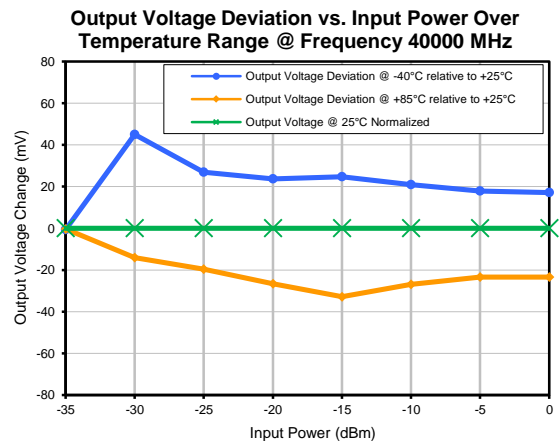
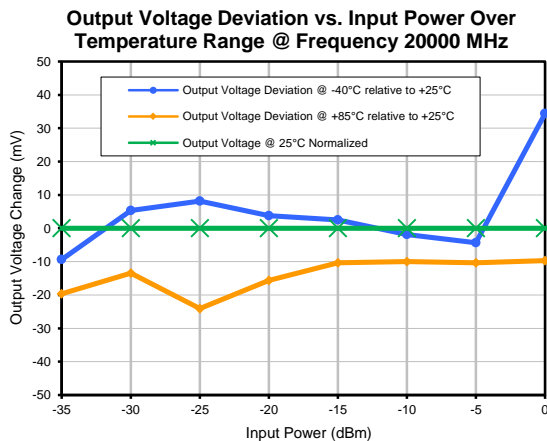
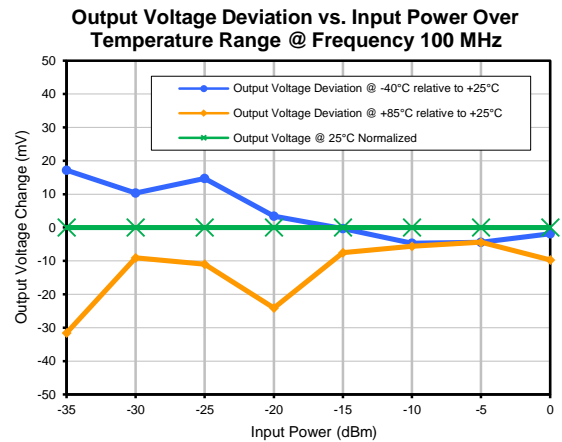
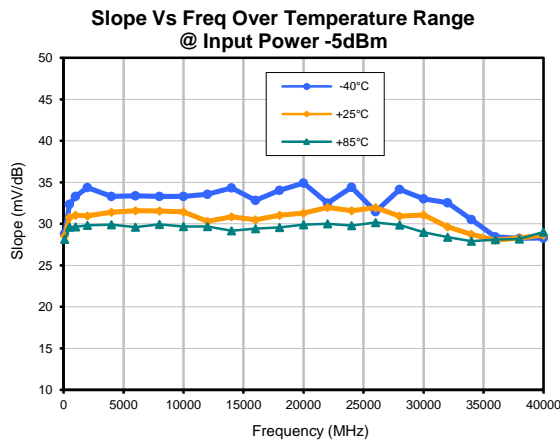
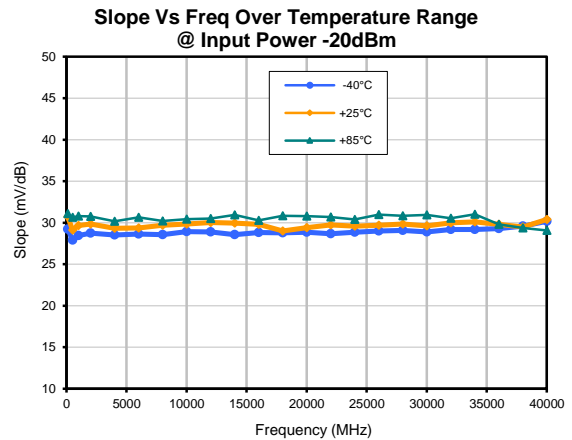
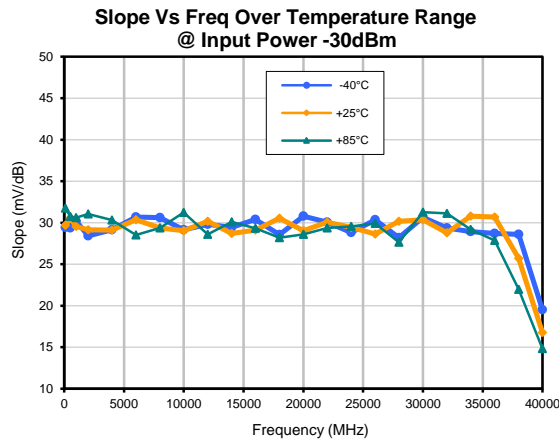

Outline Dimensions

AV2578-4

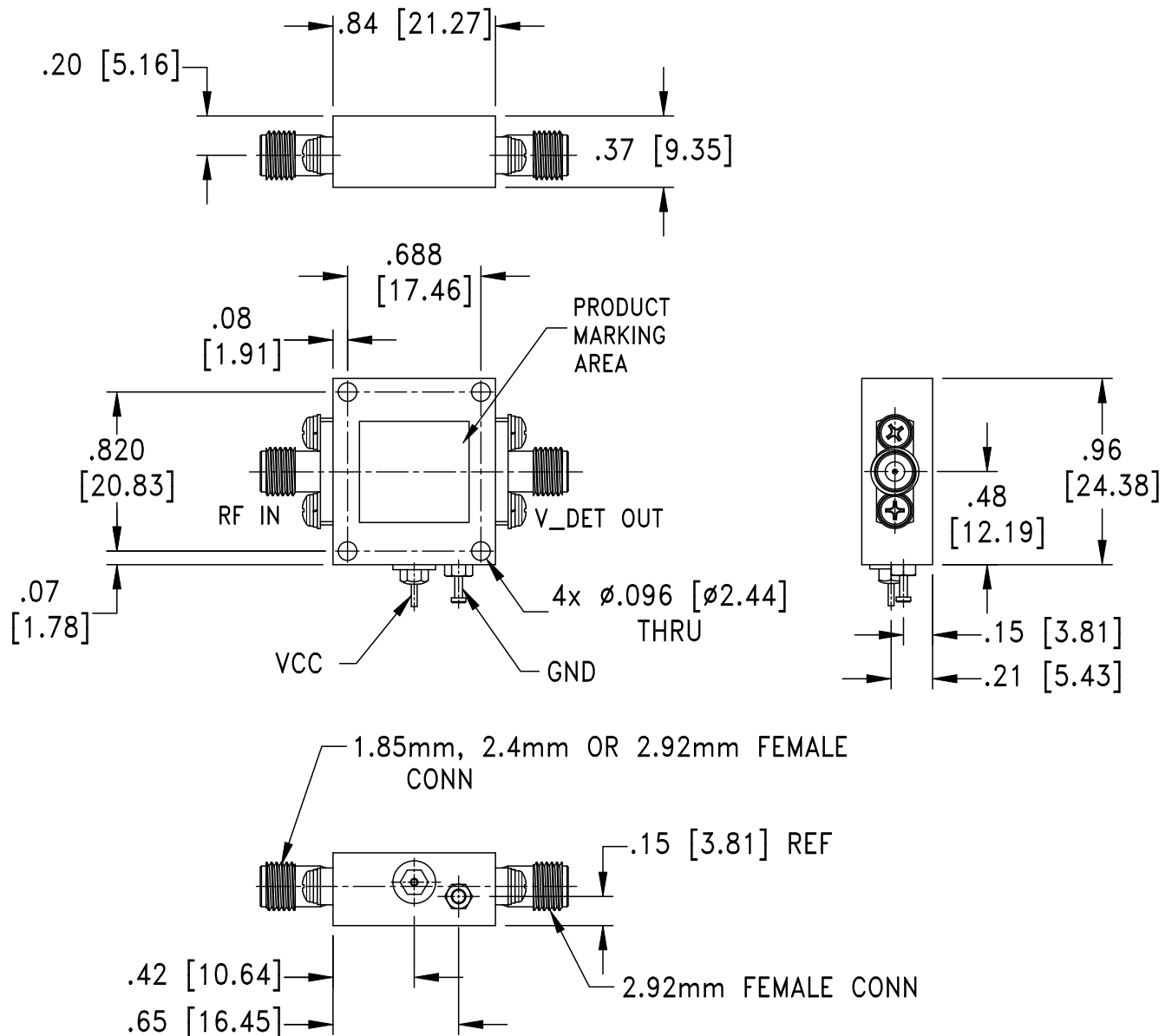

Weight: 45 grams

Dimensions are in inches (mm). Tolerances: 2 Pl. $\pm .03$; 3 Pl. $\pm .015$

Notes:

1. Case material: Brass alloy
2. Case finish: Gold plating 20 μ inches, over Nickel plating 100 μ inches.

Mini-Circuits
ISO 9001 ISO 14001 CERTIFIED

ALL NEW
minicircuits.com

P.O. Box 350166, Brooklyn, New York 11235-0003 (718) 934-4500 Fax (718) 332-4661 For detailed performance specs & shopping online see Mini-Circuits web site



The Design Engineers Search Engine Provides ACTUAL Data Instantly From MINI-CIRCUITS At: www.minicircuits.com

RF/IF MICROWAVE COMPONENTS



All Mini-Circuits products are manufactured under exacting quality assurance and control standards, and are capable of meeting published specifications after being subjected to any or all of the following physical and environmental test.

Specification	Test/Inspection Condition	Reference/Spec
Operating Temperature	-40° to 85°C	Individual Model Data Sheet
Storage Temperature	-55° to 100° C Ambient Environment	Individual Model Data Sheet
Barometric Pressure	100,000 Feet	MIL-STD-202, Method 105, Condition D
Humidity	90% RH, 65°C Units may require bake-out after humidity to restore full performance.	MIL-STD-202, Method 103
Thermal Shock	-65° to 125°C, 5 cycles	MIL-STD-202, Method 107, Condition B
Vibration (High Frequency)	20g peak, 10-2000 Hz, 12 times in each of three perpendicular directions (total 36)	MIL-STD-202, Method 204, Condition D
Mechanical Shock	100g, 6ms sawtooth, 3 shocks each direction 3 axes (total 18)	MIL-STD-202, Method 213, Condition I