



## USB & ETHERNET

# 9-Port Mesh Network Emulator ZTMN-0995C-S

50Ω 600 to 7200 MHz Rack-Mount SMA Female

### THE BIG DEAL

- 9 fully interconnected test ports
- Compact rack-mountable chassis, 3U height
- 95 dB programmable attenuation per path
- Configure automated sweep / hop / fading sequences
- Ethernet & USB control

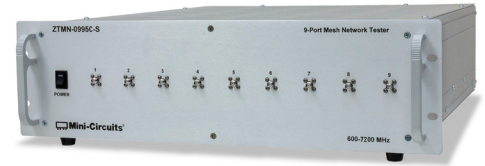

Generic photo used for illustration purposes only

### APPLICATIONS

- 5G FR1 / WiFi 6E / IoT / Zigbee device testing
- ISM band fire & security monitoring
- Production, R&D, qualification testing
- Smart home & energy monitoring systems
- Test & measurement systems

### FUNCTIONAL BLOCK DIAGRAM

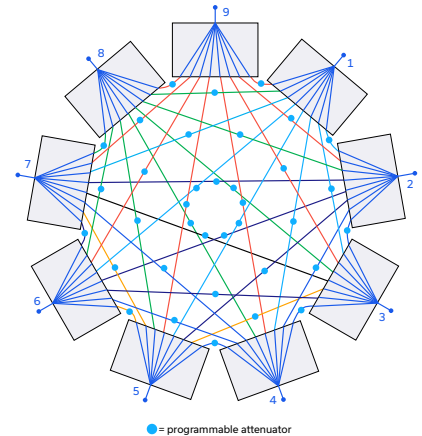

### PRODUCT OVERVIEW

Mini-Circuits' ZTMN series mesh network emulators are multi-port test systems with independently variable attenuation on each internal path. This concept allows simulation of a "real-world" mesh communication network within the confined space of a production environment. Path loss can be varied independently between any pair of devices on the network without affecting any other combination of devices, allowing simulation of a complex range of test cases.

ZTMN-0995C-S is a 9-port mesh covering the 0.6-7.2 GHz bands, with 0 to 95 dB attenuation range on each of the internal paths. The model is housed in a compact, 3U height, 19-inch rack chassis with all RF connectors on the front panel. The ZTMN series also supports larger mesh network combinations, custom attenuation and frequency ranges available on request.

The system can be controlled via USB or Ethernet (supporting SSH, HTTP & Telnet protocols). Full software support is provided, including our user-friendly GUI application for Windows and a full API with programming instructions for Windows and Linux environments (both 32-bit and 64-bit systems).

### KEY FEATURES

Feature	Advantages
Wide attenuation range	Independently controllable 0-95 dB attenuators on each path allow simulation of a wide range of test scenarios including receiver sensitivity, device / base-station handovers, device failures, and interference effects.
Wide bandwidth	Operation from 0.5-7.2 GHz incorporates most of the key commercial wireless mesh network applications, including WiFi 6E, 5G FR1 and Zigbee.
Rack-mount chassis	Compact 3U height, 19" rack-mountable chassis suits integration in automated production test environments.
Secure Ethernet communication	Support for SSH (Secure Shell protocol) provides a means for secure communication over Ethernet networks with strict security policies. HTTP & Telnet communication via Ethernet are also supported.

REV. A  
ECO-022251  
ZTMN-0995C-S  
MCL NY  
240627





### ELECTRICAL SPECIFICATIONS AT +25°C

Parameter	Conditions	Min.	Typ.	Max.	Units
Frequency Range		600		7200	MHz
Insertion Loss <sup>1</sup>	600-3000 MHz		26	29	dB
	3000-6000 MHz		30	33	
	6000-7200 MHz		33	36	
Isolation	Direct path (600-7200 MHz) <sup>2</sup>		110		dB
	Leakage path (600-7200 MHz) <sup>3</sup>		60		
Return Loss			15		dB
Input Power	Per port			+25	dBm
Attenuation Range	Per Path	0		95	dB
Attenuation Steps	0 – 90 dB Range		0.25		dB

1. Path loss on the direct path between 2 ports when the attenuator in path is at 0 dB
2. Path loss on the direct path between 2 ports with all attenuators at max attenuation
3. Path loss on the leakage path between 2 ports with the 2 attenuators in the leakage path at 0 dB and all others at max attenuation

### MESH ISOLATION CHARACTERISTIC

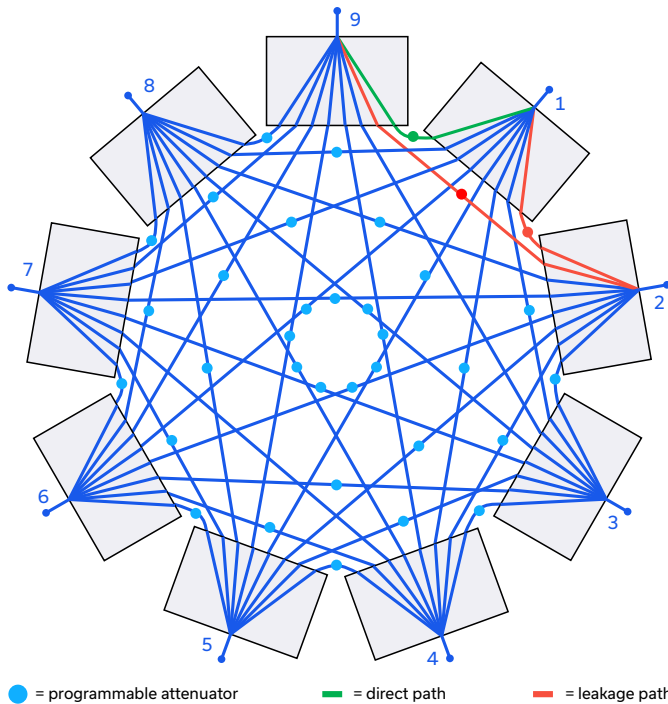

The green path in the diagram opposite is the direct path between ports 1 & 2. In an ideal mesh this would be the only route between these 2 ports. The insertion loss (IL) on the green direct path is approximately as below, when the attenuator highlighted in green is set to 0 dB:

$$IL_{DIRECT} = IL_{SPLITTER} + IL_{ATTENUATOR} + IL_{SPLITTER}$$

The red path highlights an indirect, leakage path which also exists between ports 1 & 2 due to the finite isolation of the splitter / combiner component. A number of similar leakage paths also exist across the output ports of the other splitter / combiner components within the mesh. The worst-case isolation (ISO) of the red leakage path is approximately as below, when the attenuators highlighted in red are set to 0 dB:

$$ISO_{LEAKAGE} = IL_{SPLITTER} + IL_{ATTENUATOR} + ISO_{SPLITTER} + IL_{ATTENUATOR} + IL_{SPLITTER}$$

Mini-Circuits minimizes the leakage paths by design; a well-designed splitter / combiner component can offer in the order of 20 dB isolation over a wide bandwidth. It is not possible to remove entirely the leakage paths but their effects can be mitigated during operation of the mesh through careful choice of the programmable attenuation values in path. Mini-Circuits' recommendations are:

1. Terminate any unused external ports around the mesh to ensure the best impedance match throughout.
2. Set all programmable attenuators to their maximum values (95 dB) initially to ensure all direct and leakage paths are isolated, then reduce the attenuation on the specific paths required by the test scenario.
3. When leakage paths are affecting measurements, consider increasing the value on all internal programmable attenuators to minimize their significance. Every 1 dB increase in insertion loss on all direct paths, leads to a 2 dB increase on all indirect paths.

**CONTROL INTERFACES**

Ethernet Control	Supported Protocols	TCP / IP, SSH, HTTP, Telnet, DHCP, UDP (limited)
	Max Data Rate	100 Mbps (100Base-T Full Duplex)
USB Control	Supported Protocols	HID – High Speed
	Min Communication Time <sup>5</sup>	400 μs typ

5. Based on the polling interval of the USB HID protocol (125 μs with 1024 bytes per packet) and no other significant CPU or USB activity

**SOFTWARE & DOCUMENTATION**

Mini-Circuits' full software and support package including user guide, Windows GUI, API, programming manual and examples can be downloaded free of charge (refer to the last page for the download path).

A comprehensive set of software control options is provided:

- GUI for Windows – Simple software interface for control via Ethernet and USB
- Programming / automation via Ethernet
  - Complete set of control commands which can be sent via any supported protocol – simple to implement in the majority of modern programming environments
- Programming / automation via USB
  - DLL files provide a full API for Windows with a set of intuitive functions which can be implemented in any programming environment supporting .Net Framework or ActiveX
  - Direct USB programming is possible in any other environment (not supporting .Net or ActiveX)

Please contact [testsolutions@minicircuits.com](mailto:testsolutions@minicircuits.com) for support

**MINIMUM SYSTEM REQUIREMENTS**

Hardware	Intel i3 (or equivalent) or later
GUI (USB or Ethernet Control)	Windows 7 or later
USB API DLL	Windows 7 or later with support for Microsoft .Net Framework or ActiveX
USB Direct Programming	Windows 7 or later; Linux
Ethernet	Windows, Linux or macOS with Ethernet TCP / IP support

**PROGRAMMING COMMANDS**

The key ASCII / SCPI commands for control of the system for control via the Ethernet or USB API are summarized below (refer to the programming manual for full details):

Command / Query	Description
:MN?	Read model name
:SN?	Read serial number
:FIRMWARE?	Read firmware version
:[address]:[channels]:SETATT:[value]	<ul style="list-style-type: none"> <li>• Set attenuation:</li> <li>• [address] = Address of the attenuator module (refer to the Attenuator Path Map table)</li> <li>• [channels] = Channel number (1 to 8) within the 8-channel attenuator module. Multiple channels can be listed in a string, separated by colon (":").</li> <li>• [value] = Attenuation value to set (from 0 to 95 dB)</li> <li>• Example:</li> <li>• 01:CHAN:1:2:3:SETATT:10.25</li> </ul>
:[address]:[channels]:ATT?	<ul style="list-style-type: none"> <li>• Return a single attenuator value:</li> <li>• [address] = Address of the attenuator module (refer to the Attenuator Path Map table)</li> <li>• [channels] = Channel number (1 to 8) within the 8-channel attenuator module</li> <li>• Example:</li> <li>• 01:CHAN:1:ATT?</li> </ul>



## GRAPHICAL USER INTERFACE (GUI) FOR WINDOWS

- Connect via USB or Ethernet
- Run GUI in demo mode to evaluate software without a hardware connection

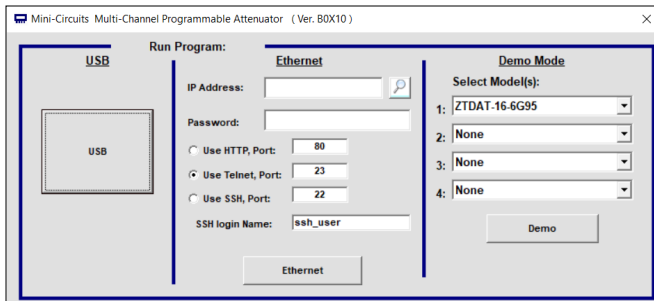

- View and set all attenuator values, independently or in groups
- Configure automated sweep / hop / fading sequences
- Apply custom port / path names
- Configure system and Ethernet settings

The screenshot displays the main GUI interface. On the left, a sidebar shows system information: Model Name (ZTMN-0995C-S), Serial Number (02306060135), System Name (Attenuator System), Channels (36), User Name (Admin), and Connection (USB). A 'Set Attenuation' panel shows 'Single Channel' selected with a value of 55.00 dB. The 'Channels' table lists 9 channels with their respective paths and attenuation values. The 'Timing' panel shows 'Sequence #1' and 'Sequence #2' configured for sweep mode with start/stop dB and step values.

ZTMN-0995C-S	A	B	C	D
01	Path 8<>3   22.00	Path 8<>6   95.00	Path 8<>7   95.00	Path 8<>9   95.00
02	Path 9<>3   95.00	Path 9<>4   95.00	Path 9<>6   55.00	Path 9<>7   95.00
03	Path 5<>7   95.00	Path 6<>7   95.00	Path 7<>3   95.00	Path 8<>4   95.00
04	Path 2<>8   95.00	Path 6<>1   95.00	Path 8<>1   95.00	Path 1<>9   95.00
05	Path 2<>9   55.00	Path 5<>2   44.00	Path 5<>9   95.00	Path 5<>8   95.00
06	Path 6<>5   95.00	Path 5<>3   95.00	Path 2<>3   95.00	Path 1<>7   95.00
07	Path 1<>2   95.00	Path 1<>4   95.00	Path 1<>3   95.00	Path 1<>5   95.00
08	Path 2<>4   95.00	Path 3<>6   95.00	Path 2<>7   95.00	Path 2<>6   95.00
09	Path 4<>7   95.00	Path 3<>4   95.00	Path 4<>6   95.00	Path 5<>4   95.00



## TYPICAL PERFORMANCE GRAPHS

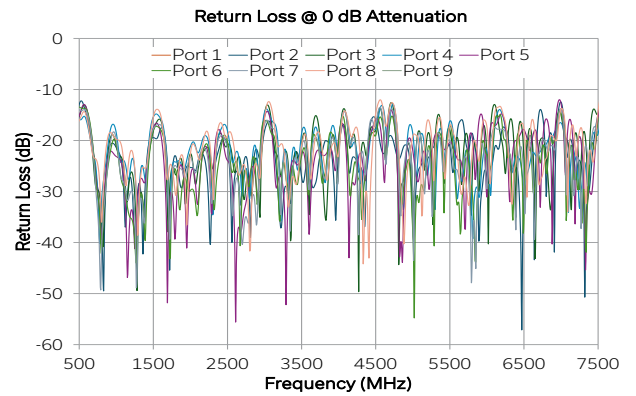
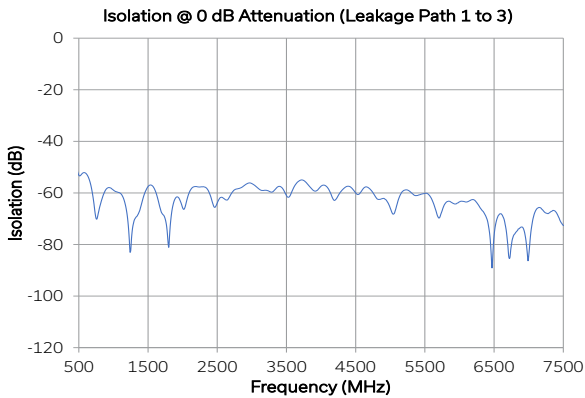
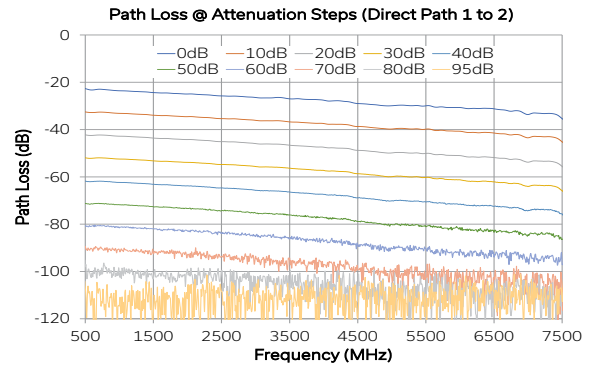
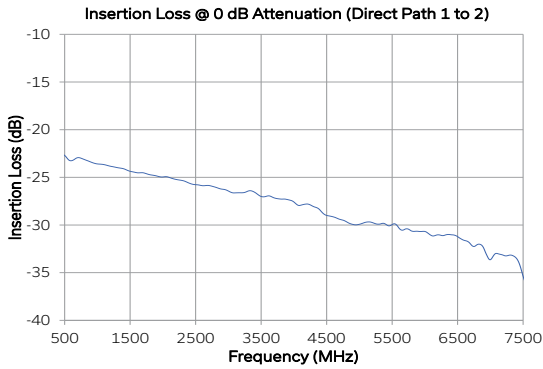



## USB & ETHERNET

# 9-Port Mesh Network Emulator **ZTMN-0995C-S**

50Ω 600 to 7200 MHz Rack-Mount SMA Female

### ABSOLUTE MAXIMUM RATINGS<sup>6</sup>

Parameter	Conditions	Limits	Units
Temperature	Operating	0 to +50	°C
	Storage	-20 to +60	
Input Power (No Damage)	Per port	+25	dBm

6. Permanent damage may occur if any of these limits are exceeded. Operating in the range between operating power limits and absolute maximum ratings for extended periods of time may result in reduced life and reliability.

### POWER SUPPLY

Power Supply	AC mains input: 100-240 V, 50 / 60 Hz
Fuse	2A, 250V rating
Power Consumption	85W maximum

### FUNCTIONAL BLOCK DIAGRAM

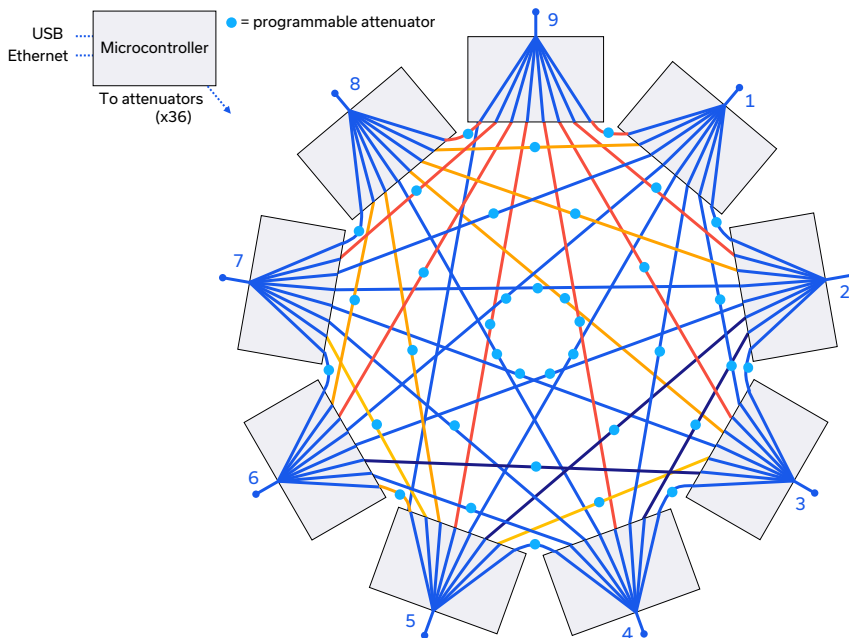

### CONNECTIONS

Port	Connector
1 to 9	SMA female
USB	USB type B
Ethernet / LAN	RJ45
AC Input	IEC C14 inlet

### ATTENUATOR / PATH MAP

- The mesh is constructed using nine 4-channel programmable attenuator blocks, addressed 01 to 09
- Each of the 4 channels within a block controls the path loss between a pair of ports, as shown below

	Channel 1 (A)	Channel 2 (B)	Channel 3 (C)	Channel 4 (D)
Att 01	1 <> 5	2 <> 5	3 <> 5	4 <> 5
Att 02	2 <> 6	3 <> 6	4 <> 6	5 <> 6
Att 03	3 <> 7	4 <> 7	5 <> 7	6 <> 7
Att 04	4 <> 8	5 <> 8	6 <> 8	7 <> 8
Att 05	5 <> 9	6 <> 9	7 <> 9	8 <> 9
Att 06	3 <> 4	2 <> 4	1 <> 4	4 <> 9
Att 07	2 <> 3	1 <> 3	3 <> 9	3 <> 8
Att 08	1 <> 2	2 <> 9	2 <> 8	2 <> 7
Att 09	1 <> 9	1 <> 8	1 <> 7	1 <> 6





## OUTLINE DRAWING

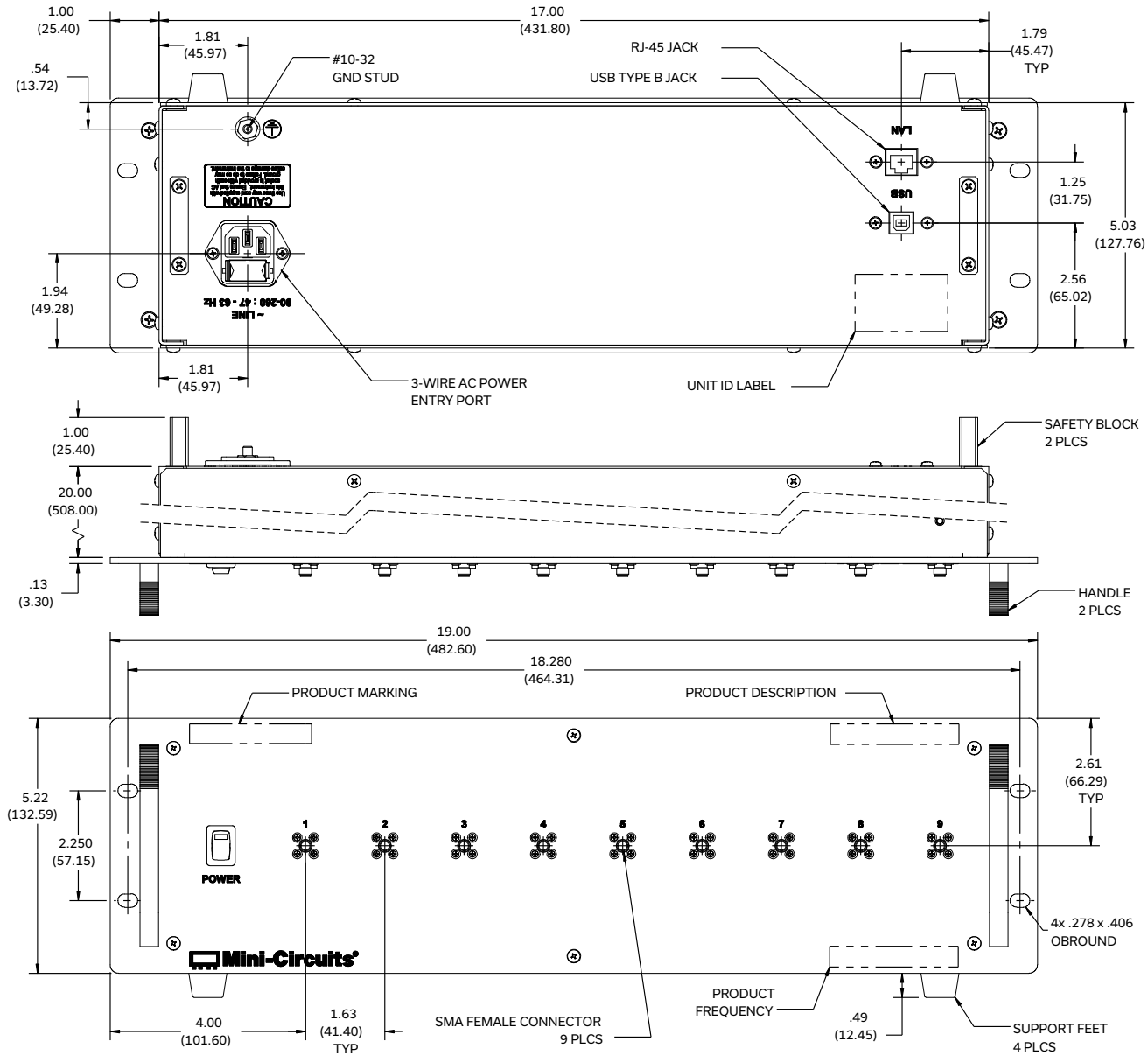

Weight: 13520 grams.

Dimensions are in inches (mm). Tolerances: 2 Pl.±.03 inch; 3 Pl.±.015 inch.

## PRODUCT MARKING

Product Marking: ZTMN-0995C-S

Product Description: 9-Port Mesh Network Test Drawer

Product Frequency: 600 - 7200 MHz

Unit ID Label: Serial number and other identification marks

\*Marking may contain other features or characters for internal lot control





## USB & ETHERNET



# 9-Port Mesh Network Emulator **ZTMN-0995C-S**





50Ω 600 to 7200 MHz Rack-Mount SMA Female

DETAILED MODEL INFORMATION IS AVAILABLE ON OUR WEBSITE [CLICK HERE](#)

Case Style	YT2786
Software, User Guide & Programming Manual	<a href="http://www.minicircuits.com/softwaredownload/multiatt.html">www.minicircuits.com/softwaredownload/multiatt.html</a>
Environmental Rating	ENV55
Regulatory Compliance	<p>Refer to our website for compliance methodologies and qualifications</p>  <p><a href="http://www.minicircuits.com/quality/environmental_introduction.html">www.minicircuits.com/quality/environmental_introduction.html</a></p>

Contact Us: [testsolutions@minicircuits.com](mailto:testsolutions@minicircuits.com)

Included Accessories	Part Number	Description
	CBL-3W-xx	AC power cord (IEC C13 connector to local plug) Select one option from the list below. Please contact Please contact <a href="mailto:testsolutions@minicircuits.com">testsolutions@minicircuits.com</a> if your regions is not listed.
	USB-CBL-AB-7+	USB cable (6.8ft) type A to type B
	CBL-RJ45-MM-5+	Ethernet cable (5 ft)
	HT-4-SMA	SMA connector wrench (4" length)

AC Power Cord Options	Part Number	Description
	CBL-3W-US	USA NEMA 5-15 plug (type B) to IEC C13 connector
	CBL-3W-EU	Europe CEE 7/7 plug (type E/F) to IEC C13 connector
	CBL-3W-UK	UK BS-1363 plug (type G) to IEC C13 connector
	CBL-3W-AU	Australia & China AS/NZS 3112 plug (type I) to IEC C13 connector
	CBL-3W-IL	Israel SI-32 plug (type H) to IEC C13 connector

### NOTES

- Performance and quality attributes and conditions not expressly stated in this specification document are intended to be excluded and do not form a part of this specification document.
- Electrical specifications and performance data contained in this specification document are based on Mini-Circuit's applicable established test performance criteria and measurement instructions.
- The parts covered by this specification document are subject to Mini-Circuits standard limited warranty and terms and conditions (collectively, "Standard Terms"); Purchasers of this part are entitled to the rights and benefits contained therein. For a full statement of the standard terms and the exclusive rights and remedies thereunder, please visit Mini-Circuits' website at [www.minicircuits.com/terms/viewterm.html](http://www.minicircuits.com/terms/viewterm.html)





## Outline Dimensions

YT2786

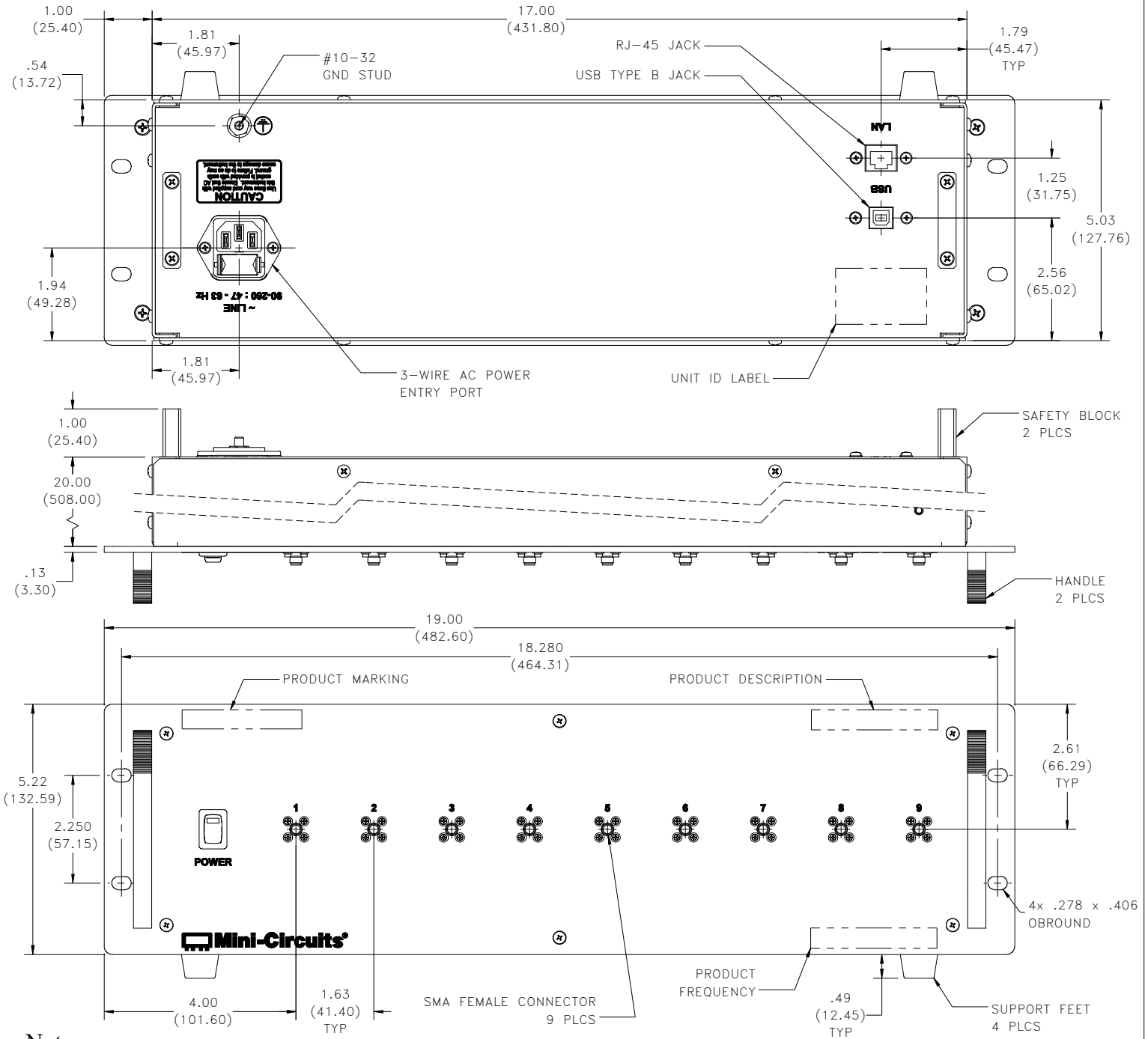

**Notes:**

1. Case material: Aluminum (with protective coating to prevent corrosion).
2. Dimensions are in inches (mm). Tolerances: 2 Pl.  $\pm .03$  inch; 3 Pl.  $\pm .015$  inch.
3. Weight: 13520 grams.
4. Marking may contain other features or characters for internal lot control.



P.O. Box 350166, Brooklyn, New York 11235-0003 (718) 934-4500 Fax (718) 332-4661 For detailed performance specs & shopping online see Mini-Circuits web site



The Design Engineers Search Engine Provides ACTUAL Data Instantly From MINI-CIRCUITS At: [www.minicircuits.com](http://www.minicircuits.com)

RF/IF MICROWAVE COMPONENTS



Environmental Specifications **ENV55**

All Mini-Circuits products are manufactured under exacting quality assurance and control standards, and are capable of meeting published specifications after being subjected to any or all of the following physical and environmental test.

Specification	Test/Inspection Condition	Reference/Spec
Operating Temperature	-0° to 50° C Ambient Environment	Individual Model Data Sheet
Storage Temperature	-20° to 60° C Ambient Environment	Individual Model Data Sheet
Operating and Storage Humidity	5% to 85% RH (non-condensing)	Ambient
Bench Handling Test	Bench Top Tip 45° & Drop	MIL-PRF-28800F
Transit Drop Test	Free Fall Drop, 20 cm (7.9 inches)	MIL-PRF-28800F Class 3