



## USB & ETHERNET & DAISY-CHAIN

# 8-Channel Attenuator

## ZT8DAT-8G95SF

50 Ω 1 to 8000 MHz 0 to 95 dB Rack-Mount SMA Female

### THE BIG DEAL

- 8 independently programmable channels
- 0-95 dB attenuation per channel in 0.25 dB steps
- 100 dB isolation between channels
- Configure automated sweep, hop & fading sequences
- Daisy-chain control stacking of multiple attenuator systems
- Convenient rack-mountable chassis
- SSH secure Ethernet communication



Generic photo used for illustration purposes only

### APPLICATIONS

- Benchtop and rack-mounted automated test systems
- 5G FR1, WiFi 6E MIMO, IoT & Zigbee device testing
- C-band radar & Satcom testing
- Transmission loss, signal fading & cellular handover testing

### FUNCTIONAL BLOCK DIAGRAM

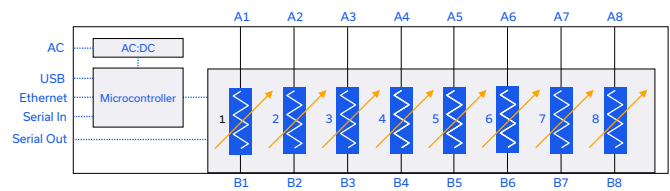

### PRODUCT OVERVIEW

Mini-Circuits' ZTDAT series multi-channel programmable attenuator systems are ideal for a wide range of signal level control applications including transmission loss simulation, signal fading, and MIMO measurements. ZT8DAT-8G95SF operates from 1 MHz to 8 GHz with typically 100 dB isolation between 8 bi-directional attenuator channels. Each channel can be independently controlled from 0 to 95 dB attenuation with 0.25 dB resolution.

The system is housed in a compact, 1U height, 19-inch rack chassis, with all SMA female connectors on the front panel and power and control connections out of the way on the rear panel.

The system can be controlled via USB or Ethernet (supporting SSH, HTTP & Telnet protocols). Full software support is provided, including our user-friendly GUI application for Windows, flexible API, and programming instructions for Windows and Linux environments.

The daisy-chain control interface with "dynamic addressing" simplifies control integration by interconnecting multiple attenuator racks via their respective serial in and out connections. The system automatically identifies and addresses all devices within the daisy chain, allowing each to be independently controlled through the single USB / Ethernet connection of the first unit in the chain.

### KEY FEATURES

Feature	Advantages
Sweep/hop / fading sequences	Configure a wide range of real-world scenarios in a test environment, including receiver sensitivity, device / base-station handovers, device failures, and interference effects.
High isolation	High isolation between channels and from input to output when max attenuation is set; minimizes cross-talk and measurement errors.
Rack-mount chassis	Compact 1U height, 19" rack-mountable chassis suits integration in automated production test environments
Secure Ethernet communication	Support for SSH (Secure Shell protocol) provides a means for secure communication over Ethernet networks with strict security policies. HTTP & Telnet communication via Ethernet are also supported.





## ELECTRICAL SPECIFICATIONS AT +25°C

Parameter	Conditions	Min.	Typ.	Max.	Units
Frequency Range		1		8000	MHz
Attenuation Range <sup>2</sup>	1 - 7200 MHz	0		95	dB
	7200 - 8000 MHz	0		90	
Attenuation Steps	1 - 7200 MHz		0.25		dB
	7200 - 8000 MHz		0.5		
Insertion Loss	1 - 2000 MHz		4.0	7.5	dB
	2000 - 4000 MHz		6.5	9.0	
	4000 - 6000 MHz		8.0	10.5	
	6000 - 8000 MHz		10.5	13.0	
Isolation	Ax to Bx @ max attenuation		100		dB
	Between channels (1 - 7200 MHz)		100		
	Between channels (7200 - 8000 MHz)		90		
Return Loss	1 - 8000 MHz		15		dB
Minimum Dwell Time <sup>3</sup>			600		μs
Attenuation Transition Time <sup>4</sup>			650		ns
Input Operating Power <sup>5</sup>	1 MHz			+17	dBm
	50 - 8000 MHz			+28	

1. Attenuator RF ports are interchangeable and support simultaneous, bidirectional signal transmission within the specified power limits

2. Relative to insertion loss

3. The time taken to respond to a command to change attenuation states (ignores USB / Ethernet communication time)

4. Time between starting to change the attenuation state and settling on the requested value

5. Derate linearly from +28dBm @ 50MHz to +17dBm @ 1MHz

## TYPICAL ATTENUATION ACCURACY AT +25°C

Frequency Range	Attenuation Range	Typ	Max	Units
1 - 2000 MHz	0.25 - 20 dB	±0.30	±(0.25+5% of nominal value)	dB
	20.25 - 60 dB	±1.40	±(0.4+4.5% of nominal value)	
	60.25 - 90 dB	±2.30	±(0.5+4% of nominal value)	
2000 - 4000 MHz	0.25 - 20 dB	±0.30	±(0.25+5.5% of nominal value)	dB
	20.25 - 60 dB	±0.85	±(0.35+4% of nominal value)	
	60.25 - 90 dB	±1.30	±(0.3+3.5% of nominal value)	
4000 - 6000 MHz	0.25 - 20 dB	±0.20	±(0.3+5.5% of nominal value)	dB
	20.25 - 60 dB	±0.50	±(0.8+3% of nominal value)	
	60.25 - 90 dB	±1.00	±(0.7+3.5% of nominal value)	
6000 - 8000 MHz	0.25 - 20 dB	±0.20	±(0.3+6% of nominal value)	dB
	20.25 - 60 dB	±1.20	±(0.6+4% of nominal value)	
	60.25 - 90 dB	±2.10	±(0.2+4.5% of nominal value)	



### TYPICAL PERFORMANCE CURVES

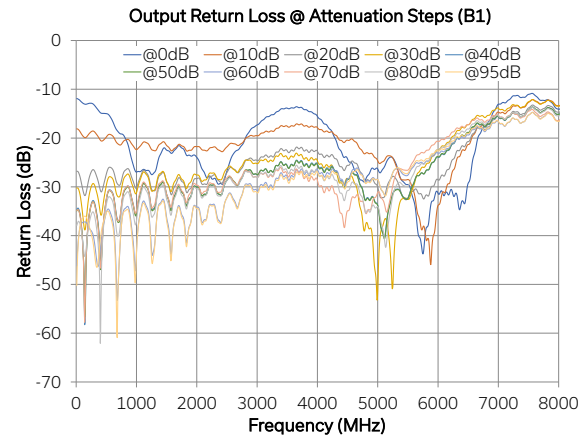
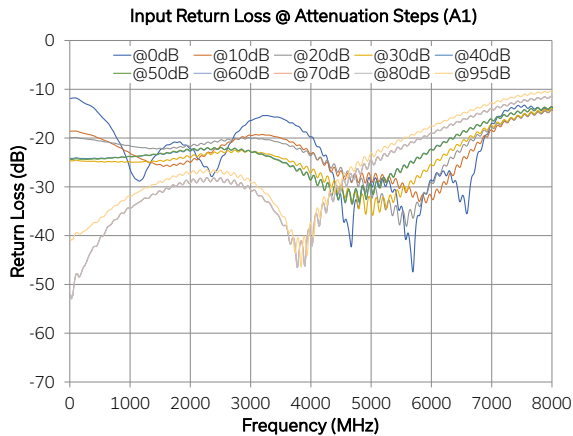
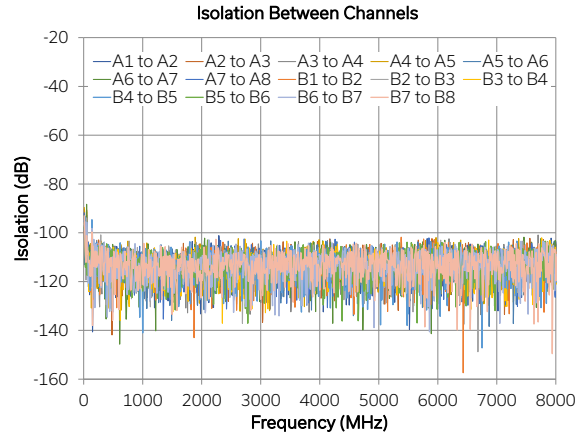
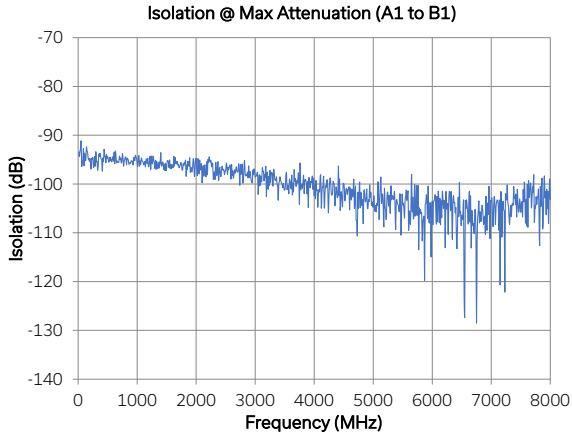
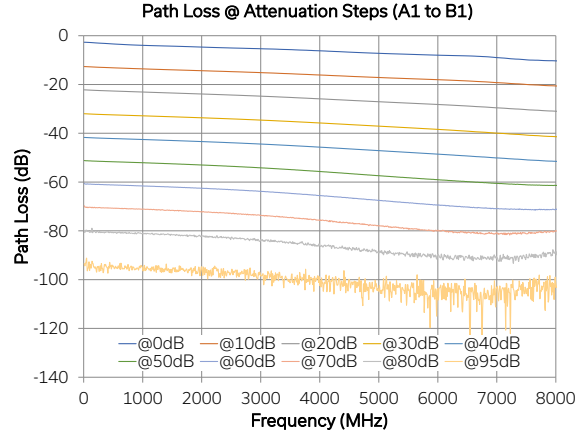
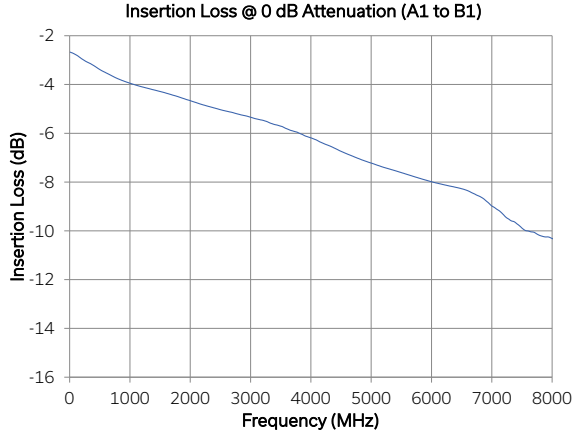

**CONTROL INTERFACES**

Ethernet Control	Supported Protocols	TCP / IP, SSH, HTTP, Telnet, DHCP, UDP (limited)
	Max Data Rate	100 Mbps (100Base-T Full Duplex)
USB Control	Supported Protocols	HID – High Speed
	Min Communication Time <sup>6</sup>	400 μs typ
Daisy-Chain	Supported Protocols	Mini-Circuits proprietary
	Requirements	Additional ZTDAT attenuator racks with one unit connected using USB or Ethernet

6. Based on the polling interval of the USB HID protocol (125 μs with 64 bytes per packet) and no other significant CPU or USB activity

**SOFTWARE & DOCUMENTATION**

Mini-Circuits' full software and support package including user guide, Windows GUI, API, programming manual and examples can be downloaded free of charge (refer to the last page for the download path).

A comprehensive set of software control options is provided:

- GUI for Windows – Simple software interface for control via Ethernet and USB
- Programming / automation via Ethernet
  - Complete set of control commands which can be sent via any supported protocol – simple to implement in the majority of modern programming environments
- Programming / automation via USB
  - DLL files provide a full API for Windows with a set of intuitive functions which can be implemented in any programming environment supporting .Net Framework or ActiveX
  - Direct USB programming is possible in any other environment (not supporting .Net or ActiveX)

Please contact [testsolutions@minicircuits.com](mailto:testsolutions@minicircuits.com) for support

**MINIMUM SYSTEM REQUIREMENTS**

Hardware	Intel i3 (or equivalent) or later
GUI (USB or Ethernet Control)	Windows 7 or later
USB API DLL	Windows 7 or later with support for Microsoft .Net Framework or ActiveX
USB Direct Programming	Windows 7 or later; Linux
Ethernet	Windows, Linux or macOS with Ethernet TCP / IP support

**PROGRAMMING COMMANDS**

The key ASCII / SCPI commands for control of the system for control via the Ethernet or USB API are summarized below (refer to the programming manual for full details):

Command / Query	Description
:MN?	Read model name
:SN?	Read serial number
:FIRMWARE?	Read firmware version
:CHAN:[channels]:SETATT:[value]	Set attenuation <ul style="list-style-type: none"> <li>• [channels] = Channel number to set (1 to 8) within the ZTDAT attenuator rack. Multiple channels can be listed in a string, separated by a colon (":").</li> <li>• [value] = Attenuator value in dB (from 0.00 to 95.00)</li> <li>• Example :CHAN:1:2:3:SETATT:10.25</li> </ul>
:[address]:[channel]:ATT?	Return a single attenuator value <ul style="list-style-type: none"> <li>• [channels] = Channel number to query (1 to 8) within the ZTDAT attenuator rack</li> <li>• Example :CHAN:1:ATT?</li> </ul>



### GRAPHICAL USER INTERFACE (GUI) FOR WINDOWS

- Connect via USB or Ethernet
- Run GUI in "demo mode" to evaluate software without a hardware connection

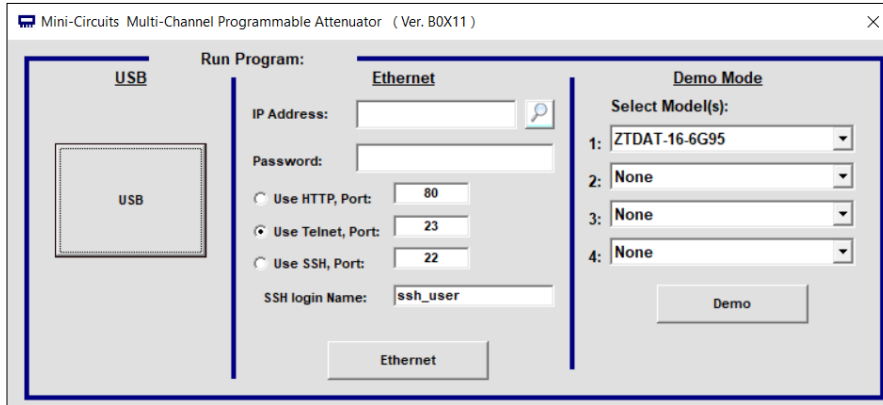

- View and set all attenuator values independently or in groups
- Configure automated sweep / hop / fading sequences
- Configure system and Ethernet settings

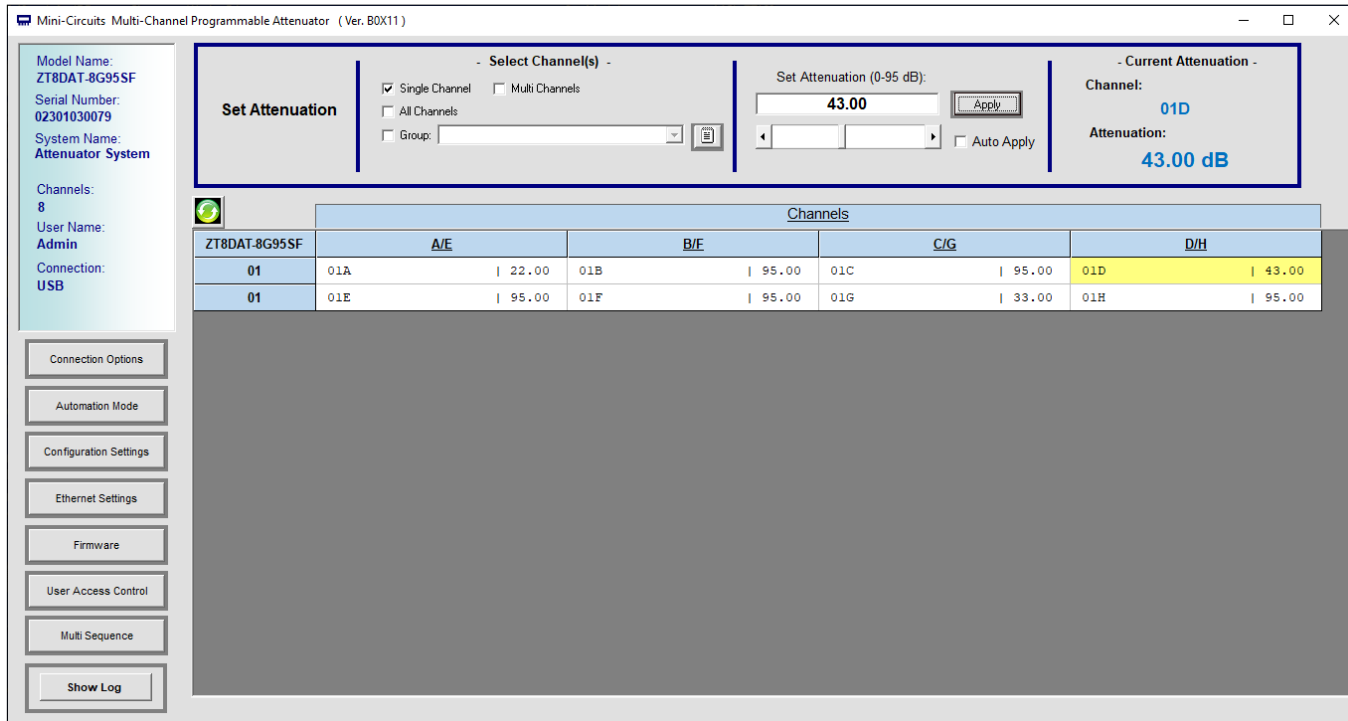



### ABSOLUTE MAXIMUM RATINGS<sup>7</sup>

Parameter	Conditions	Limits	Units
Temperature	Operating	0 to +50	°C
	Storage	-20 to +60	
Input Power (No Damage)	1 MHz	+17	dBm
	50 – 8000 MHz	+28	

7. Permanent damage may occur if any of these limits are exceeded. Operating in the range between operating power limits and absolute maximum ratings for extended periods may result in reduced life and reliability.

8. Derate linearly from +28dBm @ 50MHz to +17dBm @1MHz

### POWER SUPPLY

Power Supply	AC mains input: 100-240 V, 50 / 60 Hz
Fuse	2A, 250V rating
Power Consumption	85W maximum

### ELECTRICAL SCHEMATIC

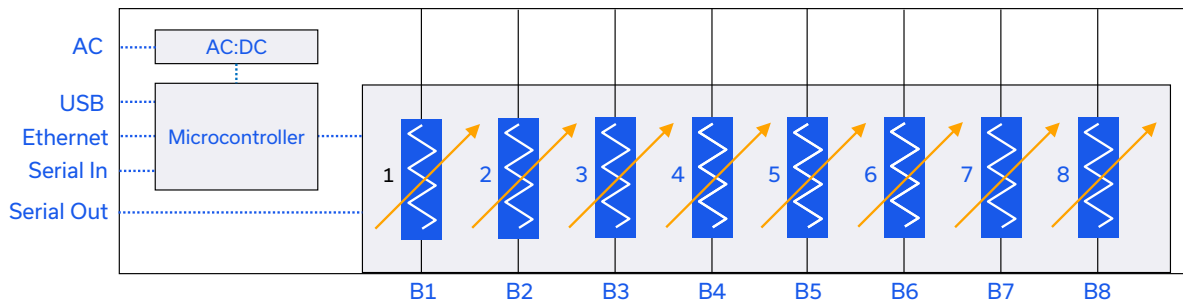

### CONNECTIONS

Port	Connector
A1-A8; B1-B8	SMA female
USB	USB type B
Ethernet / LAN	RJ45
Serial In & Serial Out	D-Sub 9-pin
AC Input	IEC C14 inlet



# 8-Channel Attenuator

## ZT8DAT-8G95SF

50 Ω 1 to 8000 MHz 0 to 95 dB Rack-Mount SMA Female

### CASE STYLE DRAWING

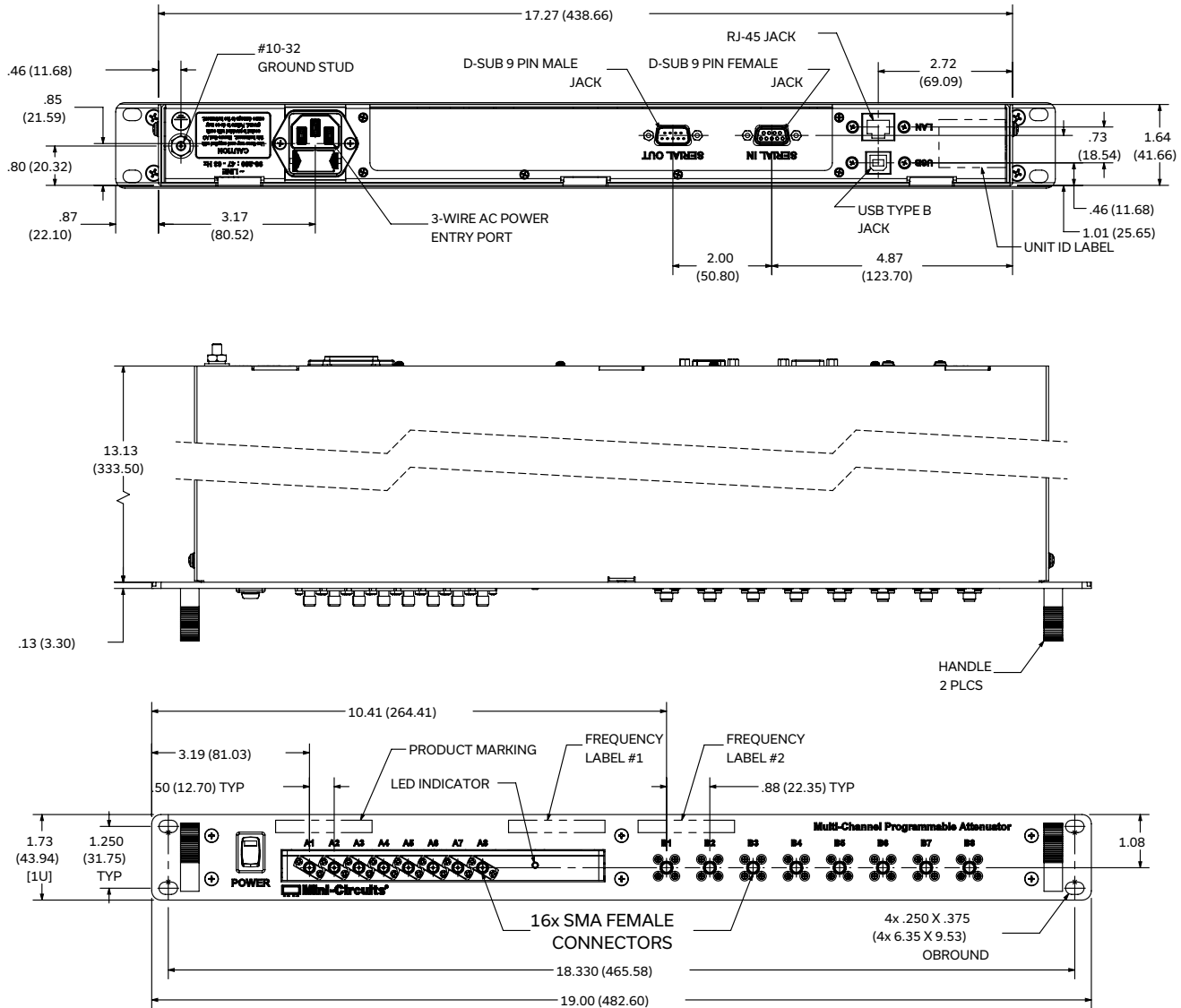

Weight: 3280 grams.  
Dimensions are in inches (mm). Tolerances: 2 Pl.±.03 inch; 3 Pl.±.015 inch.

### PRODUCT MARKING\*

Product Marking: ZT8DAT-8G95SF  
 Product Description: Multi-Channel Programmable Attenuator  
 Frequency Label #1: +28 dBm Max: >50 MHz  
 Frequency Label #2: +17 dBm Max: <50 MHz  
 Unit ID Label: Serial number and other identification marks

\*Marking may contain other features or characters for internal lot control



# 8-Channel Attenuator

**ZT8DAT-8G95SF**











50 Ω 1 to 8000 MHz 0 to 95 dB Rack-Mount SMA Female

DETAILED MODEL INFORMATION IS AVAILABLE ON OUR WEBSITE [CLICK HERE](#)

Case Style	AAD3575	
Software, User Guide & Programming Manual	<a href="http://www.minicircuits.com/softwaredownload/multiatt.html">www.minicircuits.com/softwaredownload/multiatt.html</a>	
Environmental Rating	ENV55	
Regulatory Compliance	<p>Refer to our website for compliance methodologies and qualifications</p> 	<a href="http://www.minicircuits.com/quality/environmental_introduction.html">www.minicircuits.com/quality/environmental_introduction.html</a>

Contact Us: [testsolutions@minicircuits.com](mailto:testsolutions@minicircuits.com)

Included Accessories	Part Number	Description
	CBL-3W-xx	AC power cord (IEC C13 connector to local plug) Select one option from the list below. Please contact Please contact <a href="mailto:testsolutions@minicircuits.com">testsolutions@minicircuits.com</a> if your regions is not listed.
	USB-CBL-AB-7+	USB cable (6.8ft) type A to type B
	CBL-RJ45-MM-5+	Ethernet cable (5 ft)
	D-SUB9-MF-6+	Serial daisy-chain control cable (6") with D-sub 9-pin connectors
	HT-4-SMA	SMA connector wrench (4" length)

AC Power Cord Options	Part Number	Description
	CBL-3W-US	USA NEMA 5-15 plug (type B) to IEC C13 connector
	CBL-3W-EU	Europe CEE 7/7 plug (type E/F) to IEC C13 connector
	CBL-3W-UK	UK BS-1363 plug (type G) to IEC C13 connector
	CBL-3W-AU	Australia & China AS/NZS 3112 plug (type I) to IEC C13 connector
	CBL-3W-IL	Israel SI-32 plug (type H) to IEC C13 connector

- NOTES**
- A. Performance and quality attributes and conditions not expressly stated in this specification document are intended to be excluded and do not form a part of this specification document.
  - B. Electrical specifications and performance data contained in this specification document are based on Mini-Circuit's applicable established test performance criteria and measurement instructions.
  - C. The parts covered by this specification document are subject to Mini-Circuits standard limited warranty and terms and conditions (collectively, "Standard Terms"); Purchasers of this part are entitled to the rights and benefits contained therein. For a full statement of the standard. Terms and the exclusive rights and remedies thereunder, please visit Mini-Circuits' website at [www.minicircuits.com/MCLStore/terms.jsp](http://www.minicircuits.com/MCLStore/terms.jsp)





## Outline Dimensions

AAD3575

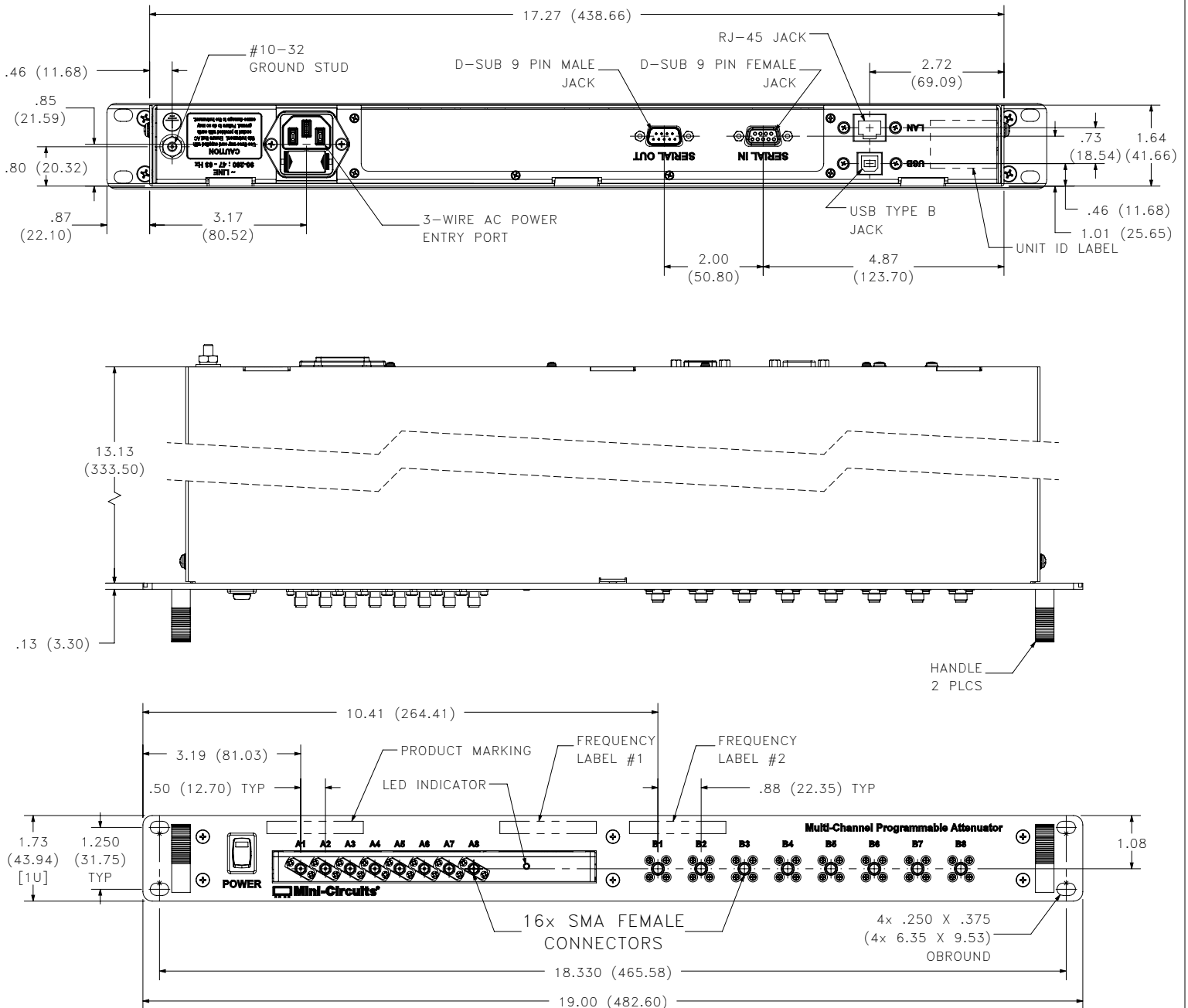

### Notes:

1. Case material: Aluminum (with protective coating to prevent corrosion).
2. Dimensions are in inches (mm). Tolerances: 2 Pl.  $\pm .03$  inch; 3 Pl.  $\pm .015$  inch.
3. Weight: 3280 grams.
4. Marking may contain other features or characters for internal lot control.



P.O. Box 350166, Brooklyn, New York 11235-0003 (718) 934-4500 Fax (718) 332-4661 For detailed performance specs & shopping online see Mini-Circuits web site



The Design Engineers Search Engine Provides ACTUAL Data Instantly From MINI-CIRCUITS At: [www.minicircuits.com](http://www.minicircuits.com)

RF/IF MICROWAVE COMPONENTS



Environmental Specifications **ENV55**

All Mini-Circuits products are manufactured under exacting quality assurance and control standards, and are capable of meeting published specifications after being subjected to any or all of the following physical and environmental test.

Specification	Test/Inspection Condition	Reference/Spec
Operating Temperature	-0° to 50° C Ambient Environment	Individual Model Data Sheet
Storage Temperature	-20° to 60° C Ambient Environment	Individual Model Data Sheet
Operating and Storage Humidity	5% to 85% RH (non-condensing)	Ambient
Bench Handling Test	Bench Top Tip 45° & Drop	MIL-PRF-28800F
Transit Drop Test	Free Fall Drop, 20 cm (7.9 inches)	MIL-PRF-28800F Class 3