



TTL

Mechanical Switch Assembly

ZT-375-TTL

Mini-Circuits

50Ω DC to 18 GHz SP4T + SPDT Rack-Mount SMA Female

THE BIG DEAL

- 5 x SP4T + 5 x SPDT mechanical absorptive switches
- TTL for simple control integration
- Convenient rack-mountable chassis
- Fail-safe / redundancy switching
- LED switch state indicators

APPLICATIONS

- Benchtop and rack-mounted automated test systems
- 5G FR1, WiFi 6E, UWB, Bluetooth
- Military radio, radar & electronic warfare
- Switch matrices

PRODUCT OVERVIEW

Mini-Circuits' ZT-375-TTL houses 5 x SPDT and 5 x SP4T absorptive electro-mechanical switches. Each switch operates over an extremely wide bandwidth, from DC to 18 GHz with high isolation and low insertion loss. The absorptive switches are failsafe, with a break-before-make configuration and extended switching lifetime.

The switches are housed in a rugged 19-inch, 3U rack chassis with the SMA (female) RF connectors, LED state indicators and 9-pin D-sub control input for each switch grouped together on the rear panel. Independent TTL control inputs for each switch support integration with a wide range of control systems capable of TTL logic levels, without the overhead of a PC. A single AC mains supply input provides power for the whole system, with an on / off power switch on the front panel.

KEY FEATURES

Feature	Advantages
Mechanical switches	Mechanical absorptive switches provide low loss, high isolation, high reliability, repeatable performance and internal termination of input signals on the disconnected paths
Fail-safe design	The switches revert to a known default state when the DC supply is removed, allowing their use in systems that must continue to operate safely in the event of power failure
TTL control	Simple control via TTL logic levels allows integration with a wide range of microcontroller, embedded or custom systems.
Rack-mount chassis	19" rack-mountable chassis suits integration in automated production test environments.



Front View



Rear View

Generic photo used for illustration purposes only

FUNCTIONAL BLOCK DIAGRAM (EACH SWITCH PAIR)

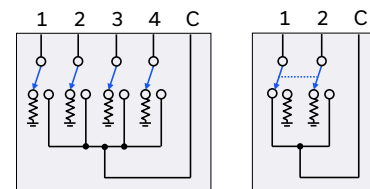



TTL

Mechanical Switch Assembly

ZT-375-TTL

Mini-Circuits

50Ω DC to 18 GHz SP4T + SPDT Rack-Mount SMA Female

ELECTRICAL SPECIFICATIONS AT +25°C (EACH SPDT SWITCH)

Parameter	Conditions	Min.	Typ.	Max.	Units
Frequency Range		DC		18	GHz
Insertion Loss	DC - 8 GHz		0.15	0.30	dB
	8 - 12 GHz		0.25	0.40	
	12 - 18 GHz		0.30	0.50	
Isolation (Inactive Paths) ¹	DC - 8 GHz	75	90		dB
	8 - 12 GHz	70	80		
	12 - 18 GHz	60	66		
Return Loss ²	DC - 8 GHz		20		dB
	8 - 12 GHz		20		
	12 - 18 GHz		19		
Switching Time			25		ms
RF Input Power (Cold Switching)	DC-18 GHz			20	W
	Into internal termination			1	
Switch Lifetime	100 mW hot switching ³		5		cycles million
	1W hot switching		1		

ELECTRICAL SPECIFICATIONS AT +25°C (EACH SP4T SWITCH)

Parameter	Conditions	Min.	Typ.	Max.	Units
Frequency Range		DC		18	GHz
Insertion Loss	DC - 8 GHz		0.15	0.30	dB
	8 - 12 GHz		0.25	0.40	
	12 - 18 GHz		0.50	0.80	
Isolation (Inactive Paths) ¹	DC - 8 GHz	80	100		dB
	8 - 12 GHz	75	95		
	12 - 18 GHz	60	80		
Return Loss ⁴	DC - 8 GHz		20		dB
	8 - 12 GHz		20		
	12 - 18 GHz		17		
Switching Time			25		ms
RF Input Power (Cold Switching) ⁵	DC-18 GHz			20	W
	Into internal termination			1	
Switch Lifetime	100 mW hot switching ³	10			cycles million
	1W hot switching		1		

1. Isolation measured between Com and any disconnected port. Example: Isolation for Com to 1 is the leakage measured at port 1 from a signal input at Com when the active switch path is set to Com to 2.

2. Return loss into all ports in all states

3. Hot switching power above this level will degrade the switch lifetime

4. Return loss into Com when active or ports 1-4 in any state; Com is reflective when disconnected

5. Maximum power into any internal termination is 1W per port, 3W total per switch





TTL

Mechanical Switch Assembly

ZT-375-TTL

Mini-Circuits

50Ω DC to 18 GHz SP4T + SPDT Rack-Mount SMA Female

CONNECTIONS

Port	Connector
SW1-5 (C & 1-4 each)	SMA female
SW 6-10 (C & 1-2 each)	SMA female
SW1-10 TTL	D-sub 9-pin
AC Input	IEC C14 inlet

D-SUB PIN-OUT

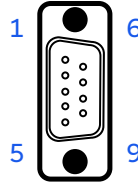

TTL CONTROL INTERFACE

TTL Level	Min	Typ	Max	Units
Low	0		0.7	V
High	3		5	

SWITCH CONTROL LOGIC TABLE (EACH SP4T SWITCH)

TTL Control Inputs									Switch x State	LED State			
Pin 1	Pin 2	Pin 3	Pin 4	Pin 5	Pin 6	Pin 7	Pin 8	Pin 9		LED1	LED2	LED3	LED4
GND	Low	Low	Low	Low	N/C	N/C	N/C	N/C	All ports disconnected ¹	Off	Off	Off	Off
GND	High	Low	Low	Low	N/C	N/C	N/C	N/C	C to 1	On	Off	Off	Off
GND	Low	High	Low	Low	N/C	N/C	N/C	N/C	C to 2	Off	On	Off	Off
GND	Low	Low	High	Low	N/C	N/C	N/C	N/C	C to 3	Off	Off	On	Off
GND	Low	Low	Low	High	N/C	N/C	N/C	N/C	C to 4	Off	Off	Off	On

1. Ports 1-4 internally terminated; Com port open (reflective)

SWITCH CONTROL LOGIC TABLE (EACH SPDT SWITCH)

TTL Control Inputs									Switch x State	LED State
Pin 1	Pin 2	Pin 3	Pin 4	Pin 5	Pin 6	Pin 7	Pin 8	Pin 9		
GND	Low	N/C	N/C	N/C	N/C	N/C	N/C	N/C	C to 1	Orange
GND	High	N/C	N/C	N/C	N/C	N/C	N/C	N/C	C to 2	Green



TTL

Mechanical Switch Assembly

ZT-375-TTL

Mini-Circuits

50Ω DC to 18 GHz SP4T + SPDT Rack-Mount SMA Female

ABSOLUTE MAXIMUM RATINGS

Parameter	Conditions	Limits	Units
Temperature	Operating	0 to +50	°C
	Storage	-20 to +60	
Input Power (No Damage)	Cold switching	20	W
	Hot switching	1	
	Into internal termination	1	

Permanent damage may occur if any of these limits are exceeded. Operating in the range between operating power limits and absolute maximum ratings for extended periods of time may result in reduced life and reliability.

POWER SUPPLY

Power Supply	AC mains input: 100-240 V, 50 / 60 Hz
Fuse	2A, 250V rating
Power Consumption	150W maximum

FUNCTIONAL BLOCK DIAGRAM

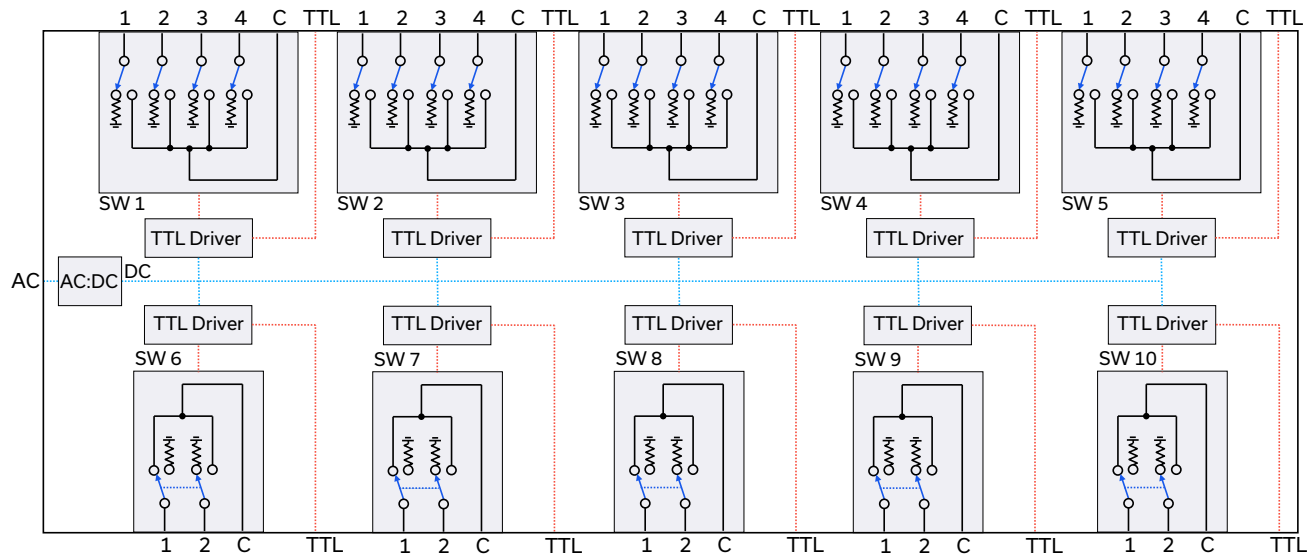



TTL

Mechanical Switch Assembly

ZT-375-TTL

Mini-Circuits

50Ω DC to 18 GHz SP4T + SPDT Rack-Mount SMA Female

TYPICAL PERFORMANCE DATA

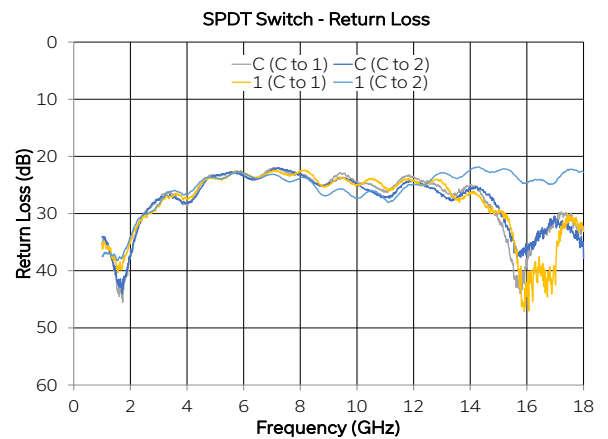
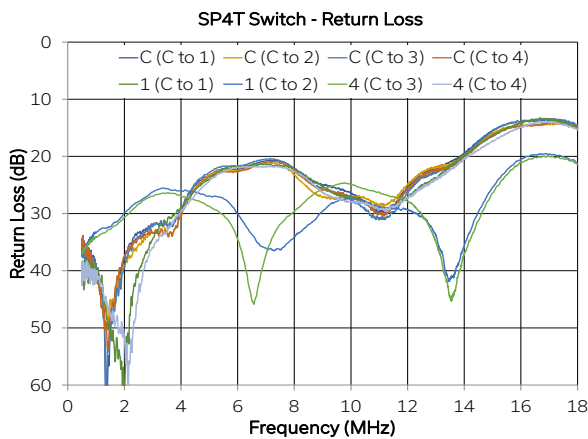
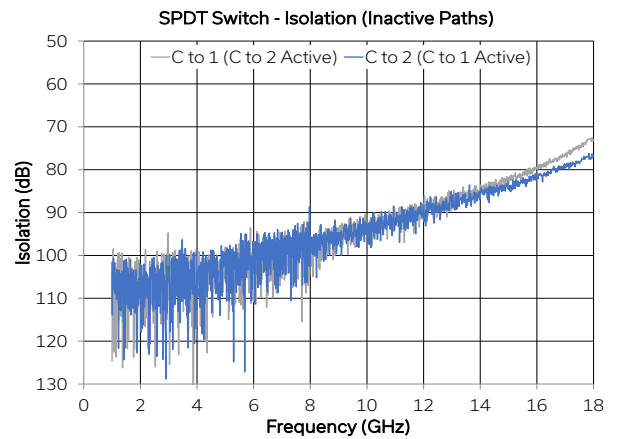
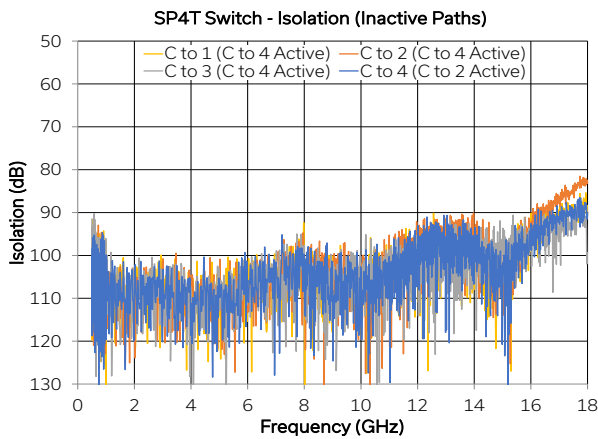
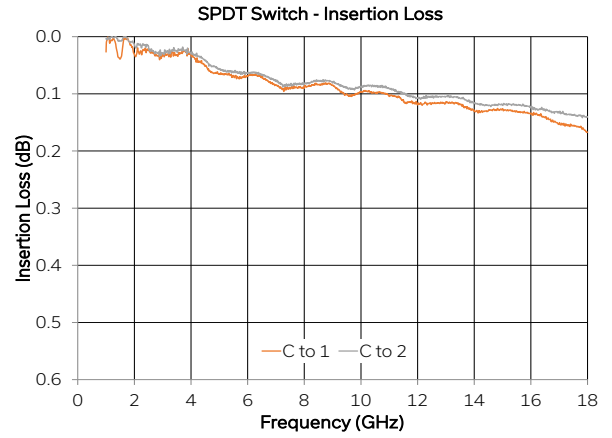
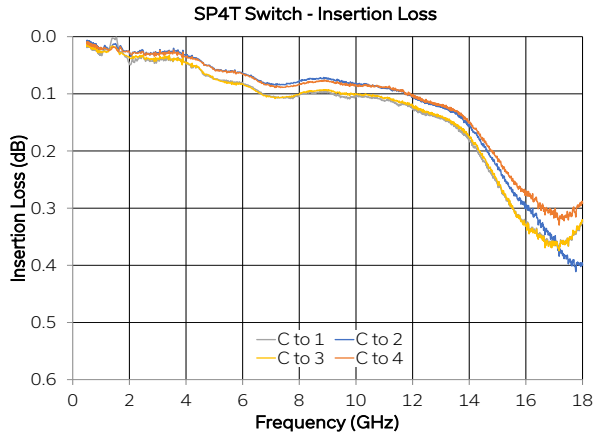



TTL

Mechanical Switch Assembly

ZT-375-TTL

50Ω DC to 18 GHz SP4T + SPDT Rack-Mount SMA Female

CASE STYLE DRAWING

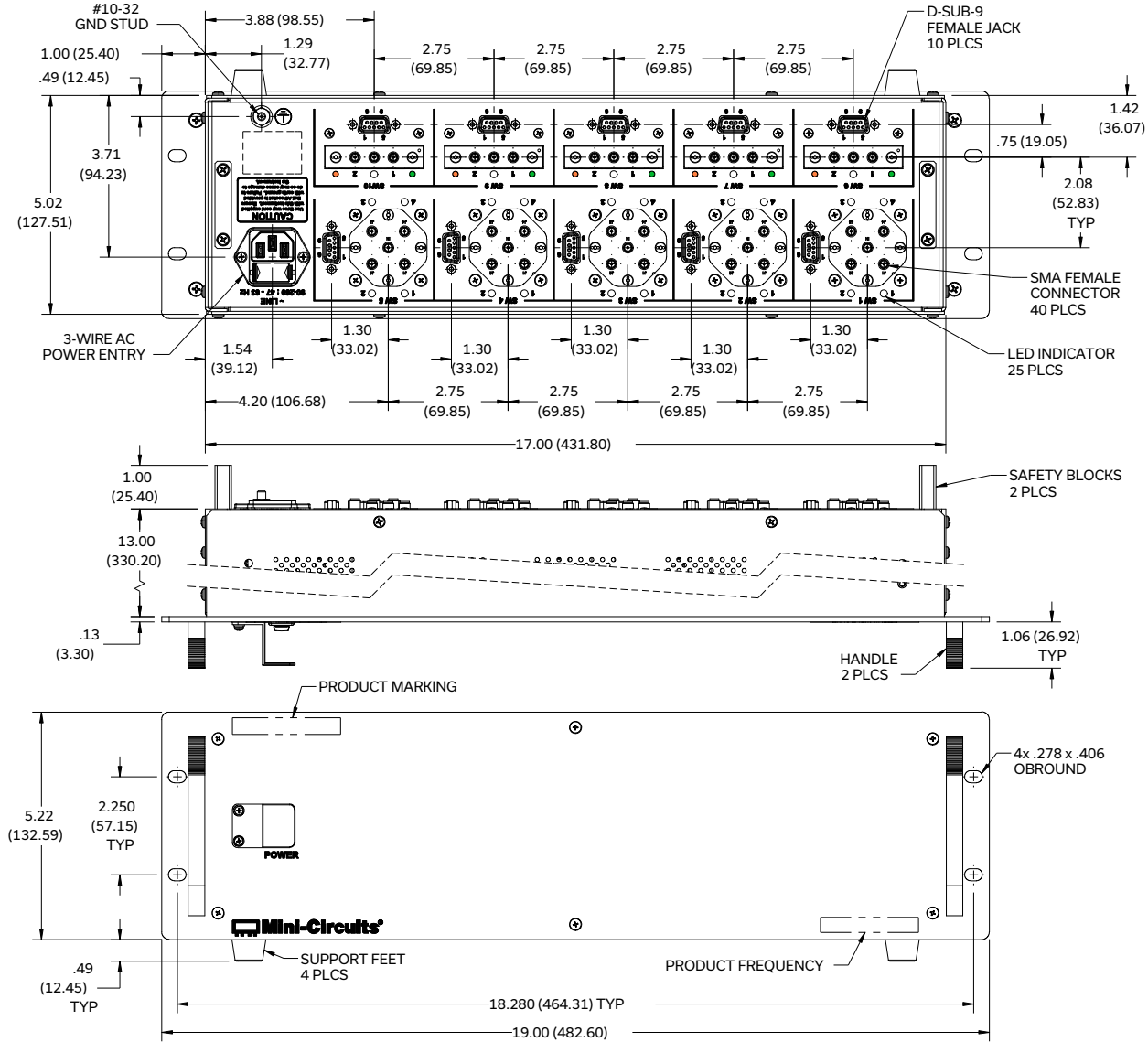

Weight: 5020 grams.

Dimensions are in inches (mm). Tolerances: 2 Pl. .03 inch; 3 Pl. .015 inch.

PRODUCT MARKING*

Product Marking: ZT-375-TTL

Product Frequency: DC-18 GHz

Unit ID Label: Serial number and other identification marks

*Marking may contain other features or characters for internal lot control





TTL

Mechanical Switch Assembly

ZT-375-TTL



Mini-Circuits





50Ω DC to 18 GHz SP4T + SPDT Rack-Mount SMA Female

DETAILED MODEL INFORMATION IS AVAILABLE ON OUR WEBSITE [CLICK HERE](#)

Case Style	NW3439	
Environmental Rating	ENV55	
Regulatory Compliance	<p>Refer to our website for compliance methodologies and qualifications</p> 	www.minicircuits.com/quality/environmental_introduction.html

Contact Us: testsolutions@minicircuits.com

Included Accessories	Part Number	Description
	CBL-3W-xx	AC power cord (IEC C13 connector to local plug) Select one option from the list below. Please contact testsolutions@minicircuits.com if your region is not listed.
	10 x D-SUB9-MPT-3	10 x TTL control cables; D-sub 9-pin connector to pig-tail; 3ft length
	HT-4-SMA	SMA connector wrench (4" length)

AC Power Cord Options	Part Number	Description
	CBL-3W-US	USA NEMA 5-15 plug (type B) to IEC C13 connector
	CBL-3W-EU	Europe CEE 7/7 plug (type E/F) to IEC C13 connector
	CBL-3W-UK	UK BS-1363 plug (type G) to IEC C13 connector
	CBL-3W-AU	Australia & China AS/NZS 3112 plug (type I) to IEC C13 connector
	CBL-3W-IL	Israel SI-32 plug (type H) to IEC C13 connector

- NOTES**
- A. Performance and quality attributes and conditions not expressly stated in this specification document are intended to be excluded and do not form a part of this specification document.
 - B. Electrical specifications and performance data contained in this specification document are based on Mini-Circuit's applicable established test performance criteria and measurement instructions.
 - C. The parts covered by this specification document are subject to Mini-Circuits standard limited warranty and terms and conditions (collectively, "Standard Terms"); Purchasers of this part are entitled to the rights and benefits contained therein. For a full statement of the standard. Terms and the exclusive rights and remedies thereunder, please visit Mini-Circuits' website at www.minicircuits.com/MCLStore/terms.jsp



Outline Dimensions

NW3439

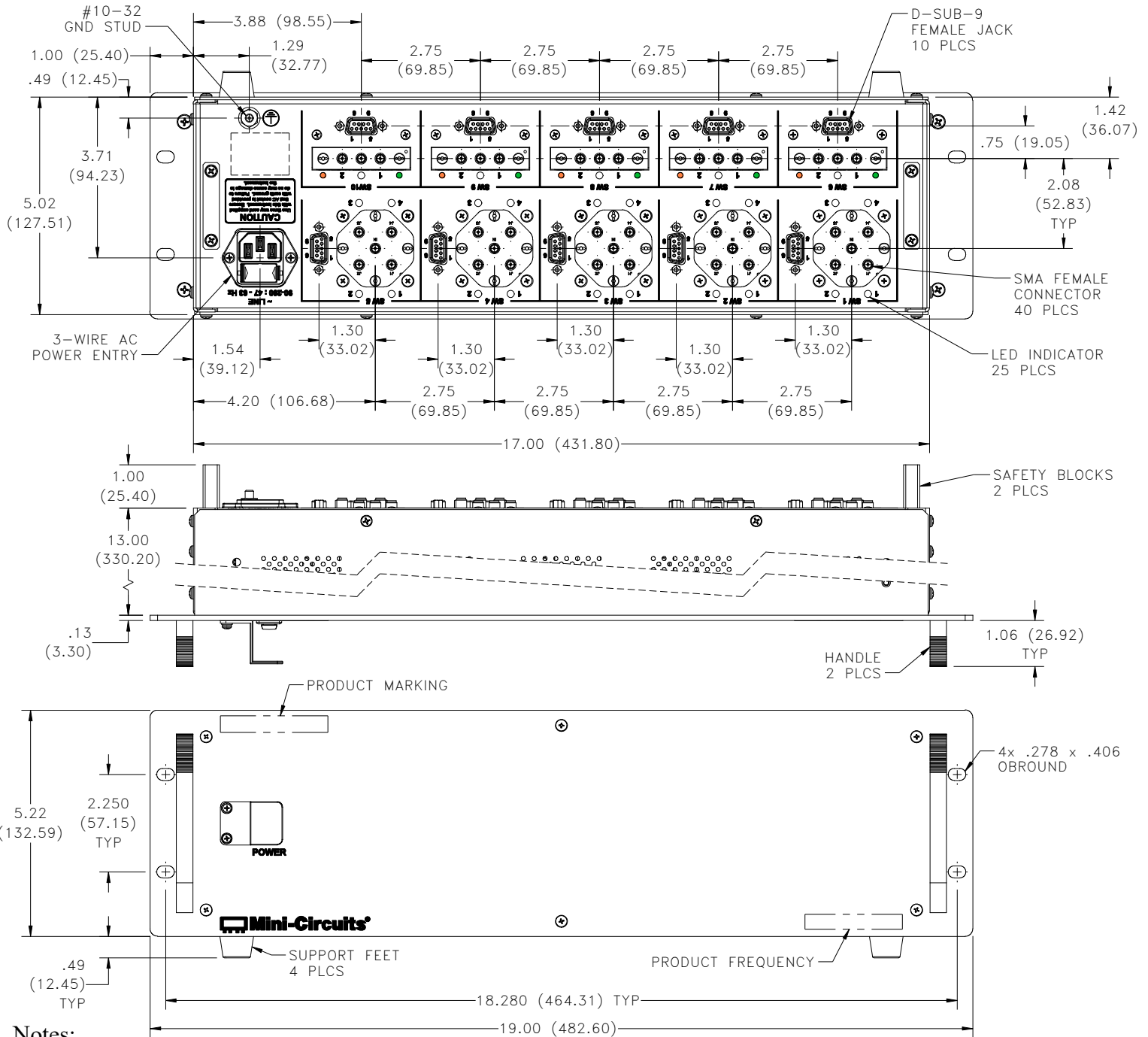

Notes:

1. Case material: Aluminum (with protective coating to prevent corrosion).
2. Dimensions are in inches (mm). Tolerances: 2 Pl. $\pm .03$ inch; 3 Pl. $\pm .015$ inch.
3. Weight: 5020 grams.
4. Marking may contain other features or characters for internal lot control.



P.O. Box 350166, Brooklyn, New York 11235-0003 (718) 934-4500 Fax (718) 332-4661 For detailed performance specs & shopping online see Mini-Circuits web site



The Design Engineers Search Engine Provides ACTUAL Data Instantly From MINI-CIRCUITS At: www.minicircuits.com

RF/IF MICROWAVE COMPONENTS



Environmental Specifications **ENV55**

All Mini-Circuits products are manufactured under exacting quality assurance and control standards, and are capable of meeting published specifications after being subjected to any or all of the following physical and environmental test.

Specification	Test/Inspection Condition	Reference/Spec
Operating Temperature	-0° to 50° C Ambient Environment	Individual Model Data Sheet
Storage Temperature	-20° to 60° C Ambient Environment	Individual Model Data Sheet
Operating and Storage Humidity	5% to 85% RH (non-condensing)	Ambient
Bench Handling Test	Bench Top Tip 45° & Drop	MIL-PRF-28800F
Transit Drop Test	Free Fall Drop, 20 cm (7.9 inches)	MIL-PRF-28800F Class 3