

High Power, Solid state

SPDT RF Switch

ZSW2-272VHDR+

50 Ω Reflective RF switch 30 to 2700 MHz
Internal driver, Single Supply Voltage 2.3V to 3.6V

The Big Deal

- High power 20W
- Low loss, 0.35 up to 1 GHz
- High linearity, IP3 +85 dBm @850 MHz

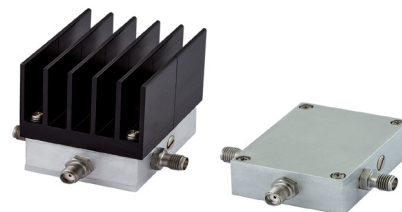

Model No.	ZSW2-272VHDR+	ZSW2-272VHDRX+ Δ
With Bracket	ZSW2-272VHDRB+	ZSW2-272VHDRXB+ Δ
Case Style	QV2427	
Connectors	SMA	

Δ For ZSW2-272VHDRX+ heat sink not included. Alternative heat sinking and heat removal must be provided by the user to limit maximum base-plate temperature to 85°C, in order to ensure proper performance.

Applications

- Lab
- Instrumentation
- Automatic Test equipment (ATE)
- Base station
- Defense

+RoHS Compliant

The +Suffix identifies RoHS Compliance. See our web site for RoHS Compliance methodologies and qualifications

Product Overview

Mini-Circuits' ZSW2-272VHDR+ is a 50 Ω high power SPDT RF switch covering a broad frequency range from 30 to 2700 MHz with low insertion loss, and very high linearity.

The ZSW2-272VHDR+ operates on a single supply voltage from +2.3 V to +3.6 V with single pin control. The ZSW2-272VHDR+ comes in a rugged package and is available both with heatsink (2.025" x 1.63" x 1.89") and without heatsink (2.0" x 1.5" x 0.6").

Key Features

Feature	Advantages
Wideband, 30 to 2700 MHz	One model can be used in many applications, saving component count. Also ideal for wideband applications such as military and instrumentation.
High power: <ul style="list-style-type: none">• 20W up to 2000 MHz• 16W up to 2700 MHz	Suitable for signal routing applications with high power requirement such as antenna feeds in transmit systems and more.
Low insertion loss: <ul style="list-style-type: none">• 0.35 dB up to 1000 MHz• 0.50 dB up to 2000 MHz	Provides excellent transmission of signal power from input to output and minimizes overall system loss
High linearity, +85 dBm IP3	High linearity minimizes unwanted inter-modulation products which are difficult or impossible to filter in multi-carrier environments, or in the presence of strong interfering signals from adjacent circuitry received by the antenna.

RF Electrical Specifications: 30-2700 MHz, T_{AMB}=25°C, V_{DD}=+3.3V (unless noted otherwise)

Parameter	Port	Frequency	Min.	Typ.	Max.	Units
Operating Frequency	—	—	30	—	2700	MHz
Insertion Loss	—	30-1000 MHz	—	0.35	0.6	dB
		1000-2000 MHz		0.5	0.8	
		2000-2700 MHz		0.7	1.1	
Isolation	between RF COM and inactive ports	30-1000 MHz 1000-2000 MHz 2000-2700 MHz	32 25 21	40 30 24	—	dB
	between RF1 and RF2 ports	30-1000 MHz 1000-2000 MHz 2000-2700 MHz	34 27 23	42 33 28	—	dB
VSWR	RF COM port	30-1000 MHz 1000-2000 MHz 2000-2700 MHz	—	1.15 1.25 1.35	—	:1
	RF1/RF2 active port	30-1000 MHz 1000-2000 MHz 2000-2700 MHz	—	1.15 1.25 1.35	—	:1
Harmonics @ +15 dBm input power	—	30 - 2700 MHz	—	-95	—	dBc
Non Harmonic Spurs	—	—	—	-124	—	dBm
Input 0.1dB Compression ¹	RF COM to any active port	30-2000 MHz 2000-2700 MHz	—	+45.5 +44.5	—	dBm
IP3 ²	RF COM to any active port	850 MHz 2700 MHz	—	85 81	—	dBm
RF Input Power @ -40°C to +85°C, case temperature	CW (cold switching) ³	30-2000 MHz 2000-2700 MHz	—	—	43 42	dBm
	Pulsed ^{3,4}	30-2000 MHz 2000-2700 MHz	—	—	44.5 43.5	dBm
	Hot switching	30-2700 MHz	—	—	30	dBm
	Unbiased	30-2700 MHz	—	—	27	dBm

1. 0.1 dB compression is a measure of linearity. Do not exceed max power ratings (see absolute maximum ratings on next page).

2. IP3 was tested with +39 dBm per tone.

3. Max Power derates at temperatures over +65°C according to derating graph on page 3.

4. Refers to peak power, pulse signal used: 10% duty cycle, 4620 μs period.

DC Electrical Specifications

Parameter	Min.	Typ.	Max.	Units
V _{DD} , Supply Voltage	2.3	—	3.6	V
Supply Current ⁵	—	0.15	0.5	mA
Control Voltage Low	0	—	0.2xV _{DD} (max 0.6V)	V
Control Voltage High	0.8xV _{DD}	—	5.5	V
Control Current (per pin)	—	15	—	μA

5. Supply current may reach 3mA at startup.

Switching Specifications

Parameter	Conditions	Min.	Typ.	Max.	Units
Switching time 50% trigger to 10/90% signal level	Pulse rate =12.5[kHz], RF freq. =501[MHz]	—	15	25	μs
Video feedthrough @ all ports	V _{ctrl} =0/3V, Duty Cycle= 50%; Freq=12.5 kHz	—	1	—	mVpp
Switching frequency	—	—	—	12.5	kHz

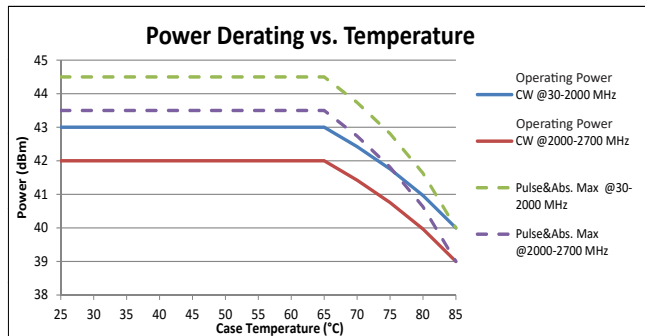

Absolute Maximum Ratings ^{6,7}

Parameter	Ratings
Operating Temperature, case ⁸	-40°C to +85°C
Storage Temperature	-55°C to +100°C
V _{DD} , Supply Voltage	-5V Min. 3.6V Max.
Control Voltage	-0.3V Min. 5.5V Max.
ESD, HBM	Class 1C (Pass 1000V)
RF input power @ -40°C to +65°C, case ⁸	44.5dBm @ 30-2000MHz 43.5dBm @ 2000-2700MHz
RF input power @ +65°C to +85°C, case ⁸	See derating curves
DC voltage on RF pins @ RF In ≤ 0 dBm	15V

The RF switch control bit selects the desired switch-state, as shown in **Table 1: Truth Table**.

Table 1: Truth Table.

STATE	Control Input	RF Input / Output	
	Control V1	RF COM to RF1	RF COM to RF2
1	Low	OFF	ON
2	High	ON	OFF

Note : V1 is connected to internal pull-up resistor.

6. Operation of this device above any of these conditions may cause permanent damage.
7. Operation in the range between the max operating power and the absolute maximum rating for extended periods of time may result in reduced life and reliability.
8. Case temperature is defined as the temperature at the base plate - the heat sink mounting surface.

Simplified Diagram

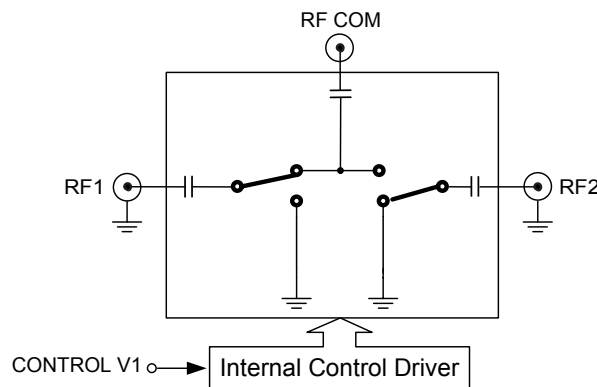

Connections

RF1	(SMA female)
RF2	(SMA female)
RF COM	(SMA female)
DC Supply and Control	9 Pin D-Sub female*

*9 Pin D-Sub Pin Connections

PIN Number	Function
3	Not Connected
4	V _{control}
5	V _{DD}
1-2,6-9	GND ⁹

9. Only one of the GND pins is required to be connected for proper operation.

Outline Drawing (QV2427)

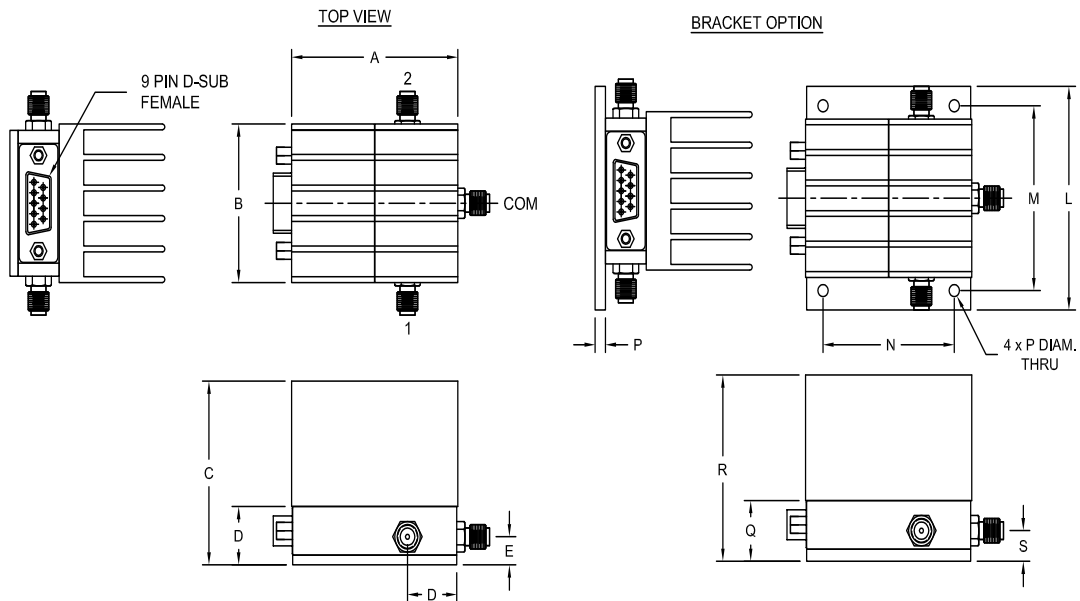

Mounting information for models without heatsink.

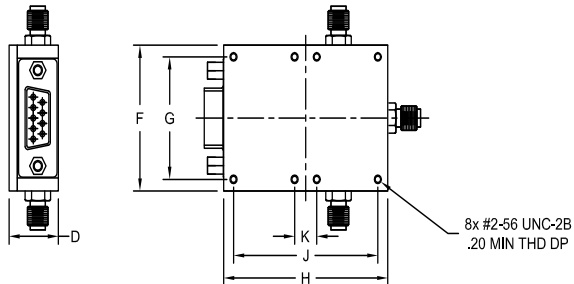

Outline Dimensions (inch / mm)

A	B	C	D	E	F	G	H	J	K	L	M	N	P	Q	R	S	WT. GRAMS
2.025	1.63	1.89	.600	.29	1.500	1.260	2.000	1.760	0.270	2.30	1.900	1.600	.125	.625	1.915	.315	150
51.44	41.4	48.0	15.24	7.37	38.10	32.0	50.80	44.7	6.86	58.4	48.3	40.6	3.18	15.9	48.64	8.0	

Typical Performance Curves

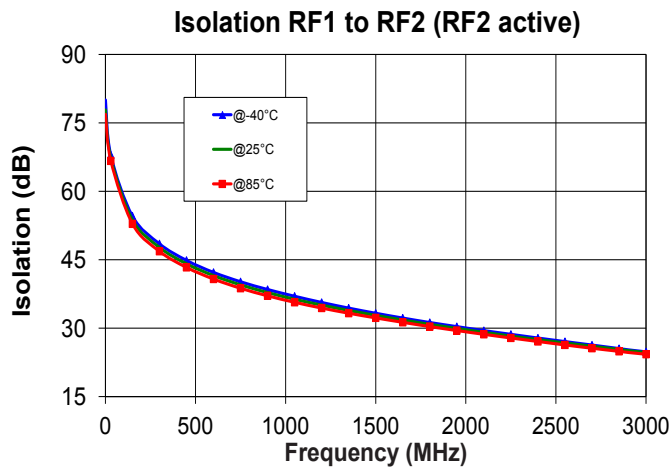
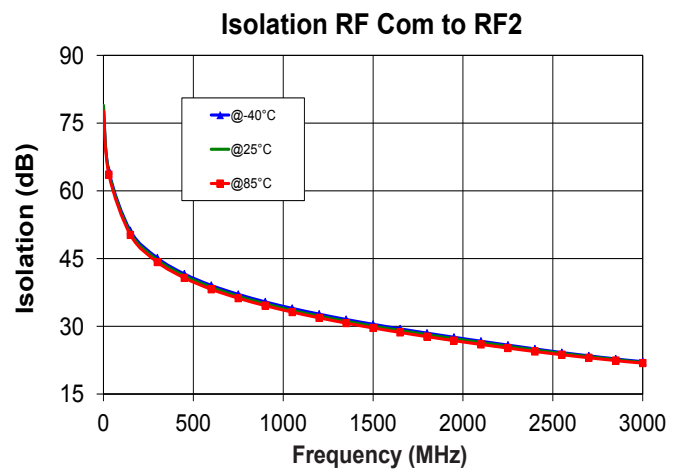
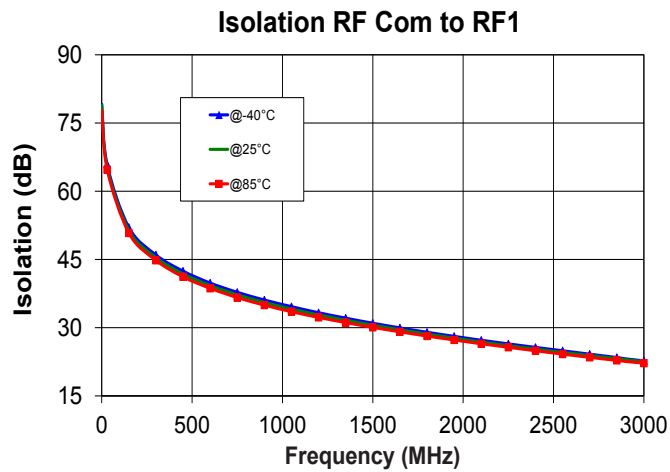
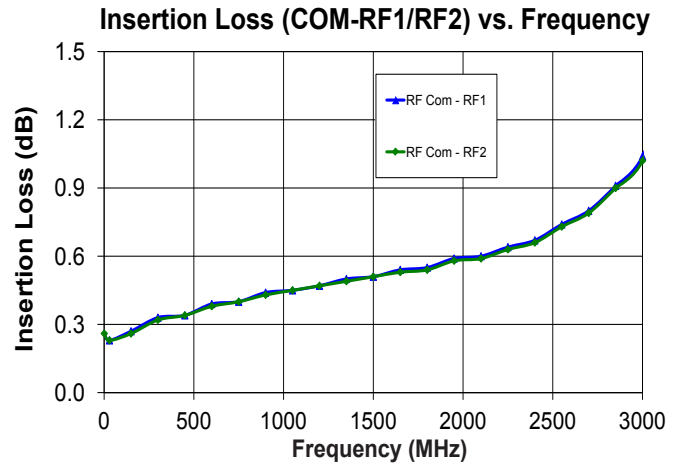
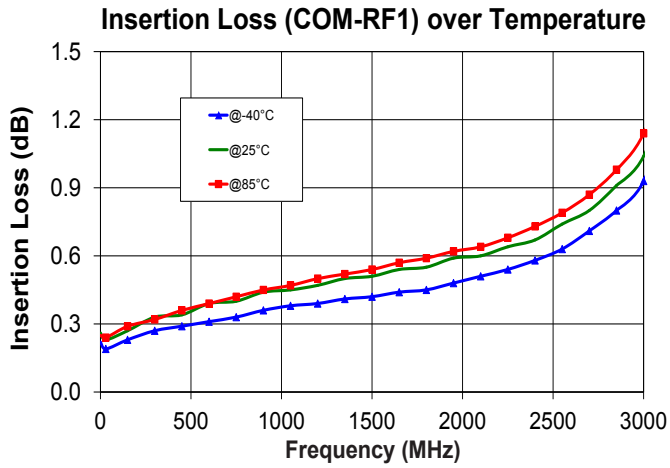

Typical Performance Curves (Continued)

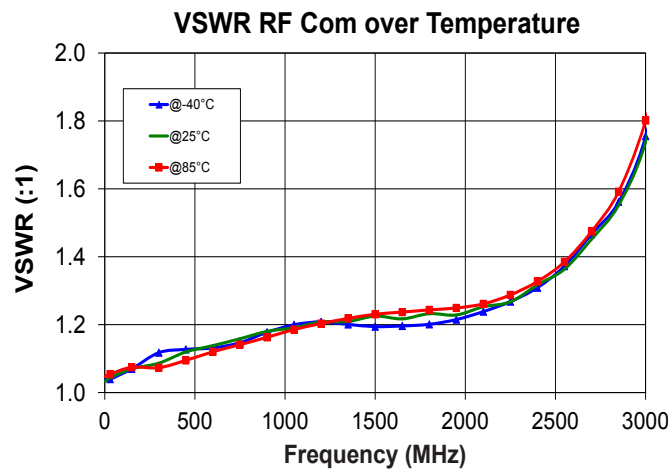
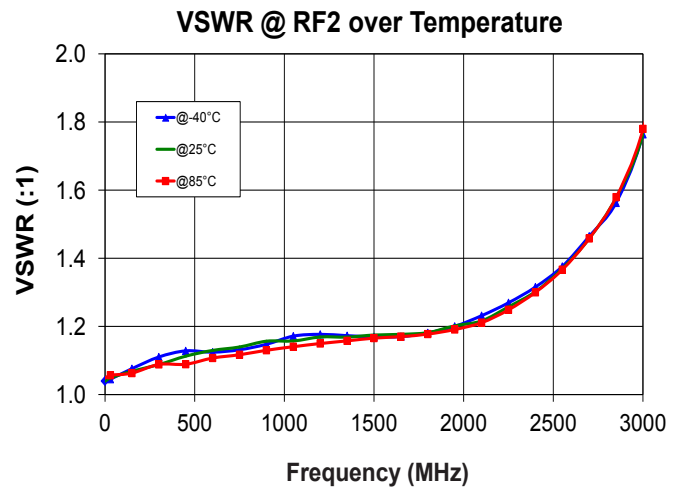
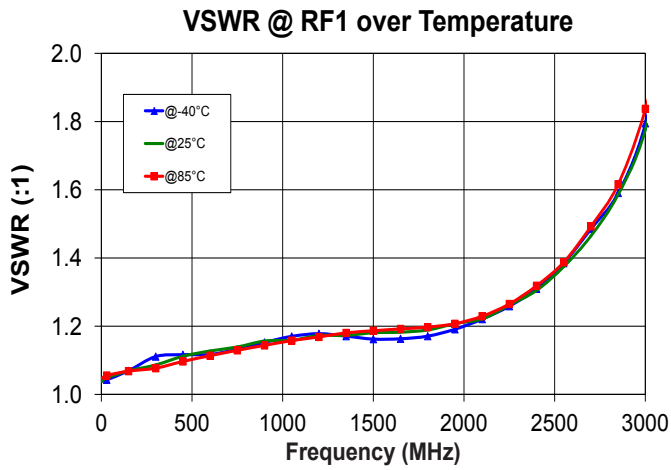

Additional Notes

- A. Performance and quality attributes and conditions not expressly stated in this specification document are intended to be excluded and do not form a part of this specification document.
- B. Electrical specifications and performance data contained in this specification document are based on Mini-Circuit's applicable established test performance criteria and measurement instructions.
- C. The parts covered by this specification document are subject to Mini-Circuits standard limited warranty and terms and conditions (collectively, "Standard Terms"); Purchasers of this part are entitled to the rights and benefits contained therein. For a full statement of the Standard Terms and the exclusive rights and remedies thereunder, please visit Mini-Circuits' website at www.minicircuits.com/MCLStore/terms.jsp

RF SPDT Switch

ZSW2-272VHDR+

Typical Performance Data

TEST CONDITIONS: @Temperature = -40degC Power In = 0dBm

FREQUENCY (MHz)	INSERTION LOSS		ISOLATION			VSWR		
	(dB)		(dB)			(:1)		
	COM-J1	COM-J2	COM-J1	COM-J2	J1-J2	COM	J1	J2
1	0.22	0.19	79.11	78.50	80.04	1.04	1.04	1.04
10	0.19	0.19	74.17	72.52	75.49	1.04	1.04	1.04
20	0.19	0.20	69.18	67.84	71.41	1.04	1.04	1.04
30	0.19	0.20	65.94	64.53	68.01	1.04	1.04	1.05
40	0.20	0.20	63.50	62.19	65.83	1.04	1.04	1.05
50	0.20	0.20	61.60	60.47	63.88	1.04	1.04	1.05
60	0.20	0.21	60.05	58.96	62.38	1.04	1.04	1.05
70	0.21	0.21	58.69	57.67	61.12	1.04	1.04	1.05
80	0.21	0.21	57.53	56.53	59.94	1.04	1.05	1.05
90	0.22	0.22	56.52	55.55	58.94	1.04	1.05	1.05
100	0.22	0.22	55.61	54.62	58.04	1.05	1.05	1.06
200	0.25	0.25	49.52	48.70	52.07	1.09	1.09	1.10
300	0.27	0.27	46.00	45.16	48.50	1.12	1.11	1.11
400	0.28	0.28	43.47	42.64	45.94	1.12	1.11	1.12
500	0.30	0.30	41.48	40.68	43.91	1.13	1.12	1.13
600	0.31	0.31	39.82	39.07	42.23	1.13	1.12	1.12
700	0.32	0.32	38.42	37.71	40.81	1.14	1.12	1.13
800	0.34	0.34	37.19	36.51	39.60	1.16	1.14	1.14
900	0.36	0.35	36.09	35.42	38.48	1.18	1.15	1.15
1000	0.37	0.37	35.10	34.44	37.49	1.19	1.16	1.16
1100	0.38	0.38	34.16	33.54	36.54	1.20	1.18	1.18
1200	0.39	0.39	33.29	32.70	35.64	1.21	1.18	1.18
1300	0.40	0.40	32.49	31.90	34.80	1.20	1.17	1.17
1400	0.41	0.41	31.72	31.15	34.01	1.20	1.17	1.17
1500	0.42	0.42	30.98	30.45	33.27	1.19	1.16	1.17
1600	0.43	0.42	30.29	29.77	32.56	1.19	1.16	1.17
1700	0.44	0.44	29.63	29.12	31.88	1.19	1.16	1.17
1800	0.45	0.45	28.99	28.49	31.24	1.20	1.17	1.18
1900	0.47	0.46	28.39	27.87	30.63	1.21	1.18	1.19
2000	0.49	0.48	27.80	27.28	30.04	1.22	1.20	1.21
2100	0.51	0.50	27.24	26.70	29.47	1.24	1.22	1.23
2200	0.53	0.52	26.70	26.12	28.92	1.26	1.24	1.26
2300	0.55	0.54	26.17	25.56	28.38	1.28	1.27	1.29
2400	0.58	0.56	25.67	25.00	27.84	1.31	1.31	1.32
2500	0.62	0.59	25.18	24.45	27.31	1.35	1.36	1.35
2600	0.66	0.63	24.68	23.94	26.80	1.41	1.42	1.40
2700	0.71	0.68	24.18	23.46	26.30	1.47	1.49	1.46
2800	0.77	0.74	23.69	23.01	25.79	1.53	1.56	1.53
2900	0.84	0.80	23.19	22.58	25.28	1.61	1.64	1.60
3000	0.93	0.90	22.70	22.17	24.81	1.76	1.80	1.76
3100	1.05	1.01	22.28	21.77	24.34	1.89	1.93	1.90
3200	1.19	1.15	21.87	21.42	23.91	2.05	2.10	2.07
3300	1.37	1.33	21.52	21.08	23.52	2.25	2.32	2.29
3400	1.58	1.52	21.23	20.74	23.17	2.48	2.57	2.49
3500	1.82	1.75	20.93	20.46	22.84	2.74	2.87	2.75
3600	2.09	2.00	20.67	20.24	22.52	3.03	3.18	3.04
3700	2.38	2.29	20.43	20.05	22.21	3.34	3.52	3.37
3800	2.69	2.61	20.19	19.93	21.94	3.70	3.90	3.76
4000	3.39	3.35	19.90	19.75	21.50	4.57	4.80	4.73

Notes

- A. Performance and quality attributes and conditions not expressly stated in this specification document are intended to be excluded and do not form a part of this specification document.
- B. Electrical specifications and performance data contained in this specification document are based on Mini-Circuits applicable established test performance criteria and measurement instructions.
- C. The parts covered by this specification document are subject to Mini-Circuits standard limited warranty and terms and conditions (collectively, "Standard Terms"); Purchasers of this part are entitled to the rights and benefits contained therein. For a full statement of the Standard Terms and the exclusive rights and remedies thereunder, please visit Mini-Circuits' website at www.minicircuits.com/MCLStore/terms.jsp



RF SPDT Switch

ZSW2-272VHDR+

Typical Performance Data

TEST CONDITIONS: @Temperature = +25degC Power In = 0dBm

FREQUENCY (MHz)	INSERTION LOSS		ISOLATION			VSWR		
	(dB)		(dB)			(:1)		
	COM-J1	COM-J2	COM-J1	COM-J2	J1-J2	COM	J1	J2
1	0.26	0.26	78.89	78.94	77.83	1.03	1.04	1.04
10	0.23	0.24	73.48	72.74	75.59	1.03	1.04	1.04
20	0.23	0.23	68.53	67.23	70.51	1.04	1.04	1.04
30	0.23	0.23	65.39	64.20	67.30	1.04	1.05	1.05
40	0.23	0.23	62.98	61.73	65.06	1.05	1.05	1.05
50	0.23	0.23	61.02	59.96	63.20	1.05	1.05	1.05
60	0.24	0.23	59.36	58.43	61.65	1.05	1.05	1.05
70	0.25	0.24	58.03	57.19	60.34	1.05	1.05	1.05
80	0.26	0.25	56.95	56.07	59.13	1.05	1.06	1.05
90	0.27	0.26	55.94	55.09	58.17	1.05	1.05	1.05
100	0.27	0.27	54.99	54.22	57.21	1.05	1.06	1.05
200	0.30	0.30	48.99	48.26	51.26	1.07	1.07	1.07
300	0.33	0.32	45.43	44.74	47.71	1.09	1.09	1.09
400	0.35	0.35	42.89	42.24	45.18	1.10	1.10	1.10
500	0.37	0.36	40.90	40.29	43.18	1.12	1.12	1.12
600	0.39	0.38	39.27	38.68	41.53	1.14	1.13	1.13
700	0.40	0.40	37.87	37.31	40.12	1.15	1.14	1.14
800	0.42	0.42	36.65	36.09	38.91	1.17	1.15	1.15
900	0.44	0.43	35.56	35.01	37.81	1.18	1.16	1.16
1000	0.45	0.44	34.56	34.02	36.81	1.19	1.16	1.16
1100	0.46	0.46	33.65	33.13	35.90	1.20	1.17	1.17
1200	0.47	0.47	32.81	32.28	35.06	1.21	1.17	1.17
1300	0.49	0.48	32.02	31.50	34.26	1.21	1.18	1.17
1400	0.50	0.49	31.27	30.77	33.52	1.22	1.18	1.17
1500	0.51	0.51	30.55	30.07	32.81	1.23	1.18	1.17
1600	0.52	0.52	29.87	29.40	32.12	1.23	1.18	1.18
1700	0.53	0.53	29.23	28.77	31.47	1.23	1.18	1.18
1800	0.55	0.54	28.60	28.15	30.84	1.23	1.19	1.18
1900	0.56	0.55	27.99	27.56	30.23	1.24	1.20	1.19
2000	0.58	0.57	27.42	26.97	29.65	1.24	1.21	1.20
2100	0.60	0.59	26.86	26.40	29.09	1.25	1.22	1.22
2200	0.62	0.61	26.32	25.85	28.55	1.27	1.24	1.24
2300	0.64	0.63	25.79	25.30	28.02	1.29	1.27	1.27
2400	0.67	0.66	25.30	24.77	27.50	1.32	1.30	1.30
2500	0.71	0.70	24.81	24.26	27.01	1.35	1.35	1.34
2600	0.75	0.74	24.34	23.76	26.52	1.40	1.40	1.40
2700	0.80	0.79	23.88	23.29	26.05	1.45	1.46	1.46
2800	0.87	0.86	23.43	22.84	25.58	1.52	1.54	1.53
2900	0.95	0.93	22.99	22.42	25.11	1.61	1.64	1.63
3000	1.04	1.02	22.56	22.01	24.66	1.74	1.78	1.76
3100	1.16	1.14	22.15	21.64	24.23	1.87	1.91	1.89
3200	1.30	1.28	21.77	21.30	23.81	2.02	2.07	2.05
3300	1.48	1.45	21.43	20.99	23.43	2.20	2.26	2.24
3400	1.67	1.64	21.12	20.71	23.08	2.41	2.49	2.46
3500	1.90	1.86	20.86	20.46	22.78	2.65	2.75	2.72
3600	2.17	2.13	20.64	20.24	22.50	2.94	3.04	3.01
3700	2.47	2.42	20.46	20.06	22.26	3.26	3.38	3.34
3800	2.80	2.75	20.32	19.92	22.07	3.63	3.76	3.73
4000	3.53	3.48	20.17	19.72	21.77	4.50	4.66	4.66

Notes

- A. Performance and quality attributes and conditions not expressly stated in this specification document are intended to be excluded and do not form a part of this specification document.
- B. Electrical specifications and performance data contained in this specification document are based on Mini-Circuits applicable established test performance criteria and measurement instructions.
- C. The parts covered by this specification document are subject to Mini-Circuits standard limited warranty and terms and conditions (collectively, "Standard Terms"); Purchasers of this part are entitled to the rights and benefits contained therein. For a full statement of the Standard Terms and the exclusive rights and remedies thereunder, please visit Mini-Circuits' website at www.minicircuits.com/MCLStore/terms.jsp



RF SPDT Switch

ZSW2-272VHDR+

Typical Performance Data

TEST CONDITIONS: @Temperature = +85degC Power In = 0dBm

FREQUENCY (MHz)	INSERTION LOSS		ISOLATION			VSWR		
	(dB)		(dB)			(:1)		
	COM-J1	COM-J2	COM-J1	COM-J2	J1-J2	COM	J1	J2
1	0.25	0.23	77.78	77.70	76.89	1.05	1.05	1.05
10	0.23	0.24	72.38	71.65	74.63	1.05	1.05	1.05
20	0.24	0.24	67.91	66.87	69.73	1.05	1.05	1.06
30	0.24	0.25	64.74	63.60	66.67	1.05	1.06	1.06
40	0.24	0.25	62.19	61.28	64.15	1.06	1.06	1.06
50	0.25	0.25	60.31	59.45	62.24	1.06	1.06	1.06
60	0.25	0.26	58.77	57.98	60.77	1.06	1.06	1.06
70	0.26	0.26	57.39	56.69	59.50	1.06	1.06	1.06
80	0.26	0.27	56.28	55.59	58.29	1.07	1.07	1.06
90	0.26	0.27	55.28	54.58	57.31	1.07	1.07	1.06
100	0.27	0.27	54.35	53.72	56.40	1.07	1.07	1.06
200	0.30	0.30	48.34	47.72	50.39	1.07	1.07	1.07
300	0.32	0.33	44.82	44.23	46.86	1.07	1.08	1.09
400	0.35	0.36	42.25	41.76	44.36	1.09	1.09	1.09
500	0.37	0.38	40.28	39.81	42.39	1.10	1.10	1.09
600	0.39	0.40	38.67	38.21	40.78	1.12	1.11	1.11
700	0.41	0.42	37.27	36.86	39.39	1.13	1.12	1.12
800	0.43	0.44	36.06	35.65	38.19	1.15	1.13	1.12
900	0.45	0.45	34.97	34.59	37.10	1.16	1.14	1.13
1000	0.47	0.47	33.99	33.62	36.14	1.18	1.15	1.14
1100	0.48	0.49	33.09	32.73	35.24	1.19	1.16	1.14
1200	0.50	0.50	32.27	31.89	34.42	1.20	1.17	1.15
1300	0.51	0.52	31.50	31.11	33.66	1.21	1.18	1.16
1400	0.53	0.53	30.77	30.36	32.94	1.22	1.18	1.16
1500	0.54	0.55	30.08	29.65	32.26	1.23	1.19	1.17
1600	0.56	0.56	29.42	28.98	31.60	1.24	1.19	1.17
1700	0.57	0.58	28.79	28.34	30.97	1.24	1.19	1.17
1800	0.59	0.59	28.17	27.72	30.36	1.24	1.20	1.18
1900	0.60	0.61	27.59	27.13	29.77	1.25	1.20	1.19
2000	0.62	0.63	27.02	26.55	29.21	1.25	1.21	1.20
2100	0.64	0.65	26.48	26.00	28.66	1.26	1.23	1.21
2200	0.67	0.67	25.95	25.46	28.12	1.28	1.25	1.23
2300	0.69	0.70	25.43	24.94	27.60	1.30	1.28	1.26
2400	0.73	0.73	24.94	24.43	27.09	1.33	1.32	1.30
2500	0.77	0.77	24.45	23.95	26.58	1.37	1.37	1.34
2600	0.81	0.82	23.97	23.48	26.09	1.42	1.42	1.39
2700	0.87	0.87	23.49	23.05	25.61	1.47	1.49	1.46
2800	0.94	0.95	23.04	22.63	25.16	1.55	1.58	1.54
2900	1.03	1.03	22.61	22.23	24.71	1.64	1.67	1.62
3000	1.14	1.14	22.20	21.87	24.29	1.80	1.84	1.78
3100	1.27	1.26	21.82	21.52	23.89	1.93	1.97	1.91
3200	1.42	1.41	21.47	21.21	23.51	2.08	2.14	2.07
3300	1.59	1.58	21.15	20.92	23.15	2.25	2.33	2.26
3400	1.78	1.79	20.86	20.66	22.83	2.45	2.54	2.47
3500	2.01	2.03	20.61	20.45	22.54	2.68	2.78	2.73
3600	2.27	2.32	20.41	20.27	22.29	2.94	3.06	3.04
3700	2.56	2.64	20.24	20.14	22.08	3.24	3.38	3.38
3800	2.86	2.98	20.11	20.03	21.91	3.57	3.71	3.76
4000	3.55	3.72	19.97	19.88	21.67	4.37	4.53	4.67

Notes

- A. Performance and quality attributes and conditions not expressly stated in this specification document are intended to be excluded and do not form a part of this specification document.
- B. Electrical specifications and performance data contained in this specification document are based on Mini-Circuits applicable established test performance criteria and measurement instructions.
- C. The parts covered by this specification document are subject to Mini-Circuits standard limited warranty and terms and conditions (collectively, "Standard Terms"); Purchasers of this part are entitled to the rights and benefits contained therein. For a full statement of the Standard Terms and the exclusive rights and remedies thereunder, please visit Mini-Circuits' website at www.minicircuits.com/MCLStore/terms.jsp



RF SPDT Switch

ZSW2-272VHDR+

Typical Performance Curves

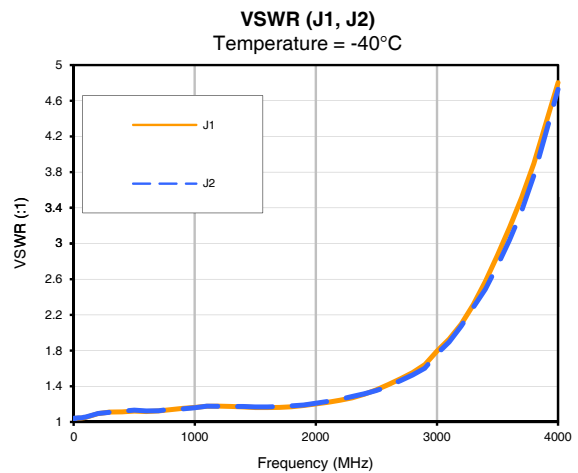
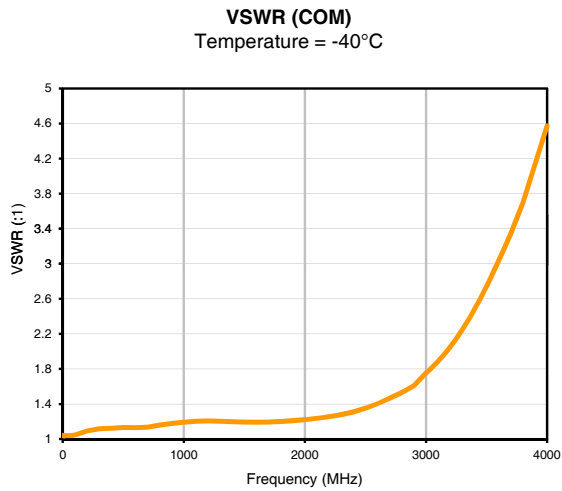
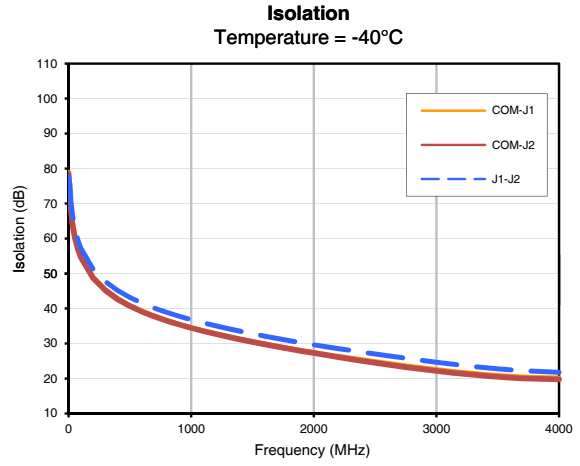
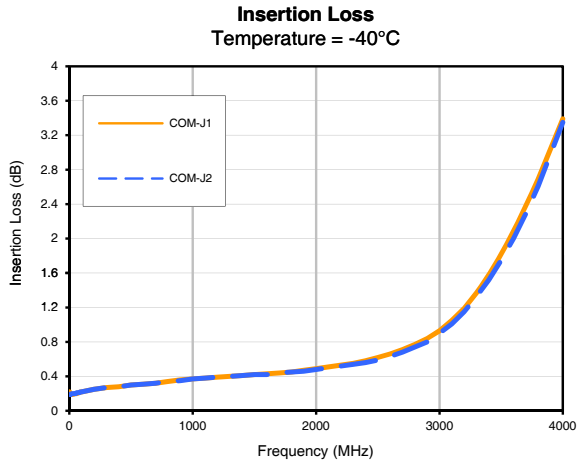

Notes

- A. Performance and quality attributes and conditions not expressly stated in this specification document are intended to be excluded and do not form a part of this specification document.
- B. Electrical specifications and performance data contained in this specification document are based on Mini-Circuits' applicable established test performance criteria and measurement instructions.
- C. The parts covered by this specification document are subject to Mini-Circuits' standard limited warranty and terms and conditions (collectively, "Standard Terms"); Purchasers of this part are entitled to the rights and benefits contained therein. For a full statement of the Standard Terms and the exclusive rights and remedies thereunder, please visit Mini-Circuits' website at www.minicircuits.com/MCStore/terms.jsp

RF SPDT Switch

ZSW2-272VHDR+

Typical Performance Curves

Insertion Loss
Temperature = +25°C

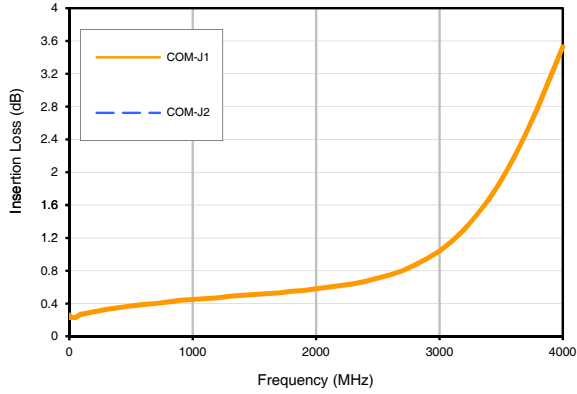

Isolation
Temperature = +25°C

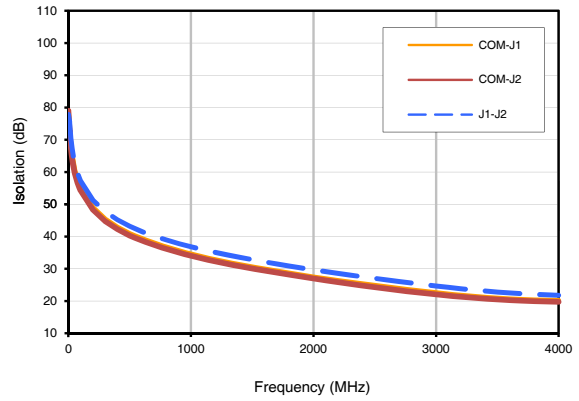

VSWR (COM)
Temperature = +25°C

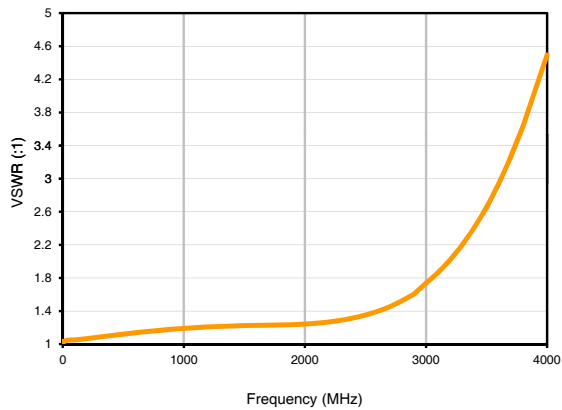

VSWR (J1, J2)
Temperature = +25°C

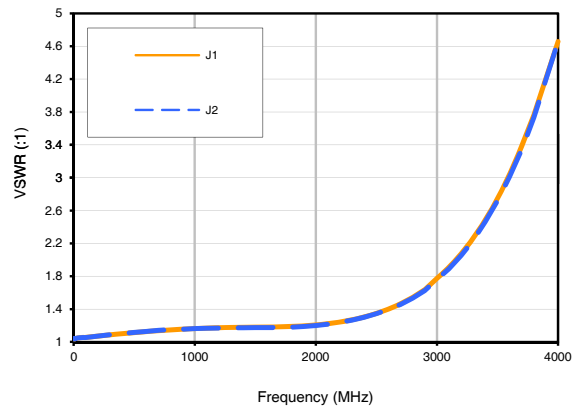

Notes

- A. Performance and quality attributes and conditions not expressly stated in this specification document are intended to be excluded and do not form a part of this specification document.
- B. Electrical specifications and performance data contained in this specification document are based on Mini-Circuits' applicable established test performance criteria and measurement instructions.
- C. The parts covered by this specification document are subject to Mini-Circuits' standard limited warranty and terms and conditions (collectively, "Standard Terms"); Purchasers of this part are entitled to the rights and benefits contained therein. For a full statement of the Standard Terms and the exclusive rights and remedies thereunder, please visit Mini-Circuits' website at www.minicircuits.com/MCLStore/terms.jsp

RF SPDT Switch

ZSW2-272VHDR+

Typical Performance Curves

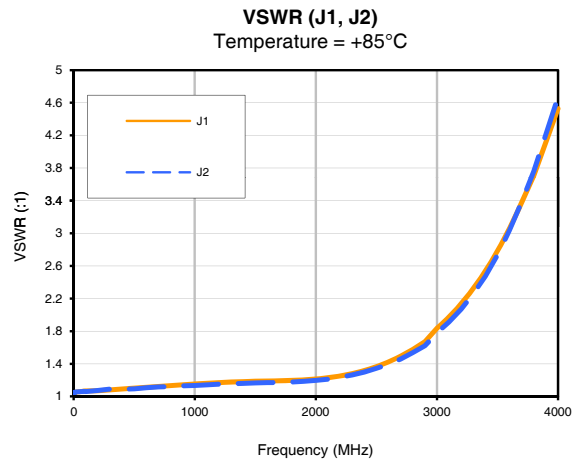
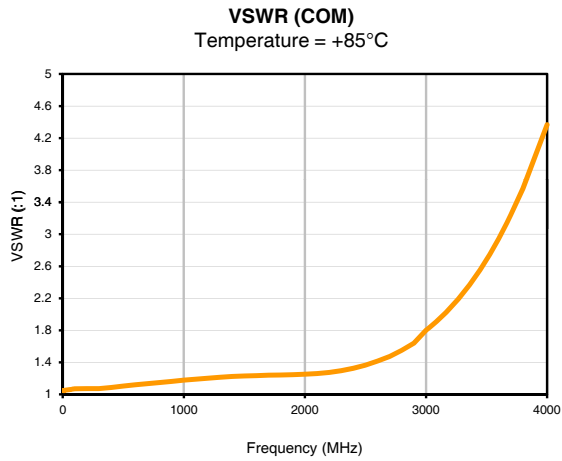
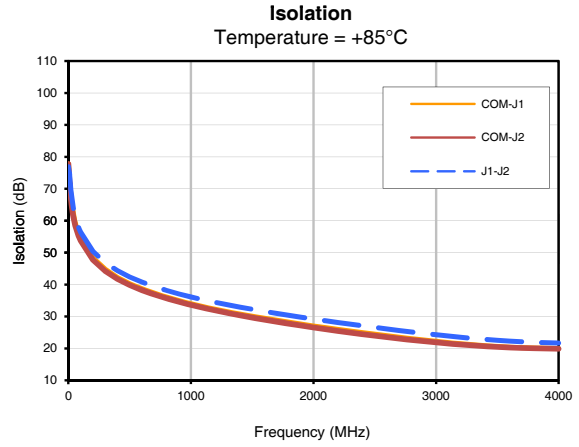
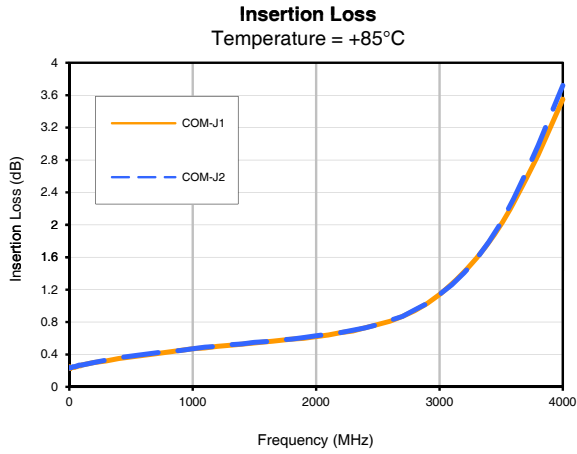

Notes

- A. Performance and quality attributes and conditions not expressly stated in this specification document are intended to be excluded and do not form a part of this specification document.
- B. Electrical specifications and performance data contained in this specification document are based on Mini-Circuits' applicable established test performance criteria and measurement instructions.
- C. The parts covered by this specification document are subject to Mini-Circuits' standard limited warranty and terms and conditions (collectively, "Standard Terms"); Purchasers of this part are entitled to the rights and benefits contained therein. For a full statement of the Standard Terms and the exclusive rights and remedies thereunder, please visit Mini-Circuits' website at www.minicircuits.com/MCLStore/terms.jsp

Case Style

QV

Outline Dimensions

QV2427

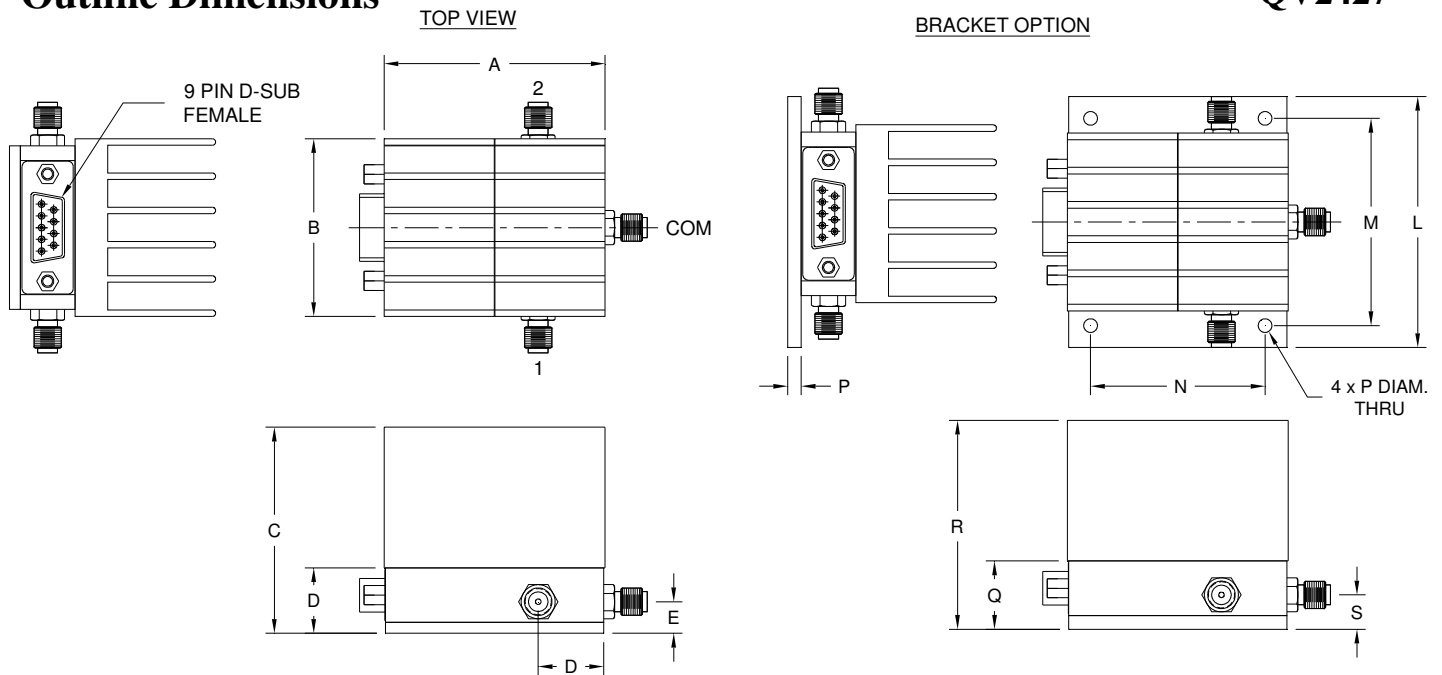

Mounting information for models without heatsink.

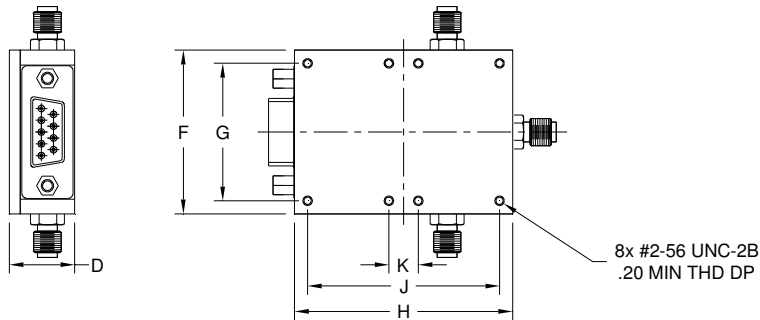

CASE#	A	B	C	D	E	F	G	H	J	K	L	M	N	P	Q
QV2427	2.025 (51.44)	1.63 (41.4)	1.89 (48.0)	.600 (15.24)	.29 (7.37)	1.500 (38.10)	1.260 (32.0)	2.000 (50.80)	1.760 (44.7)	.270 (6.86)	2.30 (58.4)	1.900 (48.3)	1.600 (40.6)	.125 (3.18)	.625 (15.9)

CASE#	R	S	WT. GRAMS
QV2427	1.915 (48.64)	.315 (8.0)	150

Dimensions are in inches (mm). Tolerances: 2PL. +/- .03; 3PL. +/- .015

Notes:

1. Case material: Aluminum alloy.
2. Case finish for RoHS Case Styles: Clear chemical conversion coating, non-chrome or trivalent chrome based.

Mini-Circuits[®]

INTERNET <http://www.minicircuits.com>

P.O. Box 350166, Brooklyn, New York 11235-0003 (718) 934-4500 Fax (718) 332-4661

Distribution Centers NORTH AMERICA 800-654-7949 • 417-335-5935 • Fax 417-335-5945 • EUROPE 44-1252-832600 • Fax 44-1252-837010

Mini-Circuits ISO 9001 & ISO 14001 Certified



All Mini-Circuits products are manufactured under exacting quality assurance and control standards, and are capable of meeting published specifications after being subjected to any or all of the following physical and environmental test.

Specification	Test/Inspection Condition	Reference/Spec
Operating Temperature	-40° to 85°C	Individual Model Data Sheet
Storage Temperature	-55° to 100° C Ambient Environment	Individual Model Data Sheet
Barometric Pressure	100,000 Feet	MIL-STD-202, Method 105, Condition D
Humidity	90% RH, 65°C Units may require bake-out after humidity to restore full performance.	MIL-STD-202, Method 103
Thermal Shock	-65° to 125°C, 5 cycles	MIL-STD-202, Method 107, Condition B
Vibration (High Frequency)	20g peak, 10-2000 Hz, 12 times in each of three perpendicular directions (total 36)	MIL-STD-202, Method 204, Condition D
Mechanical Shock	100g, 6ms sawtooth, 3 shocks each direction 3 axes (total 18)	MIL-STD-202, Method 213, Condition I