

High Power, DC Pass

# Power Splitter/Combiner ZN4PD1-63HP-S+

4 Way-0° 50Ω 30W 250 to 6000 MHz



CASE STYLE: UU846-4

## The Big Deal

- Wideband, 250 to 6000 MHz
- High power, up to 30W as a splitter
- Low insertion loss, 1.0 dB
- Low unbalance, 0.2 dB, 2°
- High isolation, up to 24 dB

## Product Overview

Mini-Circuits' ZN4PD1-63HP-S+ is a 4-way 0° high-power splitter/combiner providing 30W power handling as a splitter (2W as a combiner) and low insertion loss across the 250 to 6000 MHz frequency range. Its outstanding combination of high power handling and low loss minimize power dissipation and provide excellent signal fidelity from input to output. The ZN4PD1-63HP-S+ comes housed in a rugged aluminum alloy case measuring 3.5 x 4.5 x 0.65" with SMA connectors and all input/output ports on one side of the case, allowing easy cabling in tight layouts.

Feature	Advantages
Wideband, 250 to 6000 MHz	This model supports bandwidth requirements for a wide variety of applications.
High power handling: <ul style="list-style-type: none"><li>• 30W as a splitter</li><li>• 2.0W as a combiner</li></ul>	The ZN4PD1-63HP-S+ is suitable for a wide range of power requirements.
Low insertion loss, 1.0 dB	The combination of 30W power handling and low insertion loss makes this model a suitable candidate for distributing signals while maintaining excellent transmission of signal power.
Low unbalance: <ul style="list-style-type: none"><li>• 0.2 dB amplitude unbalance</li><li>• 2° phase unbalance</li></ul>	Produces nearly equal output signals, ideal for parallel path and multichannel systems.
DC Passing, 1.0A (250mA each port)	Supports applications where DC power is needed through the RF line.

### Notes

- A. Performance and quality attributes and conditions not expressly stated in this specification document are intended to be excluded and do not form a part of this specification document.  
B. Electrical specifications and performance data contained in this specification document are based on Mini-Circuit's applicable established test performance criteria and measurement instructions.  
C. The parts covered by this specification document are subject to Mini-Circuits standard limited warranty and terms and conditions (collectively, "Standard Terms"); Purchasers of this part are entitled to the rights and benefits contained therein. For a full statement of the Standard Terms and the exclusive rights and remedies thereunder, please visit Mini-Circuits' website at [www.minicircuits.com/MCLStore/terms.jsp](http://www.minicircuits.com/MCLStore/terms.jsp)



# Power Splitter/Combiner

## ZN4PD1-63HP-S+

4 Way-0° 50Ω 30W 250 to 6000 MHz

### Maximum Ratings

Operating Temperature(@<30W)	-55°C to 60°C
Operating Temperature(@<10W)	-55°C to 100°C
Storage Temperature	-55°C to 100°C
DC Current	1.0 A (250mA for each port)

Permanent damage may occur if any of these limits are exceeded.

### Coaxial Connections

SUM PORT	3
PORT 1	1
PORT 2	2
PORT 3	4
PORT 4	5

### Outline Drawing

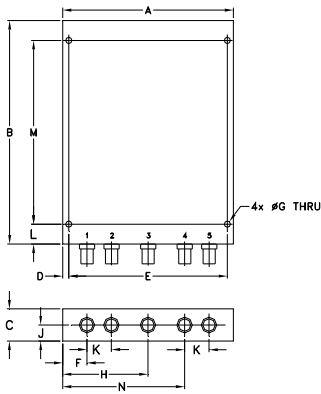

### Outline Dimensions (inch mm)

A	B	C	D	E	F	G
3.50	4.50	.65	.125	3.250	.50	.125
88.90	114.30	16.51	3.18	82.55	12.70	3.18
H	J	K	L	M	N	wt
1.75	.33	.50	.400	3.700	2.5	grams
44.45	8.38	12.70	10.16	93.98	63.50	288

### Features

- power handling up to 30 W
- wide frequency band, 250 to 6000 MHz
- low insertion loss, 1.0 dB typ.
- low amplitude unbalance 0.2 dB typ.
- low phase unbalance 2 deg. typ.

### Applications

- high band PCS
- UNII
- ISM 802.11A
- WiFi
- Bluetooth



Generic photo used for illustration purposes only

CASE STYLE: UU846-4

Connectors	Model
SMA	ZN4PD1-63HP-S+

### +RoHS Compliant

The +Suffix identifies RoHS Compliance. See our web site for RoHS Compliance methodologies and qualifications

### Electrical Specifications

Parameter	Frequency (MHz)	Min.	Typ.	Max.	Unit	
Frequency		250		6000	MHz	
Insertion Loss (above theoretical 6.0 dB)	250-400	—	0.4	0.8	dB	
	400-3000	—	0.8	1.4		
	3000-5700	—	1.3	2.2		
	5700-6000	—	1.8	2.5		
Isolation	250-400	8	15	—	dB	
	400-3000	16	22	—		
	3000-5700	18	24	—		
	5700-6000	13	17	—		
Phase Unbalance	250-400	—	0.5	3	Degree	
	400-3000	—	1.5	5		
	3000-5700	—	2	6		
	5700-6000	—	3	6		
Amplitude Unbalance	250-400	—	0.1	0.3	dB	
	400-3000	—	0.1	0.4		
	3000-5700	—	0.2	0.6		
	5700-6000	—	0.3	0.6		
VSWR (Port S)	250-400	—	1.20	1.7	:1	
	400-3000	—	1.25	1.7		
	3000-5700	—	1.25	1.65		
	5700-6000	—	1.4	1.7		
VSWR (Port 1-4)	250-400	—	1.1	1.25	:1	
	400-3000	—	1.2	1.5		
	3000-5700	—	1.2	1.45		
	5700-6000	—	1.25	1.55		
Power Handling <sup>3</sup>	As Splitter <sup>1</sup>	250-4000	—	—	30	W
	As Combiner <sup>2</sup>	4000-6000	—	—	20	
		250-6000	—	—	2.0	

1. All outputs must terminate 50 ohm (VSWR 1.5:1 or better)
2. As a combiner of non-coherent signals, max. power per port is 2.0 watt power rating divided by number of ports.
3. Alternative heat sinking and heat removal must be provided by the user to limit maximum base-plate temperature to 60°C, in order to ensure proper performance. For reference, this requires thermal resistance of user's external heat sink to be 10°C/W.

### Electrical Schematic

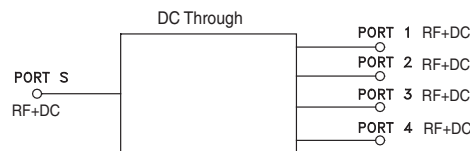

### Notes

- A. Performance and quality attributes and conditions not expressly stated in this specification document are intended to be excluded and do not form a part of this specification document.
- B. Electrical specifications and performance data contained in this specification document are based on Mini-Circuit's applicable established test performance criteria and measurement instructions.
- C. The parts covered by this specification document are subject to Mini-Circuits standard limited warranty and terms and conditions (collectively, "Standard Terms"); Purchasers of this part are entitled to the rights and benefits contained therein. For a full statement of the Standard Terms and the exclusive rights and remedies thereunder, please visit Mini-Circuits' website at [www.minicircuits.com/WCLStore/terms.jsp](http://www.minicircuits.com/WCLStore/terms.jsp)



# ZN4PD1-63HP-S+

## Typical Performance Data

Freq. (MHz)	Total Loss <sup>1</sup> (dB)				Amp. Unbal. (dB)	Isolation (dB)			Phase Unbal. (deg.)	VSWR S	VSWR 1	VSWR 2	VSWR 3	VSWR 4
	S-1	S-2	S-3	S-4		1-2	2-3	3-4						
250	6.40	6.36	6.35	6.35	0.05	11.89	18.90	11.82	0.23	1.49	1.07	1.07	1.06	1.06
400	6.37	6.34	6.33	6.34	0.04	21.39	26.45	21.75	0.17	1.35	1.16	1.16	1.16	1.16
700	6.37	6.34	6.32	6.33	0.05	23.24	27.03	22.36	0.30	1.08	1.24	1.24	1.24	1.24
1000	6.42	6.41	6.42	6.42	0.01	24.37	30.18	24.34	0.62	1.01	1.12	1.12	1.13	1.14
1500	6.59	6.59	6.57	6.58	0.02	20.62	25.73	20.57	0.96	1.23	1.06	1.06	1.05	1.05
2000	6.63	6.65	6.62	6.64	0.03	24.15	33.39	23.77	1.32	1.08	1.24	1.21	1.21	1.22
2500	6.77	6.83	6.77	6.78	0.06	44.09	43.72	43.16	1.62	1.22	1.25	1.23	1.21	1.23
3000	6.83	6.94	6.87	6.86	0.11	24.03	29.53	23.65	1.73	1.18	1.12	1.13	1.09	1.09
3500	6.97	7.10	7.01	7.00	0.12	35.32	30.41	31.77	2.27	1.34	1.25	1.28	1.25	1.24
4000	6.99	7.21	7.13	7.04	0.22	22.89	34.65	23.53	2.09	1.14	1.17	1.18	1.16	1.18
4500	7.06	7.29	7.22	7.08	0.23	22.65	39.05	25.15	2.81	1.06	1.13	1.15	1.16	1.15
5000	7.28	7.46	7.41	7.29	0.18	27.07	26.62	29.03	3.06	1.36	1.19	1.29	1.23	1.21
5500	7.34	7.58	7.54	7.31	0.27	27.94	41.81	25.91	3.25	1.20	1.07	1.02	1.06	1.10
5700	7.42	7.69	7.64	7.36	0.33	20.88	46.50	22.39	3.62	1.20	1.05	1.05	1.07	1.06
6000	7.79	8.12	8.11	7.76	0.37	16.56	23.92	15.96	3.39	1.47	1.36	1.36	1.36	1.33

1. Total Loss = Insertion Loss + 6dB splitter loss.

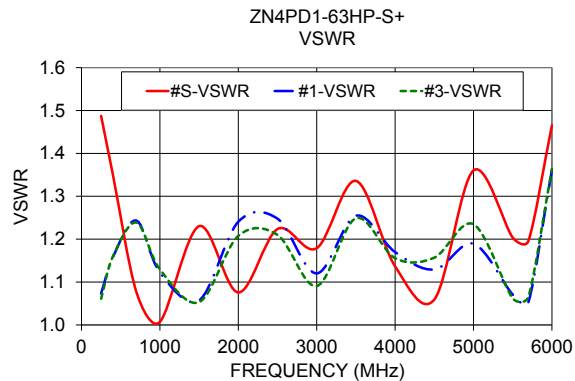
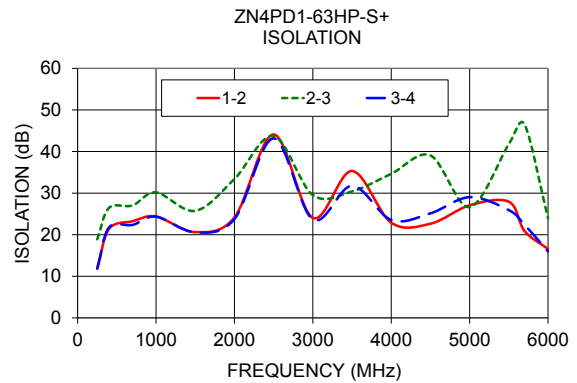
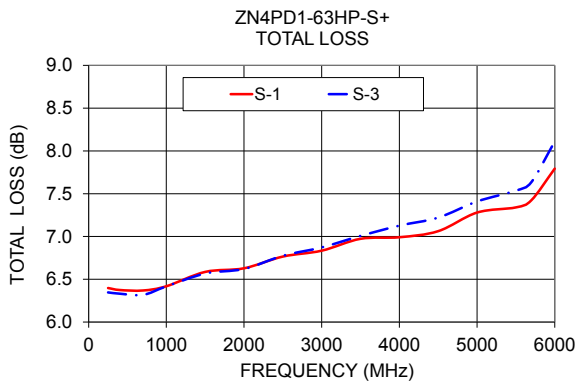

### Notes

- A. Performance and quality attributes and conditions not expressly stated in this specification document are intended to be excluded and do not form a part of this specification document.
- B. Electrical specifications and performance data contained in this specification document are based on Mini-Circuit's applicable established test performance criteria and measurement instructions.
- C. The parts covered by this specification document are subject to Mini-Circuits standard limited warranty and terms and conditions (collectively, "Standard Terms"); Purchasers of this part are entitled to the rights and benefits contained therein. For a full statement of the Standard Terms and the exclusive rights and remedies thereunder, please visit Mini-Circuits' website at [www.minicircuits.com/MCLStore/terms.jsp](http://www.minicircuits.com/MCLStore/terms.jsp)





# 4 Way-0° Power Splitter/Combiner

# ZN4PD1-63HP-S+

## Typical Performance Curves

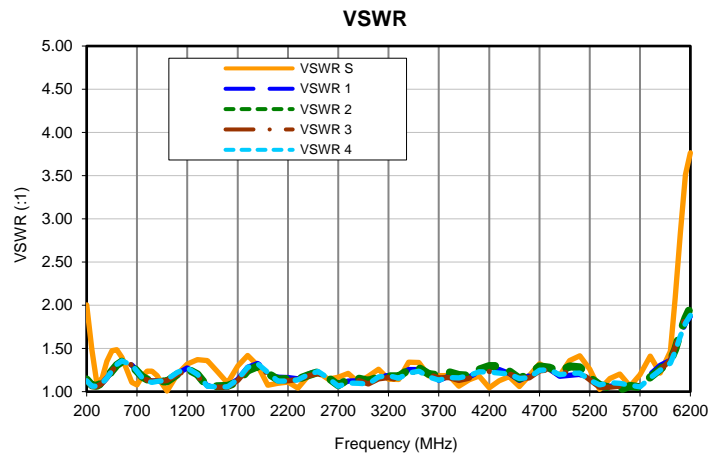
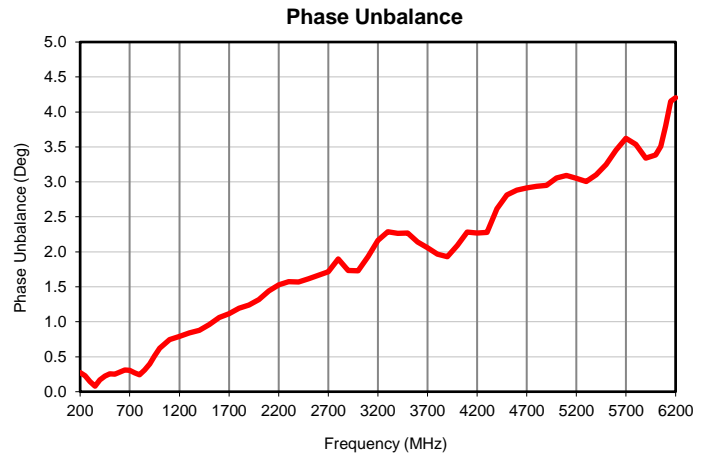
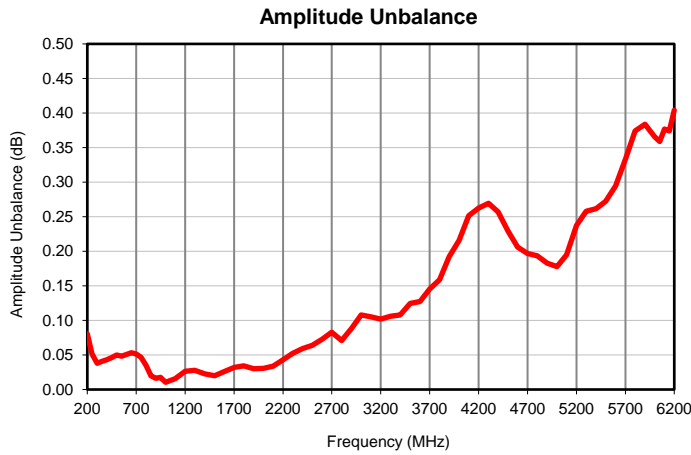
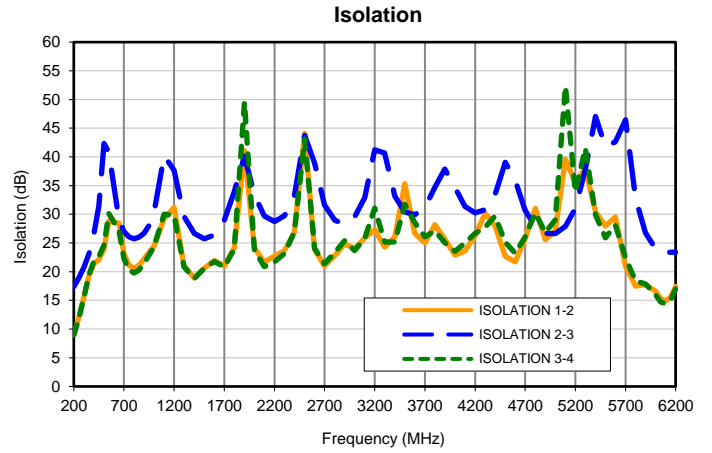
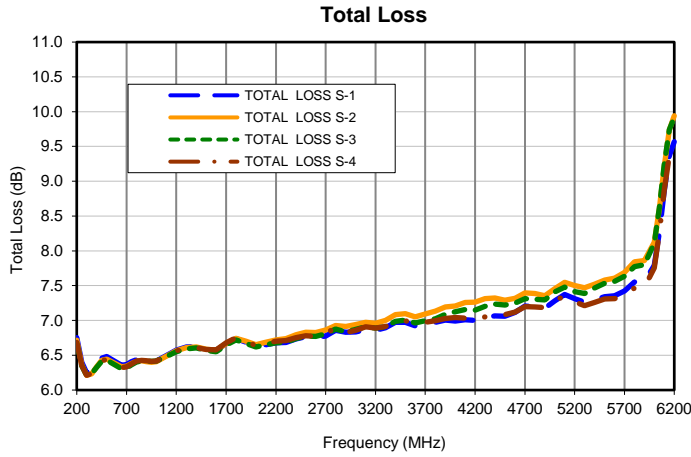

## Outline Dimensions

UU846-4

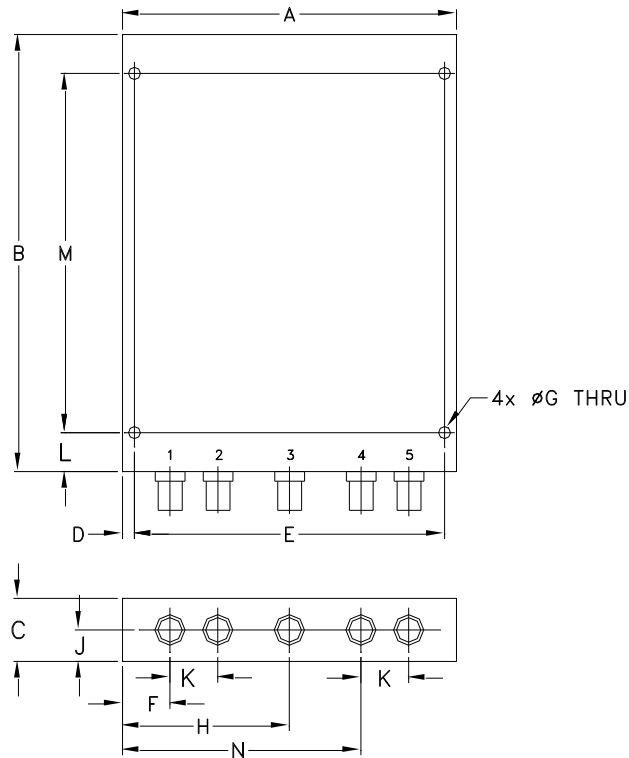

CASE #	A	B	C	D	E	F	G	H	J	K	L	M
UU846-4	3.50 (88.90)	4.50 (114.30)	.65 (16.51)	.125 (3.18)	3.250 (82.55)	.50 (12.70)	.125 (3.18)	1.75 (44.45)	.33 (8.38)	.500 (12.70)	.400 (10.16)	3.700 (93.98)

CASE #	N	WT. GRAMS
UU846-4	2.50 (63.50)	288

Dimensions are in inches (mm). Tolerances: 2 Pl.  $\pm .03$ ; 3 Pl.  $\pm .015$

### Notes:

- Case material: Aluminum alloy.
- Case finish:  
For RoHS Case Styles: Clear chemical conversion coating, non-chrome or trivalent chrome based.
- Refer to the individual model data sheet for the type of connectors available.



P.O. Box 350166, Brooklyn, New York 11235-0003 (718) 934-4500 Fax (718) 332-4661 For detailed performance specs & shopping online see Mini-Circuits web site



The Design Engineers Search Engine Provides ACTUAL Data Instantly From MINI-CIRCUITS At: [www.minicircuits.com](http://www.minicircuits.com)

RF/IF MICROWAVE COMPONENTS

All Mini-Circuits products are manufactured under exacting quality assurance and control standards, and are capable of meeting published specifications after being subjected to any or all of the following physical and environmental test.

<b>Specification</b>	<b>Test/Inspection Condition</b>	<b>Reference/Spec</b>
Operating Temperature	-55° to 100°C Ambient Environment	Individual Model Data Sheet
Storage Temperature	-55° to 100° C Ambient Environment	Individual Model Data Sheet
Barometric Pressure	100,000 Feet	MIL-STD-202, Method 105, Condition D
Humidity	90% RH, 65°C Units may require bake-out after humidity to restore full performance.	MIL-STD-202, Method 103
Thermal Shock	-65° to 125°C, 5 cycles	MIL-STD-202, Method 107, Condition B
Vibration (High Frequency)	20g peak, 10-2000 Hz, 12 times in each of three perpendicular directions (total 36)	MIL-STD-202, Method 204, Condition D
Mechanical Shock	100g, 6ms sawtooth, 3 shocks each direction 3 axes (total 18)	MIL-STD-202, Method 213, Condition I