

High Power, DC Pass

# Power Splitter/Combiner

## ZN2PD2-63A+

2 Way-0° 50Ω 25W 350 to 6000 MHz

### The Big Deal

- Wideband, 350 to 6000 MHz
- High power, up to 25W as a splitter
- Low insertion loss, 0.9 dB
- Low unbalance, 0.1 dB, 2°
- High isolation, 20 dB



CASE STYLE: F1908-3

### Product Overview

Mini-Circuits' ZN2PD2-63A-S+ is a 2-way 0° high-power splitter/combiner providing up to 25W power handling as a splitter (1.0W as a combiner) and low insertion loss across the entire 350 to 6000 MHz frequency range. Its outstanding combination of high power handling and low loss minimize power dissipation and provide excellent signal power transmission from input to output. The ZN2PD2-63A-S+ comes with N-Type and SMA version in a rugged aluminum alloy case measuring 4.0 x 3.25 x 0.875" with N-type or SMA connectors.

### Key Features

Feature	Advantages
Wideband, 350 to 6000 MHz	This model supports bandwidth requirements for a wide variety of applications.
High power handling: <ul style="list-style-type: none"><li>• 25W to 3600 MHz</li><li>• 15W to 6000 MHz</li></ul>	The ZN2PD2-63A-S+ is suitable for systems with a wide range of power requirements.
Low insertion loss, 0.9 dB	The combination of 25W power handling and low insertion loss makes this model a suitable candidate for distributing signals while maintaining excellent transmission of signal power.
Low unbalance: <ul style="list-style-type: none"><li>• 0.1 dB amplitude unbalance</li><li>• 2° phase unbalance</li></ul>	Produces nearly equal output signals, ideal for parallel path and multichannel systems.
High isolation, 20 dB	Minimizes interference between ports.
DC Passing, 600mA (300mA each port)	Supports applications where DC power is needed through the RF line.

#### Notes

- A. Performance and quality attributes and conditions not expressly stated in this specification document are intended to be excluded and do not form a part of this specification document.  
B. Electrical specifications and performance data contained in this specification document are based on Mini-Circuit's applicable established test performance criteria and measurement instructions.  
C. The parts covered by this specification document are subject to Mini-Circuits standard limited warranty and terms and conditions (collectively, "Standard Terms"); Purchasers of this part are entitled to the rights and benefits contained therein. For a full statement of the Standard Terms and the exclusive rights and remedies thereunder, please visit Mini-Circuits' website at [www.minicircuits.com/MCLStore/terms.jsp](http://www.minicircuits.com/MCLStore/terms.jsp)



High Power, DC Pass

# Power Splitter/Combiner

## ZN2PD2-63A+

2 Way-0° 50Ω 25W 350 to 6000 MHz

### Maximum Ratings

Operating Temperature(@ <math>\sim 25W</math>)	-55°C to 60°C
Operating Temperature(@ <math>< 10W</math>)	-55°C to 100°C
Storage Temperature	-55°C to 100°C
DC Current	600 mA (300mA for each port)

Permanent damage may occur if any of these limits are exceeded.

### Coaxial Connections

SUMPORT	S
PORT 1	1
PORT 2	2

### Outline Drawing

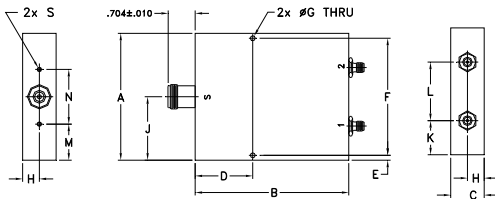

### Outline Dimensions (inch/mm)

A	B	C	D	E	F	G	H
3.25	4.00	.88	1.50	.13	3.00	.125	.44
82.55	101.60	22.35	38.10	3.30	76.20	3.18	11.18
J	K	L	M	N	S		wt
1.63	.88	1.500	.93	1.400	#4-40		grams
41.40	22.35	38.10	23.62	35.56	156 DP		300.0

### Features

- wideband, 350-6000 MHz
- excellent amplitude unbalance, 0.1 dB typ.
- good isolation, 20 dB typ.
- excellent phase unbalance, 2 deg. typ.
- up to 25W power input as splitter

### Applications

- UHF TV
- cellular/ISM/SMG/GSM
- satellite distribution
- GPS/L BAND (MARSAT)
- PCS/DCS/UMTS
- MMDC
- SATCOM



Generic photo used for illustration purposes only

CASE STYLE: F1908-3

Connectors	Model
SMA	ZN2PD2-63A-S+
N-Type	ZN2PD2-63A-N+

### +RoHS Compliant

The +Suffix identifies RoHS Compliance. See our web site for RoHS Compliance methodologies and qualifications

### Electrical Specifications at 25°C

Parameter	Frequency (MHz)	Min.	Typ.	Max.	Unit	
<b>Frequency</b>		350		6000	MHz	
<b>Insertion Loss (above theoretical 3.0 dB)</b>	350-500	—	0.3	0.6	dB	
	500-2700	—	0.5	0.9		
	2700-5200	—	0.8	1.1		
	5200-6000	—	0.9	1.4		
<b>Isolation</b>	350-500	16	20	—	dB	
	500-2700	18	22	—		
	2700-5200	17	20	—		
	5200-6000	15	18	—		
<b>Phase Unbalance</b>	350-2700	—	0.5	2	Degree	
	2700-3600	—	1.0	3		
	3600-6000	—	1.0	4		
<b>Amplitude Unbalance</b>	350-2700	—	0.15	0.3	dB	
	2700-6000	—	0.2	0.5		
<b>VSWR (Port S)</b>	350-6000	—	1.4	—	:1	
<b>VSWR (Port 1-2)</b>	350-6000	—	1.3	—		
<b>Power Handling<sup>3</sup></b>	<b>As Splitter<sup>1</sup></b>	350-3600	—	—	25	W
	<b>As Combiner<sup>2</sup></b>	3600-6000	—	—	15	
		350-6000	—	—	1.0	

1. All outputs must terminate 50 ohm (VSWR 1.5:1 or better)
2. As a combiner of non-coherent signals, max. power per port is 1.0 watt power rating divided by number of ports.
3. Alternative heat sinking and heat removal must be provided by the user to limit maximum base-plate temperature to 60°C, in order to ensure proper performance. For reference, this requires thermal resistance of user's external heat sink to be 10°C/W.

### Electrical Schematic

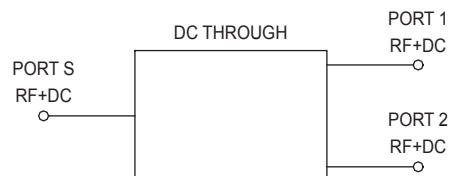

### Notes

- A. Performance and quality attributes and conditions not expressly stated in this specification document are intended to be excluded and do not form a part of this specification document.
- B. Electrical specifications and performance data contained in this specification document are based on Mini-Circuit's applicable established test performance criteria and measurement instructions.
- C. The parts covered by this specification document are subject to Mini-Circuit's standard limited warranty and terms and conditions (collectively, "Standard Terms"); Purchasers of this part are entitled to the rights and benefits contained therein. For a full statement of the Standard Terms and the exclusive rights and remedies thereunder, please visit Mini-Circuit's website at [www.minicircuits.com/MCLStore/terms.jsp](http://www.minicircuits.com/MCLStore/terms.jsp)



### Typical Performance Data

Frequency (MHz)	Total Loss <sup>1</sup> (dB)		Amplitude Unbalance (dB)	Isolation (dB)	Phase Unbalance (deg.)	VSWR S	VSWR 1	VSWR 2
	S-1	S-2						
350	3.30	3.31	0.01	18.30	0.01	1.44	1.16	1.16
500	3.20	3.21	0.01	42.15	0.04	1.15	1.15	1.15
1000	3.34	3.34	0.00	27.92	0.08	1.31	1.24	1.23
1600	3.48	3.49	0.01	23.01	0.09	1.46	1.38	1.36
2000	3.44	3.47	0.03	24.88	0.20	1.26	1.28	1.27
3500	3.57	3.61	0.04	22.27	0.10	1.20	1.27	1.25
4100	3.64	3.61	0.03	21.58	0.20	1.05	1.24	1.24
4600	3.67	3.70	0.04	28.78	0.27	1.20	1.30	1.29
5200	3.76	3.84	0.07	27.84	0.10	1.28	1.34	1.36
5500	3.78	3.77	0.01	19.88	0.04	1.03	1.23	1.21
6000	4.08	4.07	0.01	17.31	0.49	1.46	1.25	1.22

1. Total Loss = Insertion Loss + 3dB splitter loss.

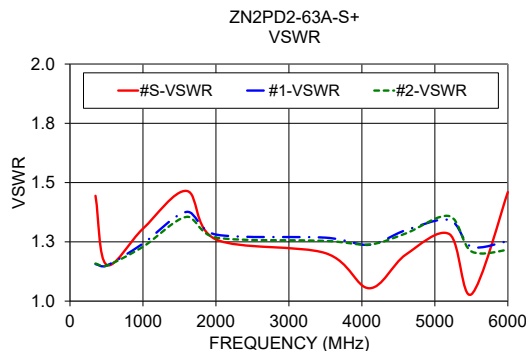
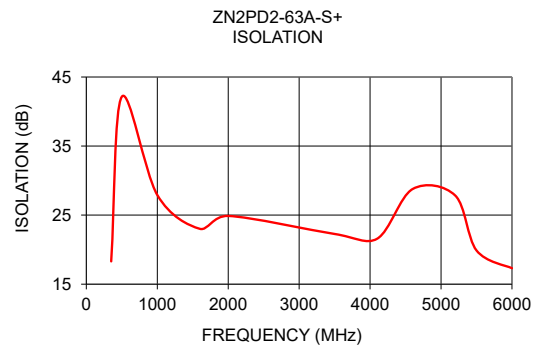
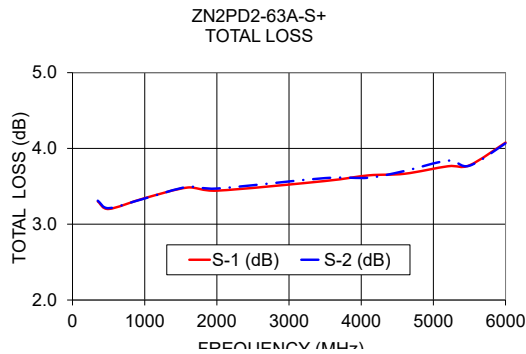

**Notes**

- A. Performance and quality attributes and conditions not expressly stated in this specification document are intended to be excluded and do not form a part of this specification document.
- B. Electrical specifications and performance data contained in this specification document are based on Mini-Circuit's applicable established test performance criteria and measurement instructions.
- C. The parts covered by this specification document are subject to Mini-Circuits standard limited warranty and terms and conditions (collectively, "Standard Terms"); Purchasers of this part are entitled to the rights and benefits contained therein. For a full statement of the Standard Terms and the exclusive rights and remedies thereunder, please visit Mini-Circuits' website at [www.minicircuits.com/MCLStore/terms.jsp](http://www.minicircuits.com/MCLStore/terms.jsp)



# 2 Way-0° Power Splitter/Combiner

# ZN2PD2-63A+

## Typical Performance Data

FREQUENCY (MHz)	TOTAL LOSS <sup>1</sup> (dB)		AMPLITUDE UNBALANCE (dB)	ISOLATION (dB)	PHASE UNBALANCE (deg.)	FREQUENCY (MHz)	VSWR (:1)		
	S-1	S-2					1-2	S	1
200	3.47	3.48	0.01	10.62	0.02	200	1.75	1.26	1.27
300	3.36	3.37	0.01	15.27	0.01	300	1.55	1.17	1.17
350	3.30	3.31	0.01	18.30	0.01	350	1.44	1.16	1.16
400	3.26	3.27	0.01	22.56	0.00	400	1.34	1.16	1.16
450	3.22	3.23	0.01	30.07	0.02	450	1.24	1.16	1.16
500	3.20	3.21	0.01	42.15	0.04	500	1.15	1.15	1.15
600	3.21	3.22	0.01	23.32	0.04	600	1.06	1.13	1.13
700	3.26	3.26	0.01	19.94	0.08	700	1.18	1.13	1.12
800	3.32	3.32	0.00	19.73	0.09	800	1.30	1.17	1.16
900	3.35	3.35	0.00	21.92	0.11	900	1.34	1.22	1.21
1000	3.34	3.34	0.00	27.92	0.08	1000	1.31	1.24	1.23
1100	3.32	3.31	0.01	35.44	0.08	1100	1.19	1.22	1.21
1200	3.31	3.30	0.01	25.06	0.06	1200	1.06	1.18	1.17
1400	3.42	3.42	0.00	20.23	0.05	1400	1.33	1.25	1.23
1600	3.48	3.49	0.01	23.01	0.09	1600	1.46	1.38	1.36
1800	3.42	3.44	0.02	31.20	0.15	1800	1.28	1.33	1.32
2000	3.44	3.47	0.03	24.88	0.20	2000	1.26	1.28	1.27
2200	3.57	3.59	0.02	24.13	0.18	2200	1.48	1.39	1.39
2400	3.56	3.57	0.01	33.06	0.12	2400	1.41	1.39	1.41
2600	3.48	3.49	0.00	27.19	0.07	2600	1.14	1.23	1.26
2700	3.50	3.51	0.01	24.22	0.04	2700	1.16	1.23	1.23
2800	3.54	3.55	0.02	23.58	0.02	2800	1.26	1.29	1.29
2900	3.55	3.58	0.03	24.15	0.04	2900	1.31	1.36	1.35
3000	3.54	3.58	0.04	24.16	0.08	3000	1.30	1.39	1.40
3100	3.53	3.57	0.04	22.50	0.12	3100	1.24	1.39	1.40
3200	3.53	3.58	0.05	20.60	0.11	3200	1.21	1.37	1.38
3300	3.55	3.60	0.05	19.77	0.10	3300	1.22	1.34	1.34
3400	3.57	3.62	0.05	20.27	0.01	3400	1.23	1.31	1.30
3500	3.57	3.61	0.04	22.27	0.10	3500	1.20	1.27	1.25
3600	3.56	3.59	0.03	25.16	0.20	3600	1.14	1.22	1.21
3700	3.56	3.59	0.03	25.74	0.23	3700	1.09	1.20	1.20
3900	3.61	3.60	0.01	22.10	0.24	3900	1.09	1.23	1.25
4100	3.64	3.61	0.03	21.58	0.20	4100	1.05	1.24	1.24
4300	3.66	3.65	0.02	23.46	0.05	4300	1.02	1.17	1.15
4600	3.67	3.70	0.04	28.78	0.27	4600	1.20	1.30	1.29
4900	3.63	3.72	0.09	21.67	0.18	4900	1.01	1.19	1.19
5200	3.76	3.84	0.07	27.84	0.10	5200	1.28	1.34	1.36
5500	3.78	3.77	0.01	19.88	0.04	5500	1.03	1.23	1.21
5800	3.88	3.83	0.05	20.87	0.31	5800	1.12	1.21	1.15
6000	4.08	4.07	0.01	17.31	0.49	6000	1.46	1.25	1.22
6200	4.08	4.13	0.05	14.25	0.83	6200	1.49	1.39	1.37

<sup>1</sup>Total Loss = Insertion Loss + 3dB Splitter Loss



## Typical Performance Curves

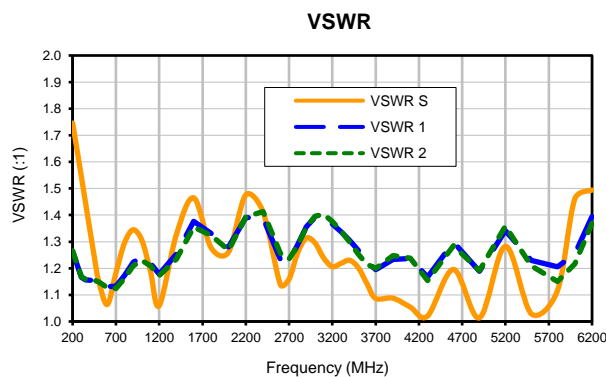
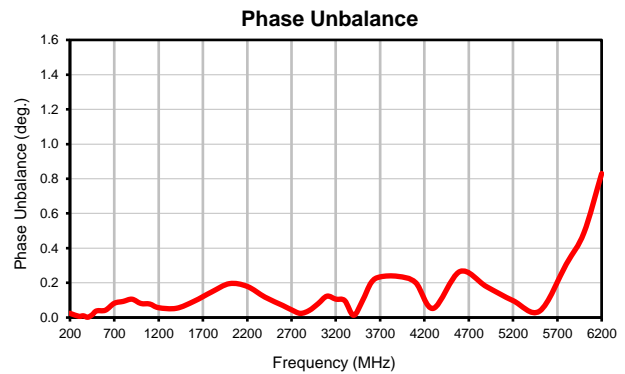
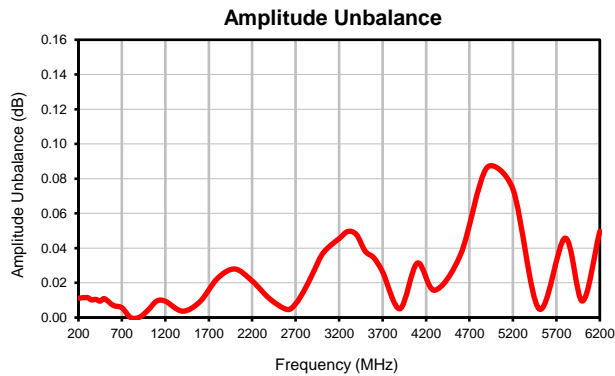
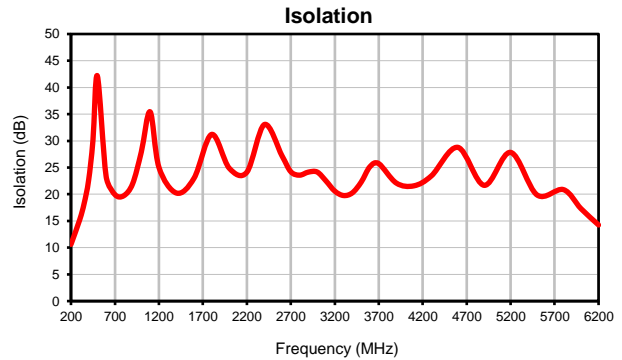
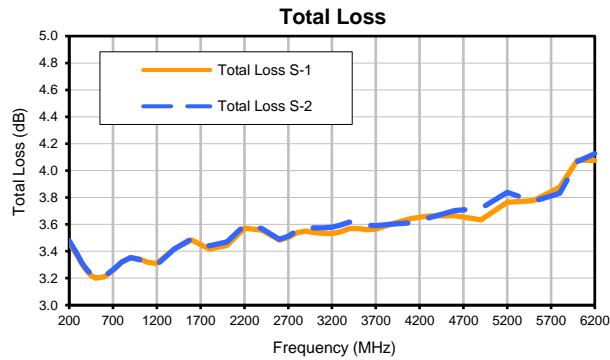

# Case Style

# F

## F1908-3

### Outline Dimensions

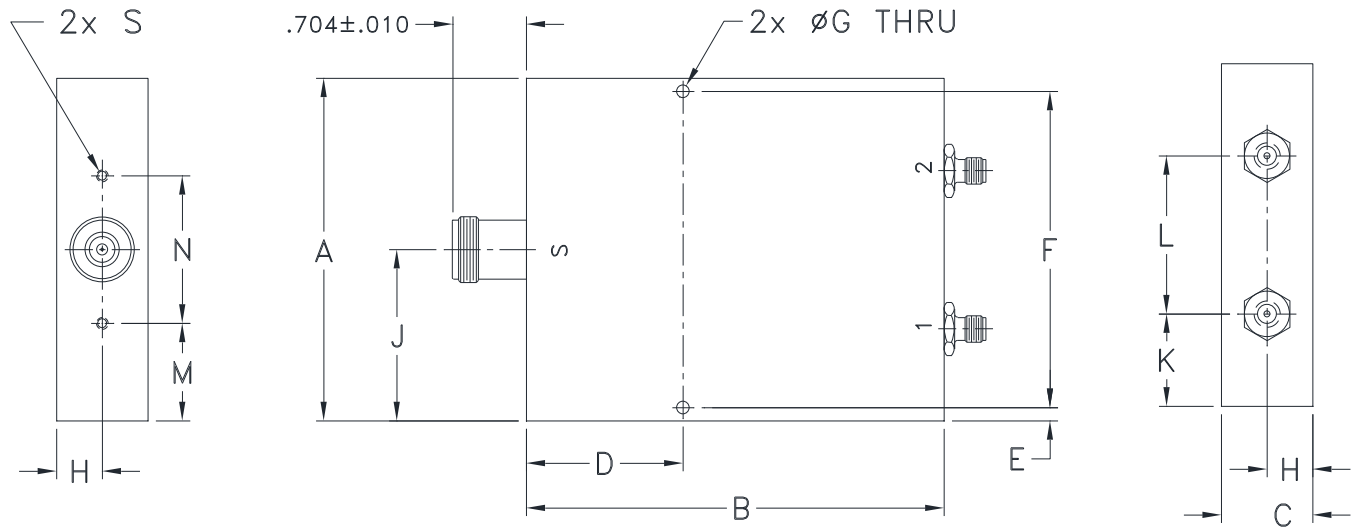

CASE #	A	B	C	D	E	F	G	H	J	K	L	M
F1908-3	3.25 (82.55)	4.00 (101.60)	.88 (22.35)	1.50 (38.10)	.13 (3.18)	3.000 (76.20)	.125 (3.18)	.44 (11.18)	1.63 (41.40)	.88 (22.35)	1.500 (38.10)	.93 (23.62)

CASE #	N	P	Q	R	S	WT. GRAM
F1908-3	1.400 (35.56)	-	-	-	#4-40, .156 DP	300.0

Dimensions are in inches (mm). Tolerances: 2Pl. ± .03; 3Pl. ± .015

#### Notes:

- Case material: Aluminum alloy.
- Case finish:  
For RoHS Case Styles: Clear chemical conversion coating, non-chrome or trivalent chrome based.
- Refer to the individual model data sheet for the type of connectors available.

**Mini-Circuits®**

Distribution Centers NORTH AMERICA 800-654-7949 • 417-335-5935 • Fax 417-335-5945 • EUROPE 44-1252-832600 • Fax 44-1252-837010

Mini-Circuits ISO 9001 & ISO 14001 Certified

INTERNET <http://www.minicircuits.com>

P.O. Box 350166, Brooklyn, New York 11235-0003 (718) 934-4500 Fax (718) 332-4661



All Mini-Circuits products are manufactured under exacting quality assurance and control standards, and are capable of meeting published specifications after being subjected to any or all of the following physical and environmental test.

<b>Specification</b>	<b>Test/Inspection Condition</b>	<b>Reference/Spec</b>
Operating Temperature	-55° to 100°C Ambient Environment	Individual Model Data Sheet
Storage Temperature	-55° to 100° C Ambient Environment	Individual Model Data Sheet
Barometric Pressure	100,000 Feet	MIL-STD-202, Method 105, Condition D
Humidity	90% RH, 65°C Units may require bake-out after humidity to restore full performance.	MIL-STD-202, Method 103
Thermal Shock	-65° to 125°C, 5 cycles	MIL-STD-202, Method 107, Condition B
Vibration (High Frequency)	20g peak, 10-2000 Hz, 12 times in each of three perpendicular directions (total 36)	MIL-STD-202, Method 204, Condition D
Mechanical Shock	100g, 6ms sawtooth, 3 shocks each direction 3 axes (total 18)	MIL-STD-202, Method 213, Condition I