

DC Pass Power Splitter/Combiner

ZN2PD-K44+

2 Way-0° 50Ω 10 to 40 GHz

The Big Deal

- Ultra-wideband, 10 to 40 GHz
- Low insertion loss, 0.8 dB
- High Isolation, 20 dB
- 10W power handling
- Low amplitude unbalance, 0.2 dB



CASE STYLE: UU2234-1

Product Overview

Mini-Circuits' ZN2PD-K44+ is an ultra-wideband coaxial 2-way 0° splitter/combiner providing coverage from 10 to 40 GHz, supporting a wide range of applications including 5G, Ku-Band, K-Band, and Ka-Band SatCom, microwave point-to-point backhaul, instrumentation and many more. This model provides 10W power handling as a splitter and very low insertion loss across the entire operating frequency range, minimizing power dissipation and delivering excellent signal power transmission from input to output. The ZN2PD-K44+ comes housed in a rugged aluminum alloy case measuring 1.0 x 1.0 x 0.37" with 2.92mm connectors.

Key Features

Feature	Advantages
Ultra-wideband, 10 to 40 GHz	Extremely wide frequency range supports many broadband applications in a single model.
Low insertion loss, 0.8 dB	The combination of 10W power handling and low insertion loss makes this model a suitable candidate for distributing signals while maintaining excellent transmission of signal power.
High isolation, 20 dB	Minimizes interference between ports.
High power handling: <ul style="list-style-type: none">• 10W as a splitter• 1W as a combiner	The ZN2PD-K44+ is suitable for systems with a wide range of power requirements.
Low amplitude unbalance, 0.2 dB	Produces nearly equal output signals, ideal for parallel path and multichannel systems.
DC Passing, 600mA (300mA each port)	Supports applications where DC power is needed through the RF line.

Notes

- A. Performance and quality attributes and conditions not expressly stated in this specification document are intended to be excluded and do not form a part of this specification document.
B. Electrical specifications and performance data contained in this specification document are based on Mini-Circuit's applicable established test performance criteria and measurement instructions.
C. The parts covered by this specification document are subject to Mini-Circuits standard limited warranty and terms and conditions (collectively, "Standard Terms"); Purchasers of this part are entitled to the rights and benefits contained therein. For a full statement of the Standard Terms and the exclusive rights and remedies thereunder, please visit Mini-Circuits' website at www.minicircuits.com/MCLStore/terms.jsp



Power Splitter/Combiner

ZN2PD-K44+

2 Way-0° 50Ω 10 to 40 GHz



Generic photo used for illustration purposes only
CASE STYLE: UU2234-1

Connectors	Model
2.92mm Female	ZN2PD-K44+

+RoHS Compliant
The +Suffix identifies RoHS Compliance. See our web site for RoHS Compliance methodologies and qualifications

Maximum Ratings

Operating Temperature	-55°C to 100°C
Storage Temperature	-55°C to 100°C
Power Input (as a splitter)*	10W max.
Internal Dissipation	1W max.

DC Current 600 mA (300mA for each port)
Permanent damage may occur if any of these limits are exceeded.
*Assume output match of 2.0:1 or better.

Coaxial Connections

SUM PORT	S
PORT 1	1
PORT 2	2

Outline Drawing

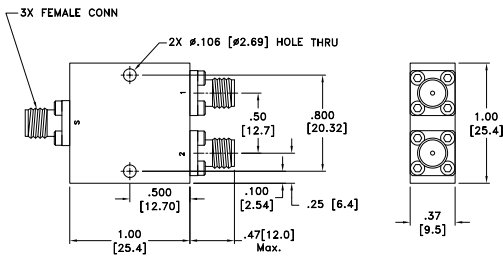

Weight: 35 grams MAX
Dimensions in inches [mm]. Tolerances: 2 Pl. ±.03[.76]; 3 Pl. ±.010[.25] Inches[mm]

Features

- wideband, 10 to 40 GHz
- excellent amplitude unbalance, 0.2 dB typ.
- excellent insertion loss 0.8dB typ.
- up to 10W power input as splitter

Applications

- WIMAX
- instruments
- satellite distribution
- WLAN
- LTE
- radar

Electrical Specifications at 25°C

Parameter	Frequency (GHz)	Min.	Typ.	Max.	Unit
Frequency Range		10		40	GHz
Insertion Loss Above 3.0 dB	10 - 18	—	0.5	1.2	dB
	18 - 26.5	—	0.7	1.8	
	26.5 - 40	—	1.0	2.0	
Isolation	10 - 40	15	31	—	dB
Phase Unbalance	10 - 18	—	0.8	7.0	Degree
	18 - 26.5	—	1.3	9.0	
	26.5 - 40	—	1.8	10.0	
Amplitude Unbalance	10 - 18	—	0.02	0.3	dB
	18 - 26.5	—	0.04	0.4	
	26.5 - 40	—	0.05	0.6	
VSWR (Port S)	10 - 18	—	1.10	1.8	:1
	18 - 26.5	—	1.17	1.8	
	26.5 - 40	—	1.11	1.8	
VSWR (Port 1-2)	10 - 18	—	1.13	1.8	:1
	18 - 26.5	—	1.19	1.8	
	26.5 - 40	—	1.13	1.8	

Typical Performance Data

Frequency (GHz)	Total Loss ¹ (dB)		Amplitude Unbalance (dB)	Isolation (dB)	Phase Unbalance (deg.)	VSWR S	VSWR 1	VSWR 2
	S-1	S-2						
10	3.40	3.40	0.02	25.27	0.63	1.09	1.08	1.10
14	3.52	3.51	0.03	36.35	0.86	1.14	1.19	1.17
15	3.54	3.53	0.03	30.48	0.90	1.11	1.21	1.19
16	3.55	3.54	0.03	26.17	0.90	1.05	1.15	1.14
17	3.59	3.59	0.02	25.73	0.98	1.17	1.09	1.09
18	3.61	3.61	0.02	28.27	1.07	1.17	1.07	1.06
19	3.61	3.61	0.02	35.76	1.13	1.04	1.05	1.06
20	3.67	3.67	0.03	36.10	1.20	1.20	1.20	1.20
25	3.83	3.82	0.04	37.14	1.36	1.21	1.23	1.21
26	3.80	3.80	0.04	37.75	1.40	1.10	1.12	1.12
27	3.82	3.82	0.03	33.08	1.47	1.06	1.04	1.07
30	3.90	3.90	0.04	29.98	1.65	1.04	1.09	1.09
35	4.05	4.05	0.05	30.03	1.84	1.12	1.15	1.13
40	4.23	4.23	0.09	31.24	2.00	1.09	1.26	1.22

1. Total Loss = Insertion Loss + 3dB splitter loss.

Electrical Schematic

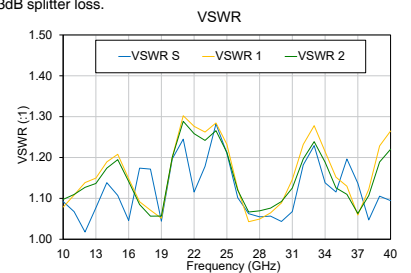
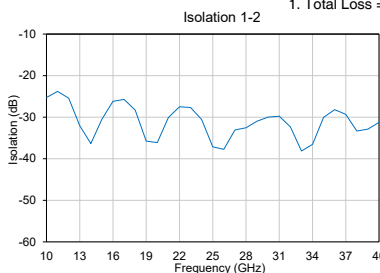
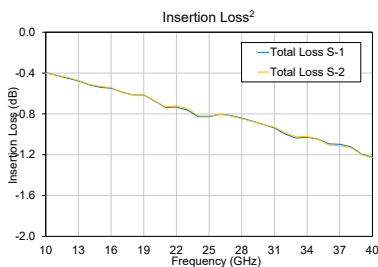
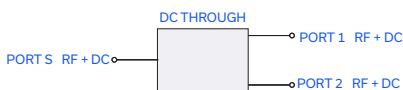

Notes

- Performance and quality attributes and conditions not expressly stated in this specification document are intended to be excluded and do not form a part of this specification document.
- Electrical specifications and performance data contained in this specification document are based on Mini-Circuit's applicable established test performance criteria and measurement instructions.
- The parts covered by this specification document are subject to Mini-Circuits standard limited warranty and terms and conditions (collectively, "Standard Terms"); Purchasers of this part are entitled to the rights and benefits contained therein. For a full statement of the Standard Terms and the exclusive rights and remedies thereunder, please visit Mini-Circuits' website at www.minicircuits.com/MCLStore/terms.jsp



2 Way-0° Power Splitter/Combiner

ZN2PD-K44+

Typical Performance Data

FREQUENCY (MHz)	TOTAL LOSS ¹ (dB)		AMPLITUDE UNBALANCE (dB)	ISOLATION (dB)	PHASE UNBALANCE (deg.)	FREQUENCY (MHz)	VSWR (:1)		
	S-1	S-2					S	1	2
10000	3.55	3.54	0.01	19.21	0.00	10000	1.43	1.28	1.30
11000	3.54	3.54	0.01	21.39	0.09	11000	1.37	1.32	1.36
12000	3.53	3.53	0.01	23.86	0.23	12000	1.26	1.32	1.33
13000	3.56	3.53	0.03	26.67	0.23	13000	1.24	1.38	1.35
14000	3.68	3.63	0.04	29.61	0.16	14000	1.41	1.54	1.52
15000	3.70	3.65	0.05	31.61	0.09	15000	1.31	1.56	1.54
16000	3.64	3.59	0.05	31.50	0.06	16000	1.09	1.44	1.40
17000	3.63	3.60	0.03	28.79	0.20	17000	1.20	1.24	1.20
18000	3.74	3.75	0.01	25.37	0.08	18000	1.32	1.06	1.01
19000	3.74	3.74	0.00	22.59	0.21	19000	1.23	1.14	1.11
20000	3.73	3.69	0.04	20.49	0.28	20000	1.17	1.25	1.18
21000	3.82	3.75	0.07	19.05	0.10	21000	1.11	1.26	1.16
22000	3.83	3.77	0.06	18.03	0.06	22000	1.11	1.08	1.02
23000	3.93	3.88	0.05	17.44	0.00	23000	1.27	1.24	1.17
24000	3.99	3.91	0.07	17.24	0.06	24000	1.33	1.39	1.24
25000	3.97	3.90	0.07	17.37	0.35	25000	1.24	1.36	1.24
26000	3.99	3.97	0.02	17.73	0.48	26000	1.17	1.27	1.23
27000	3.95	3.97	0.02	18.32	0.13	27000	1.13	1.08	1.16
28000	4.01	3.99	0.02	19.03	0.37	28000	1.18	1.15	1.08
29000	4.04	3.93	0.11	20.04	0.36	29000	1.13	1.29	1.14
30000	4.10	3.94	0.16	21.45	0.17	30000	1.07	1.51	1.31
31000	4.07	3.94	0.13	23.42	0.86	31000	1.17	1.65	1.46
32000	4.03	3.99	0.04	26.18	1.03	32000	1.22	1.45	1.37
33000	4.10	4.12	0.02	29.56	0.75	33000	1.23	1.20	1.24
34000	4.18	4.21	0.03	28.67	0.33	34000	1.18	1.03	1.11
35000	4.38	4.36	0.01	25.97	0.13	35000	1.45	1.20	1.04
35500	4.46	4.43	0.03	23.92	0.10	35500	1.54	1.23	1.11
36000	4.49	4.43	0.05	23.06	0.15	36000	1.58	1.16	1.17
36500	4.47	4.40	0.06	23.27	0.26	36500	1.56	1.06	1.14
37000	4.40	4.32	0.08	24.31	0.35	37000	1.46	1.10	1.08
37500	4.30	4.20	0.10	26.04	0.51	37500	1.34	1.24	1.09
38000	4.28	4.18	0.10	28.81	0.66	38000	1.37	1.39	1.21
38500	4.33	4.24	0.09	32.62	0.96	38500	1.59	1.54	1.37
39000	4.44	4.37	0.07	37.86	1.15	39000	1.80	1.65	1.51
39500	4.50	4.48	0.03	42.50	1.30	39500	1.84	1.70	1.61
40000	4.59	4.60	0.01	35.08	1.31	40000	1.69	1.65	1.64
41000	4.46	4.52	0.06	29.38	0.98	41000	1.19	1.41	1.47
41800	4.38	4.43	0.05	25.60	0.70	41800	1.20	1.17	1.22
42600	4.61	4.62	0.01	23.13	0.70	42600	1.51	1.15	1.17
43500	4.66	4.70	0.04	21.63	0.92	43500	1.43	1.09	1.10

¹Total Loss = Insertion Loss + 3dB Splitter Loss



2 Way-0° Power Splitter/Combiner

ZN2PD-K44+

Typical Performance Curves

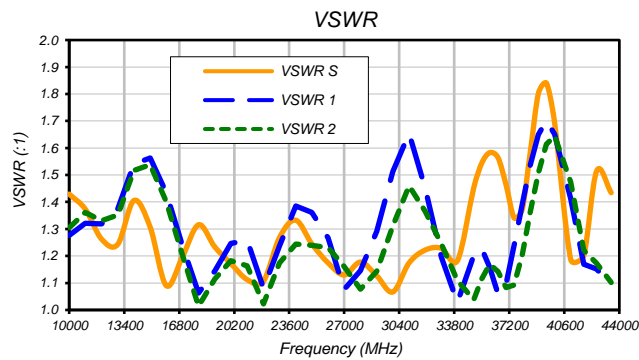
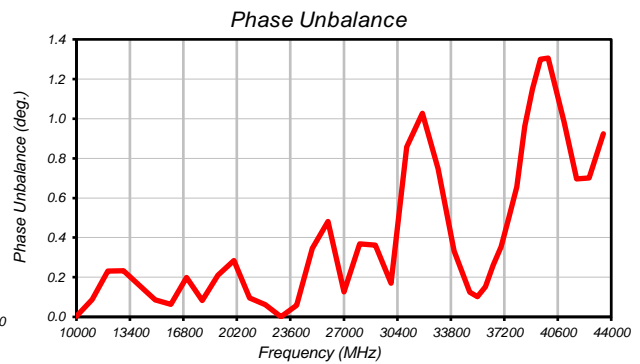
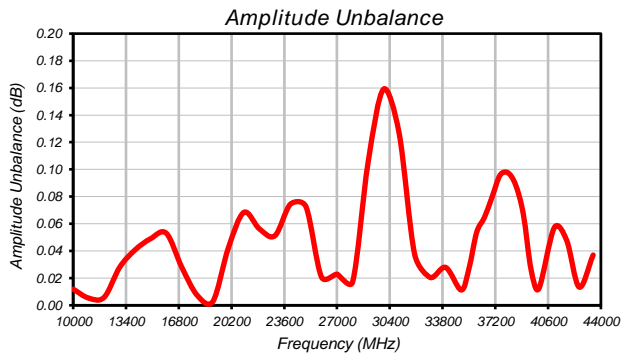
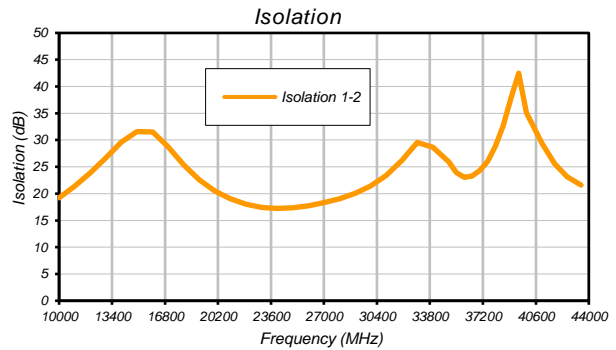
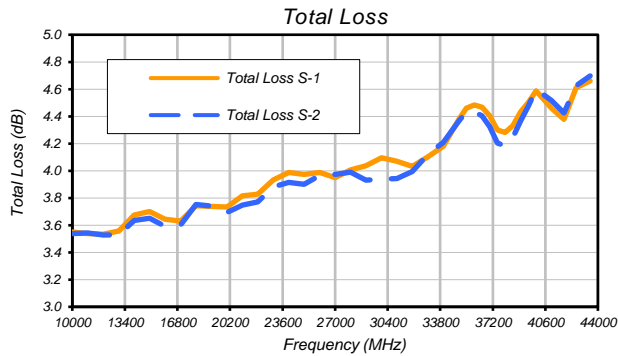

P.O. Box 350166, Brooklyn, New York 11235-0003 (718) 934-4500 • Fax (718) 332-4661 For detailed performance specs & shopping online see Mini-Circuits web site



The Design Engineers Search Engine Provides ACTUAL Data Instantly From MINI-CIRCUITS At: www.minicircuits.com

IF/RF MICROWAVE COMPONENTS

REV. OR
ZN2PD-K44+
11/22/2016
Page 1 of 1

Case Style

UU

Outline Dimensions

UU2234-1

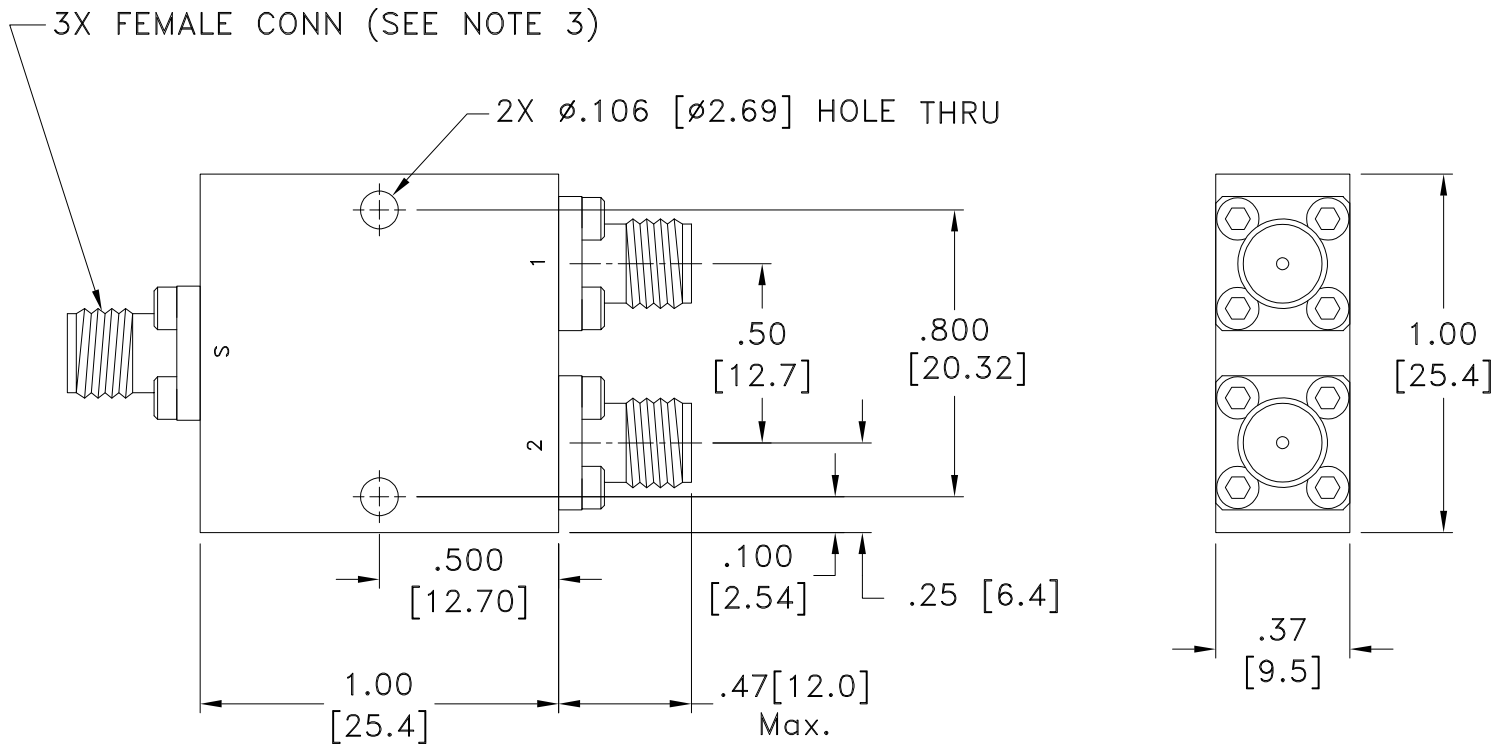

Weight: 35 grams MAX

Dimensions are in inches [mm]. Tolerances: 2 Pl. \pm .03 [.76]; 3 Pl. \pm .010 [.25] Inches [mm]

Notes:

1. Case material: Aluminum Alloy.
2. Case Finish: Nickel plating
3. Refer to the individual model data sheet for the type of connectors available.

Mini-Circuits[®]
ISO 9001 ISO 14001 CERTIFIED

ALL NEW
minicircuits.com

P.O. Box 350166, Brooklyn, New York 11235-0003 (718) 934-4500 Fax (718) 332-4661 For detailed performance specs & shopping online see Mini-Circuits web site



The Design Engineers Search Engine Provides ACTUAL Data Instantly From MINI-CIRCUITS At: www.minicircuits.com

RF/IF MICROWAVE COMPONENTS

All Mini-Circuits products are manufactured under exacting quality assurance and control standards, and are capable of meeting published specifications after being subjected to any or all of the following physical and environmental test.

Specification	Test/Inspection Condition	Reference/Spec
Operating Temperature	-55° to 100°C Ambient Environment	Individual Model Data Sheet
Storage Temperature	-55° to 100° C Ambient Environment	Individual Model Data Sheet
Barometric Pressure	100,000 Feet	MIL-STD-202, Method 105, Condition D
Humidity	90% RH, 65°C Units may require bake-out after humidity to restore full performance.	MIL-STD-202, Method 103
Thermal Shock	-65° to 125°C, 5 cycles	MIL-STD-202, Method 107, Condition B
Vibration (High Frequency)	20g peak, 10-2000 Hz, 12 times in each of three perpendicular directions (total 36)	MIL-STD-202, Method 204, Condition D
Mechanical Shock	100g, 6ms sawtooth, 3 shocks each direction 3 axes (total 18)	MIL-STD-202, Method 213, Condition I