



TTL

Mechanical Switch

ZK-MSP6TA-12

Mini-Circuits

50 Ω DC to 12 GHz SP6T SMA-Female

THE BIG DEAL

- Mechanical SP6T absorptive switch
- TTL interface for simple control integration
- Fail-safe/redundancy switching
- LED switch state indicators
- High isolation
- Low insertion loss

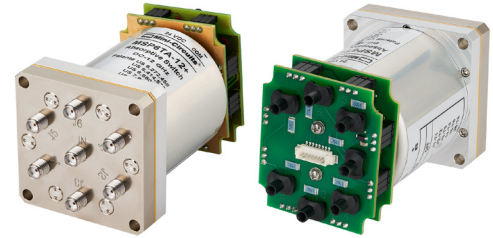

Front View

Back View

Generic photo used for illustration purposes only

APPLICATIONS

- RF signal routing/switch matrices
- Automated test & measurement systems
- 5G FR1, WiFi 6E, UWB, Bluetooth
- Military radio, radar & electronic warfare
- Harmonic testing

FUNCTIONAL BLOCK DIAGRAM

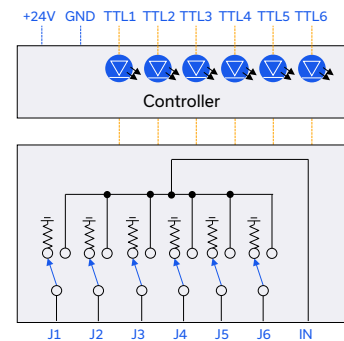

PRODUCT OVERVIEW

Mini-Circuits' ZK-MSP6TA-12 is an ultra-reliable electro-mechanical SP6T switch operating over a wide bandwidth from DC to 12 GHz with high isolation and low insertion loss. The switch is absorptive and fail-safe with a break before make configuration and lifetime of 10 million switching cycles when used within the noted specifications. All RF connections (SMA female) are conveniently grouped together on the front of the switch.

Simple control via TTL voltage levels allows integration with a wide range of microcontroller, embedded or custom systems without the additional complexity of USB or Ethernet control from a PC. The 6 TTL control inputs and +24V DC supply connections are accessed through a single 8-pin PCB header connector on the rear of the switch. LED indicators are also included on the rear of the package to give a convenient visual read out of the current switch state. LED light-pipe connectors allow the indicators to be routed to wherever they are needed when the switch is integrated into a final product.

KEY FEATURES

Feature	Advantages
Mechanical switch	Mechanical absorptive switches provide low loss, high isolation, high reliability, repeatable performance and internal termination of input signals on the disconnected paths
High repeatability	The high repeatability of switching cycles ensures reliable performance, critical for automated testing and other measurement applications.
Fail-safe design	The switch reverts to a known default state when the DC supply is removed, allowing their use in systems that must continue to operate safely in the event of power failure
Break-before-make configuration	Prevents a momentary connection of the old and new signal paths, reducing the inconsistent transient effects that could otherwise be observed during switching
TTL control	Simple control via TTL logic levels allows integration with a wide range of microcontroller, embedded, or custom systems.

Mini-Circuits



TTL

Mechanical Switch

ZK-MSP6TA-12

Mini-Circuits

50 Ω DC to 12 GHz SP6T SMA-Female

ELECTRICAL SPECIFICATIONS AT +25°C

Parameter	Conditions	Min.	Typ.	Max.	Units
Frequency Range		DC		12	GHz
Insertion Loss	DC - 6 GHz		0.15	0.25	dB
	6 - 8 GHz		0.20	0.30	
	8 - 12 GHz		0.25	0.45	
Isolation (Inactive Paths) ¹	DC - 6 GHz	80	95		dB
	6 - 8 GHz	80	90		
	8 - 12 GHz	80	90		
Return Loss ²	DC - 6 GHz		20		dB
	6 - 8 GHz		20		
	8 - 12 GHz		20		
Switching Time			25		ms
RF Input Power (Cold Switching)	Through path			20	W
	Into internal termination			1	
Switch Lifetime	100 mW hot switching ³	10			million cycles
	1W hot switching		1		

1. Isolation measured between Com and any disconnected port. Example: Isolation for Com to 1 is the leakage measured at port 1 from a signal input at Com when the active switch path is set to Com to 2

2. Return loss into Com when active or ports 1-6 in any state; Com is reflective when disconnected

3. Hot switching power above this level will degrade the switch's lifetime



TTL

Mechanical Switch

ZK-MSP6TA-12

Mini-Circuits

50 Ω DC to 12 GHz SP6T SMA-Female

TYPICAL PERFORMANCE CURVES

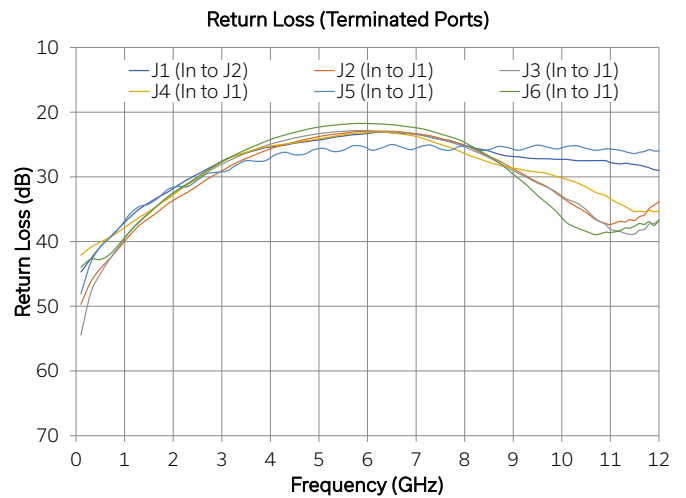
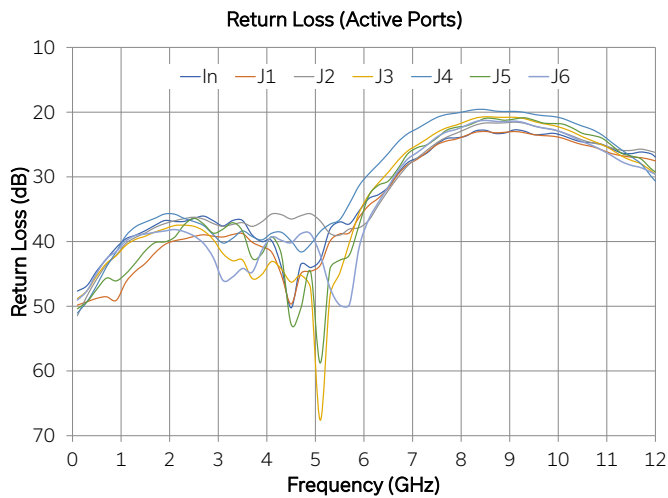
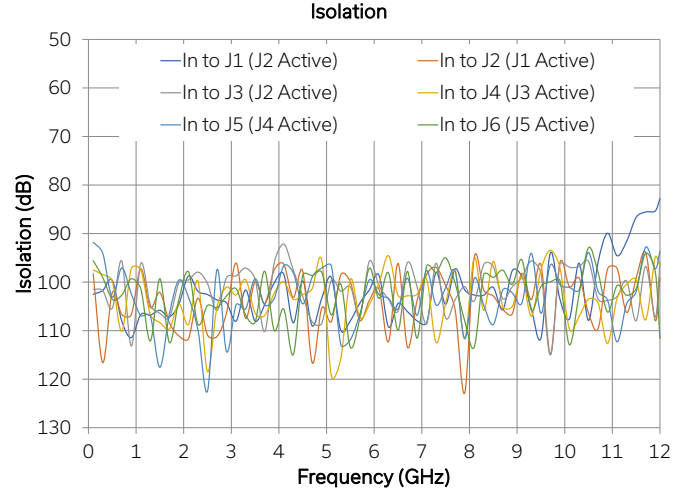
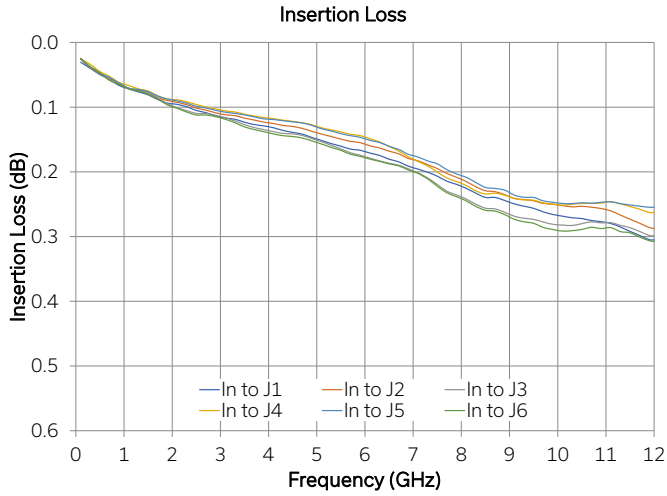



TTL

Mechanical Switch

ZK-MSP6TA-12

Mini-Circuits

50 Ω DC to 12 GHz SP6T SMA-Female

ABSOLUTE MAXIMUM RATINGS⁴

Parameter	Conditions	Limits	Units
Temperature	Operating	0 to +50	°C
	Storage	-20 to +60	
DC Voltage	Supply Voltage	+26	V
	Control Voltage	+5.5	
RF Input Power (No Damage)	Cold switching	20	W
	Hot switching	1	
	Into internal termination	1	

4. Permanent damage may occur if any of these limits are exceeded. Operating in the range between operating power limits and absolute maximum ratings for extended periods may result in reduced life and reliability.

DC ELECTRICAL SPECIFICATIONS

Parameter	Conditions	Typ	Units
Supply Voltage		24	V
Current Consumption	All ports disconnected	20	mA
	Any port active	120	

FUNCTIONAL BLOCK DIAGRAM

+24V GND TTL1 TTL2 TTL3 TTL4 TTL5 TTL6

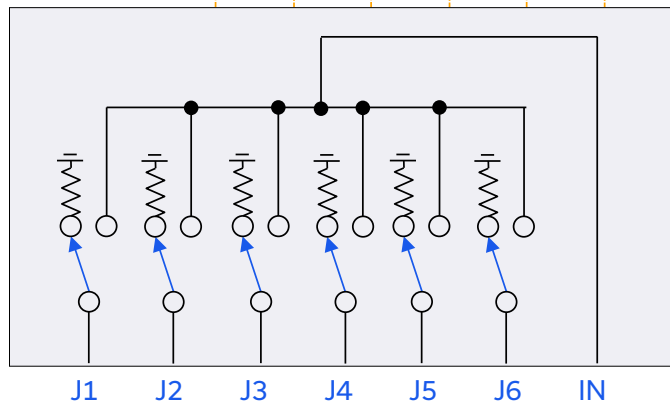
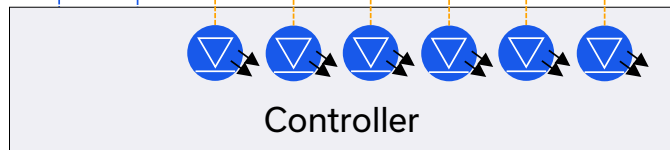

CONNECTIONS

Port	Connector
IN, J1-J6 ⁵	SMA female
DC & Control	Molex 53398-0871 (8-pin) ⁶
LED1-6	Bivar SMFLP series ⁷

5. IN = RF common port; J1-J6 = RF input / output ports

6. Mating connector is Molex 51021-0800

7. Compatible with Bivar SMFLP light pipe system (1mm diameter optical fiber)



TTL

Mechanical Switch

ZK-MSP6TA-12

Mini-Circuits

50 Ω DC to 12 GHz SP6T SMA-Female

CONTROL

ZK-MSP6TA-12 requires a single +24V DC voltage supply and ground connection, with 6 control inputs using TTL logic levels. Connect the included control cable assembly to the 8-pin header on the rear of ZK-MSP6TA-12. The other end of the cable assembly has exposed "pig-tail" wires which should be connected to the +24V DC supply and 6 TTL control sources.

The default switch state is "all ports disconnected" where the RF "In" port is open/reflective and ports J1 to J6 are internally terminated. The switch is always in this state when all 6 control inputs are at logic 0, or when no +24V DC supply is present.

To set the switch to any active state, apply the TTL logic level on the relevant control input only. Do not apply voltage to more than 1 TTL control input at a time.

Please contact testsolutions@minicircuits.com for support

SWITCH STATE TABLE

Switch State	TTL1	TTL2	TTL3	TTL4	TTL5	TTL6
All ports disconnected*	Low	Low	Low	Low	Low	Low
In to J1	High	Low	Low	Low	Low	Low
In to J2	Low	High	Low	Low	Low	Low
In to J3	Low	Low	High	Low	Low	Low
In to J4	Low	Low	Low	High	Low	Low
In to J5	Low	Low	Low	Low	High	Low
In to J6	Low	Low	Low	Low	Low	High

* In is open with ports J1-J6 internally terminated

CONTROL HARNESS (B66-0002-18)

8-Pin Connector Pin	Bare Wire Color	Function
1	Violet	TTL 6
2	Yellow	TTL 5
3	Green	TTL 4
4	Red	TTL 3
5	Blue	TTL 2
6	Orange	TTL 1
7	Brown	Ground
8	White	+24 V DC Supply

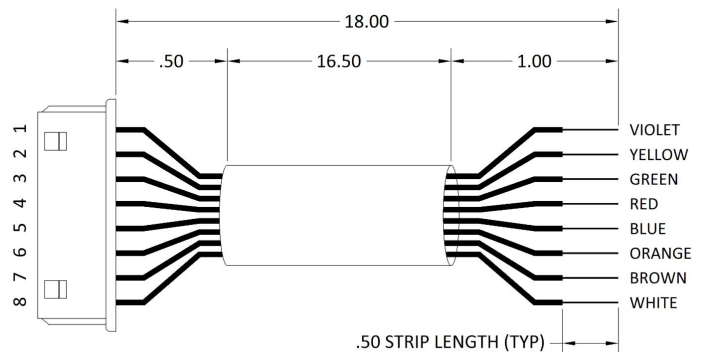



TTL

Mechanical Switch

ZK-MSP6TA-12

50 Ω DC to 12 GHz SP6T SMA-Female

CASE STYLE DRAWING

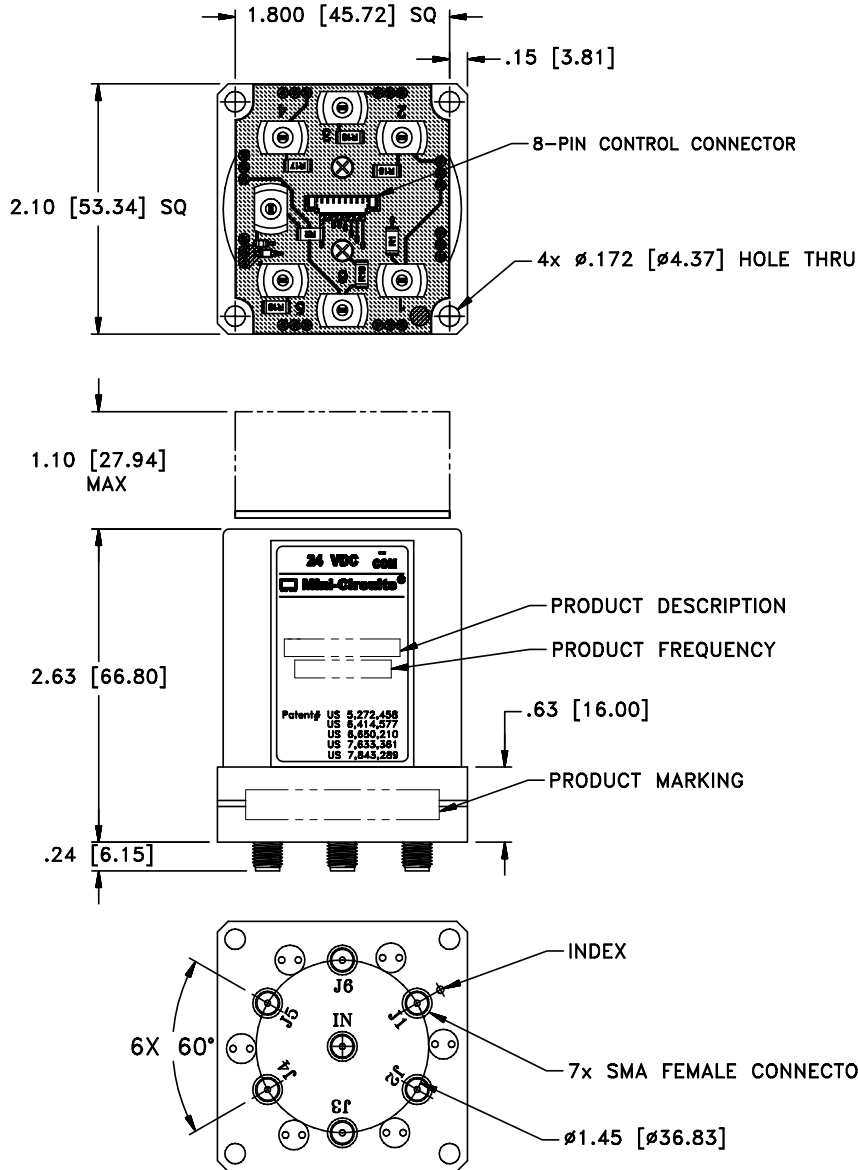

Weight: 260 grams.

Dimensions are in inches [mm]. Tolerances: 2 Pl. \pm .03; 3 Pl. \pm .015.

PRODUCT MARKING*

Product Marking: ZK-MSP6TA-12

Product Description: MSP6TA-12+ Absorptive switch

Product Frequency: DC - 12 GHz

*Marking may contain other features or characters for internal lot control





DETAILED MODEL INFORMATION IS AVAILABLE ON OUR WEBSITE [CLICK HERE](#)

Case Style	HJ2964
Environmental Rating	ENV55
Regulatory Compliance	RoHS Compliant

Contact Us: testsolutions@minicircuits.com

Included Accessories	Part Number	Description
	B66-0002-18	Control cable assembly (18" length) – 8-pin header connector (Molex 51021-0800) to 8 x bare wires (each 28 AWG)

NOTES

- A. Performance and quality attributes and conditions not expressly stated in this specification document are intended to be excluded and do not form a part of this specification document.
- B. Electrical specifications and performance data contained in this specification document are based on Mini-Circuit's applicable established test performance criteria and measurement instructions.
- C. The parts covered by this specification document are subject to Mini-Circuits standard limited warranty and terms and conditions (collectively, "Standard Terms"); Purchasers of this part are entitled to the rights and benefits contained therein. For a full statement of the standard. Terms and the exclusive rights and remedies thereunder, please visit Mini-Circuits' website at www.minicircuits.com/MCLStore/terms.jsp

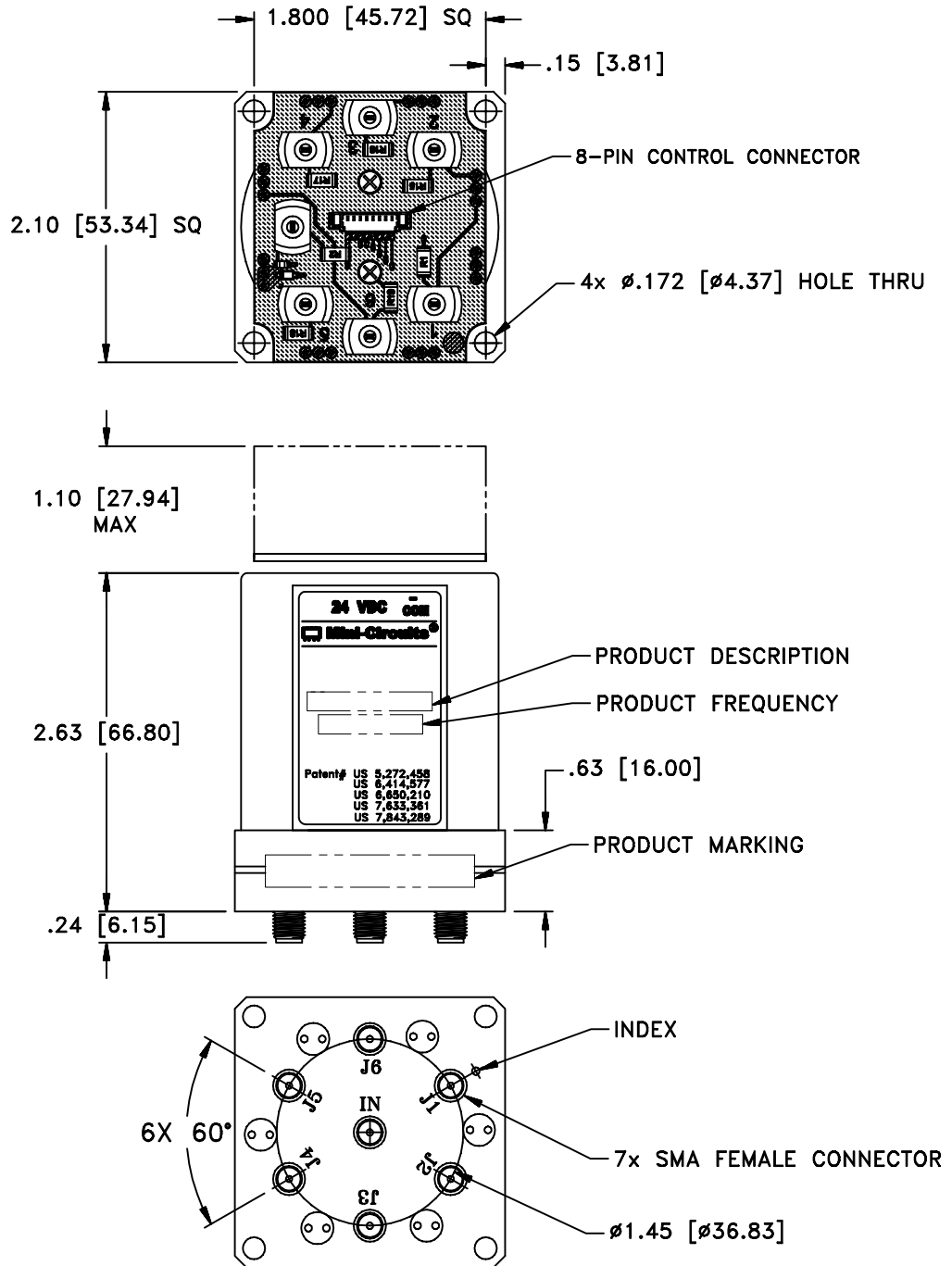

1. Case material: Copper-nickel alloy.
2. Dimensions are in inches (mm). Tolerances: 2 Pl. \pm .03; 3 Pl. \pm .015.
3. Weight: 260 grams.
4. Marking may contain other features or characters for internal lot control

Mini-Circuits
ISO 9001 ISO 14001 CERTIFIED

ALL NEW
minicircuits.com

P.O. Box 350166, Brooklyn, New York 11235-0003 (718) 934-4500 Fax (718) 332-4661 For detailed performance specs & shopping online see Mini-Circuits web site



The Design Engineers Search Engine Provides ACTUAL Data Instantly From MINI-CIRCUITS At: www.minicircuits.com

RF/IF MICROWAVE COMPONENTS



Environmental Specifications **ENV55**

All Mini-Circuits products are manufactured under exacting quality assurance and control standards, and are capable of meeting published specifications after being subjected to any or all of the following physical and environmental test.

Specification	Test/Inspection Condition	Reference/Spec
Operating Temperature	-0° to 50° C Ambient Environment	Individual Model Data Sheet
Storage Temperature	-20° to 60° C Ambient Environment	Individual Model Data Sheet
Operating and Storage Humidity	5% to 85% RH (non-condensing)	Ambient
Bench Handling Test	Bench Top Tip 45° & Drop	MIL-PRF-28800F
Transit Drop Test	Free Fall Drop, 20 cm (7.9 inches)	MIL-PRF-28800F Class 3