



COAXIAL

High Power Amplifier

ZHL-5W-202-S+ ZHL-5W-202X-S+

50Ω 5W 10 to 2000 MHz

THE BIG DEAL

- High Power, 5 Watt at saturation
- Class AB Amplifier
- Low Current consumption
- High IP3, +47 dBm typ.
- Usable from 5.0 MHz to 2200 MHz
- Good Gain Flatness, ±2.0 dB typ.
- No damage with an open or short output load while delivering up to 5W
- Shuts off when base plate temperature exceeds +85°C



Generic photo used for illustration purposes only

Model No.	ZHL-5W-202-S+	ZHL-5W-202X-S+▲
Case Style	BT1689-1	
Connectors	SMA	

+RoHS Compliant

The +Suffix identifies RoHS Compliance. See our website for methodologies and qualifications

APPLICATIONS

- Cellular
- PCN
- GSM
- ISM
- Lab Test

PRODUCT OVERVIEW

The ZHL-5W-202-S+ is a Class AB, high-power amplifier providing 5W saturated power over the 10 to 2000 MHz band, ideal for a variety of high-power test setups as well as applications including communications, radar and more. The ruggedly-designed amplifier provides unconditional stability and built-in self-protection against reverse polarity, excessive drive and overheating. The amplifier's output stage is further protected in the event of a fault condition, allowing high power operation into an OPEN or SHORT load (refer to the maximum input power specifications). Housed in a rugged aluminum alloy case measuring 4.3 x 6.7 x 1.2", the unit features SMA connectors and an optional heat sink and fan attachment for cooling.

KEY FEATURES

Feature	Advantages
Ultra Wideband, usable from 5.0 to 2200 MHz	Suitable for a broad range of high-power, wideband applications, including test setups, communications and defense applications.
High Gain, 50 dB	Enables signal amplification to 5W output without the need for multiple gain stages.
Built-in self-protection	In instances of potentially-damaging excessive drive current, heat buildup within the housing, unshorting of DC supply, and short or open loads at the output, an automatic sensing feature signals the unit to power down.
Unconditional stability	Provides reliable performance independent of input and load conditions.

REV. A
ECO-017723
ZHL-5W-202-S+
MCL NY
230502





COAXIAL

High Power Amplifier

ZHL-5W-202-S+ ZHL-5W-202X-S+

50Ω 5W 10 to 2000 MHz

ELECTRICAL SPECIFICATIONS AT 25°C

Parameter	Min.	Typ.	Max.	Units
Frequency Range	10		2000	MHz
Gain ¹	44	50	56	dB
Gain Flatness	—	±2.0	±2.7	dB
Output Power at 3dB compression	—	+38	—	dBm
Output Power at Saturation	+36	+40	—	dBm
Noise Figure	—	10	—	dB
Output third order intercept point	+39	+47	—	dBm
Input VSWR	—	1.2	—	:1
Output VSWR	—	2.0	—	:1
DC Supply Voltage	—	28	30	V
Supply Current ²	—	1.5	3.0	A

1. Small signal input power -50 dBm typ.

2. Power Supply should be capable of delivering 4A at start up.

▲ Heat sink and fan not included. Alternative heat sinking and heat removal must be provided by the user to limit maximum base-plate temperature to 85°C, in order to ensure proper performance. For reference, this requires thermal resistance of user's external heat sink to be 1.0°C/W max.

ABSOLUTE MAXIMUM RATINGS³

Parameter	Ratings
Operating Temperature	-20 °C to +60 °C
Storage Temperature	-55 °C to +100 °C
Base Plate Temperature	+85 °C
Input RF Power (no damage)	+5 dBm ⁴
	-19 dBm ⁵

3. Specifications apply to CW signals only permanent damage may occur if any of these limits are exceeded.

4. Into 50 ohm load.

5. Into open or short load





COAXIAL

High Power Amplifier

ZHL-5W-202-S+
ZHL-5W-202X-S+

Mini-Circuits

50Ω 5W 10 to 2000 MHz

OUTLINE DRAWING FOR MODELS WITH HEATSINK

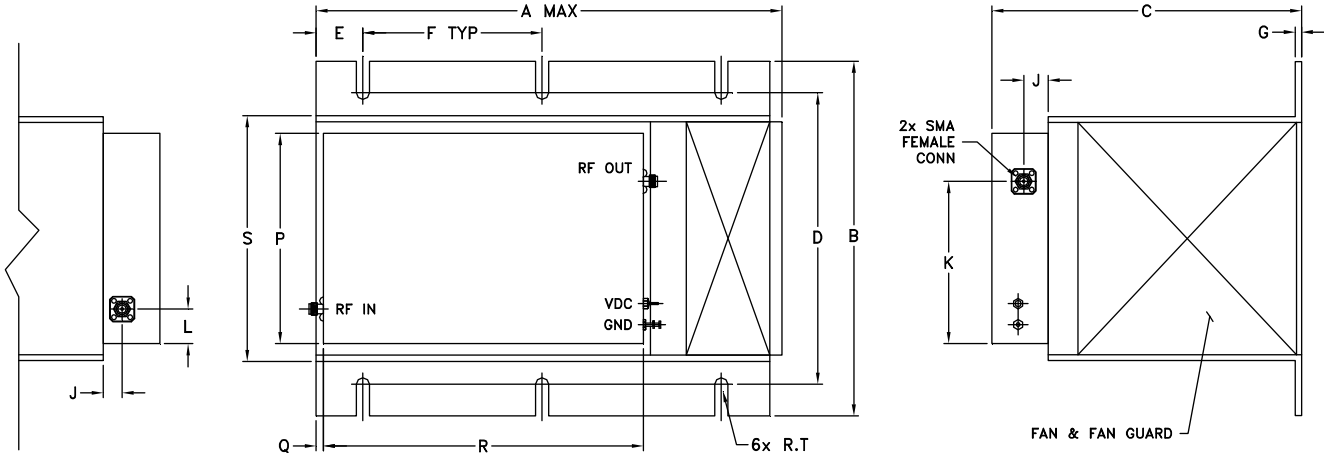

OUTLINE DRAWING FOR MODELS WITHOUT HEATSINK

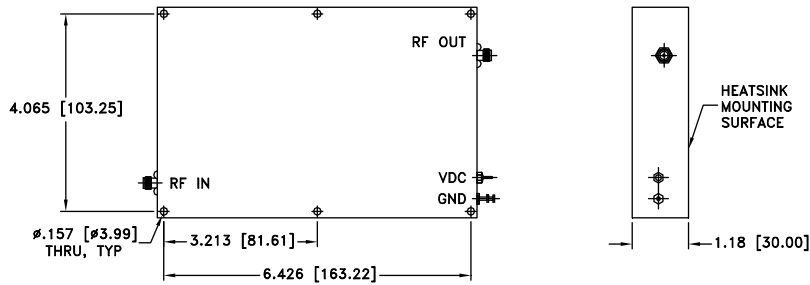

OUTLINE DIMENSIONS (Inch/mm)

A	B	C	D	E	F	G	J	K	L	M	P	Q	R	S	T	wt
9.85	7.30	6.50	6.00	0.98	3.75	0.13	0.47	3.34	0.71	--	4.33	0.20	6.69	5.10	0.14	grams*
250.19	185.42	167.64	152.4	24.89	95.25	3.30	12.00	84.80	18.00	--	110.00	5.08	170.00	129.54	3.45	4565
																*880 grams without heatsink





COAXIAL

High Power Amplifier

ZHL-5W-202-S+ ZHL-5W-202X-S+

Mini-Circuits

50Ω 5W 10 to 2000 MHz

TYPICAL PERFORMANCE DATA / GRAPHS

FREQUENCY (MHz)	GAIN (dB)	DIRECTIVITY (dB)	VSWR (:1)		NOISE FIGURE (dB)	POUT at 3 dB COMPR. (dBm)	POUT at SAT (dBm)	OUTPUT IP3 (dBm)
	28V	28V	IN	OUT	28V	28V	28V	28V
10	50.99	39.37	1.12	2.04	10.58	38.64	39.58	46.64
100	52.24	53.26	1.16	2.10	10.23	39.19	40.22	47.54
200	51.79	53.48	1.15	2.82	10.19	39.13	40.60	46.79
400	50.10	58.11	1.11	2.64	10.06	39.13	40.92	46.86
600	52.14	55.50	1.04	2.89	9.92	39.51	41.74	47.01
800	51.28	56.84	1.04	2.56	9.90	39.19	41.28	47.23
1000	50.66	66.82	1.05	2.10	9.99	38.86	41.93	47.80
1200	51.73	43.97	1.08	1.91	10.05	39.12	41.22	47.92
1400	51.85	44.97	1.05	1.76	10.01	38.70	41.22	48.27
1600	51.31	50.83	1.15	1.41	10.13	38.62	40.86	47.50
1800	50.82	52.86	1.10	1.26	10.12	38.58	40.86	46.89
2000	50.11	59.21	1.19	1.69	10.16	39.84	40.93	46.68

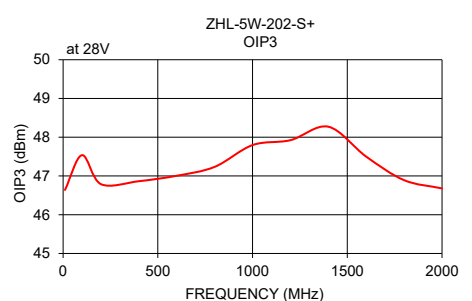
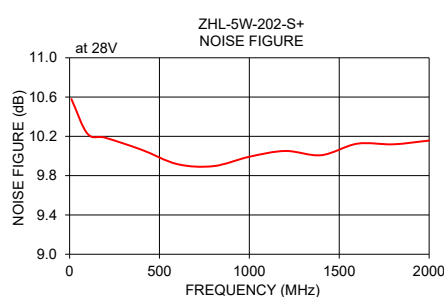
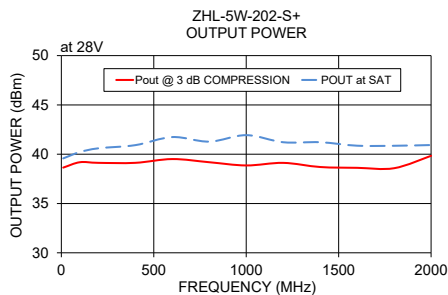
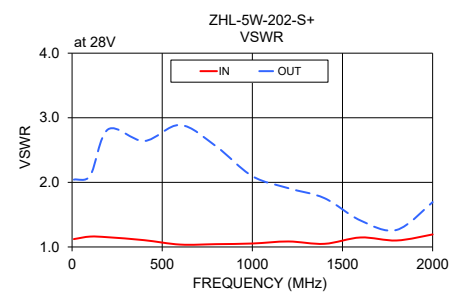
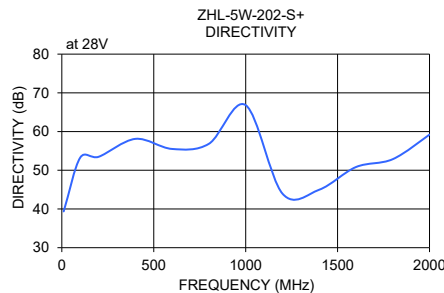
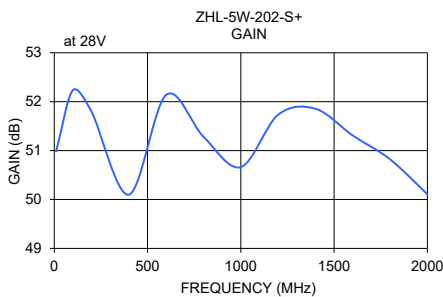

NOTES

- A. Performance and quality attributes and conditions not expressly stated in this specification document are intended to be excluded and do not form a part of this specification document.
- B. Electrical specifications and performance data contained in this specification document are based on Mini-Circuit's applicable established test performance criteria and measurement instructions.
- C. The parts covered by this specification document are subject to Mini-Circuits standard limited warranty and terms and conditions (collectively, "Standard Terms"); Purchasers of this part are entitled to the rights and benefits contained therein. For a full statement of the standard terms and the exclusive rights and remedies thereunder, please visit Mini-Circuits' website at www.minicircuits.com/terms/viewterm.html



High Power Amplifier

ZHL-5W-202-S+

Typical Performance Data

FREQUENCY (MHz)	GAIN (dB) 28V	DIRECTIVITY (dB) 28V	VSWR (:1)		NOISE FIGURE (dB) 28V	Pout @ 3 dB COMPRESSION	Pout @ SATURATION	OUTPUT IP3 (dBm) 28V
			IN 28V	OUT 28V		(dBm) 28V	(dBm) 28V	
5	49.2	38.5	1.12	2.22	--	38.91	40.02	45.98
6	49.8	34.0	1.13	2.18	--	38.82	39.85	46.31
7	50.2	31.0	1.13	2.10	--	38.73	39.74	46.55
8	50.5	30.8	1.13	2.09	--	38.68	39.66	46.65
9	50.8	35.3	1.12	2.08	--	38.65	39.61	46.67
10	51.0	39.4	1.12	2.04	10.58	38.64	39.58	46.64
15	51.6	59.4	1.12	1.95	10.58	38.68	39.56	47.34
20	51.9	33.1	1.13	1.91	10.36	38.77	39.60	47.62
25	52.1	46.4	1.13	1.86	10.36	38.78	39.62	47.75
30	52.2	35.6	1.14	1.81	10.32	38.79	39.64	47.87
35	52.2	30.0	1.14	1.79	10.32	38.82	39.72	48.06
40	52.3	34.6	1.14	1.77	10.27	38.88	39.82	48.12
45	52.3	39.8	1.14	1.74	10.27	38.98	39.91	48.29
50	52.3	42.2	1.15	1.75	10.26	39.06	40.00	48.46
55	52.2	46.9	1.15	1.73	10.26	39.13	40.07	48.38
60	52.2	52.2	1.15	1.75	10.25	39.17	40.12	48.46
65	52.2	47.6	1.16	1.78	10.25	39.18	40.14	48.46
70	52.2	43.5	1.16	1.80	10.25	39.18	40.14	48.47
75	52.2	51.5	1.16	1.84	10.25	39.16	40.14	48.33
80	52.2	55.9	1.16	1.89	10.24	39.17	40.13	48.51
85	52.3	42.0	1.16	1.96	10.24	39.15	40.13	47.77
90	52.3	45.4	1.16	2.00	10.23	39.18	40.15	47.72
95	52.3	51.4	1.16	2.05	10.23	39.19	40.20	47.68
100	52.2	53.3	1.16	2.10	10.23	39.19	40.22	47.54
150	52.1	43.4	1.15	2.44	10.22	39.09	40.22	46.84
200	51.8	53.5	1.15	2.82	10.19	39.13	40.60	46.79
250	51.2	54.3	1.14	2.85	10.15	39.02	40.26	46.37
300	50.5	50.1	1.13	2.86	10.13	39.28	40.77	46.75
350	50.2	45.4	1.12	2.71	10.08	38.67	40.20	46.12
400	50.1	58.1	1.11	2.64	10.06	39.13	40.92	46.86
450	50.3	47.0	1.09	2.71	10.02	38.73	40.87	46.45
500	50.9	56.4	1.07	2.79	9.98	39.46	41.35	47.00
550	51.6	43.3	1.05	2.86	9.94	38.71	40.97	46.17
600	52.1	55.5	1.04	2.89	9.92	39.51	41.74	47.01
650	52.4	58.8	1.04	2.83	9.91	39.13	41.24	46.84
700	52.2	49.4	1.04	2.71	9.90	39.41	41.09	46.60
750	51.8	39.6	1.04	2.66	9.88	38.37	40.89	46.21
800	51.3	56.8	1.04	2.56	9.90	39.19	41.28	47.23
850	50.8	52.3	1.05	2.50	9.93	39.01	41.48	47.30
900	50.5	57.5	1.05	2.33	9.96	39.47	41.55	47.29
950	50.4	66.5	1.05	2.26	10.00	38.54	41.64	47.24
1000	50.7	66.8	1.05	2.10	9.99	38.86	41.93	47.80
1050	51.2	44.3	1.05	2.07	9.98	38.29	41.10	47.88
1100	51.7	42.9	1.07	2.01	9.95	38.39	41.22	47.59
1150	51.9	43.7	1.08	2.01	9.99	38.68	41.57	48.23
1200	51.7	44.0	1.08	1.91	10.05	39.12	41.22	47.92
1250	51.5	42.6	1.08	1.92	10.09	39.50	41.46	48.33
1300	51.4	52.0	1.07	1.85	10.06	39.59	41.38	48.23
1350	51.6	44.4	1.05	1.84	10.03	39.47	41.41	48.23
1400	51.9	45.0	1.05	1.76	10.01	38.70	41.22	48.27
1450	52.1	43.9	1.07	1.70	10.02	38.98	41.35	48.29
1500	52.1	45.3	1.10	1.60	10.07	38.81	41.11	47.90
1550	51.8	51.6	1.13	1.48	10.11	38.97	41.04	47.34
1600	51.3	50.8	1.15	1.41	10.13	38.62	40.86	47.50
1650	50.7	50.5	1.15	1.31	10.12	38.56	40.99	46.69
1700	50.4	47.6	1.14	1.27	10.12	38.35	40.76	46.65
1750	50.3	45.8	1.13	1.23	10.11	38.43	40.70	46.58
1800	50.8	52.9	1.10	1.26	10.12	38.58	40.86	46.89
1850	51.5	67.4	1.09	1.27	10.14	38.77	40.92	46.89
1900	52.0	47.3	1.14	1.41	10.17	39.53	41.18	47.27
1950	51.4	48.5	1.18	1.49	10.17	39.79	40.99	46.89
2000	50.1	59.2	1.19	1.69	10.16	39.84	40.93	46.68
2050	48.7	47.5	1.16	1.64	10.20	39.97	41.16	47.07
2100	47.6	53.4	1.13	1.96	10.25	39.90	40.98	46.20
2150	46.9	48.3	1.10	1.91	10.30	39.21	40.34	45.66
2200	46.2	57.4	1.08	2.38	10.35	38.14	39.27	45.07



P.O. Box 350166, Brooklyn, New York 11235-0003 • (718) 934-4500 • Fax (718) 332-4661 For detailed performance specs & shopping online see Mini-Circuits web site
 The Design Engineers Search Engine Provides ACTUAL Data Instantly From MINI-CIRCUITS At: www.minicircuits.com



IF/RF MICROWAVE COMPONENTS

Typical Performance Curves

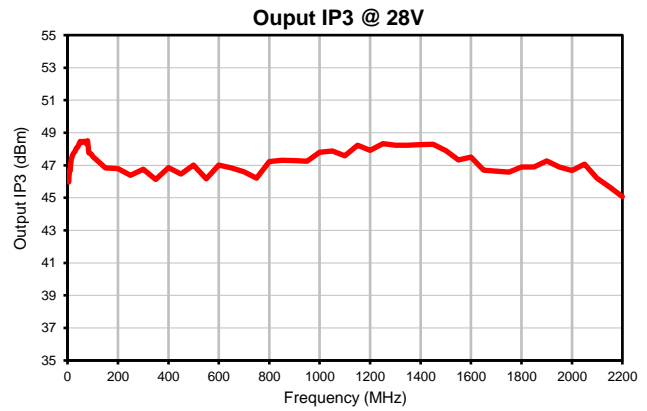
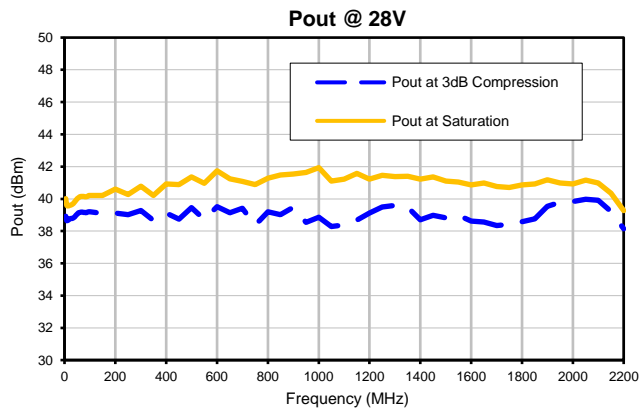
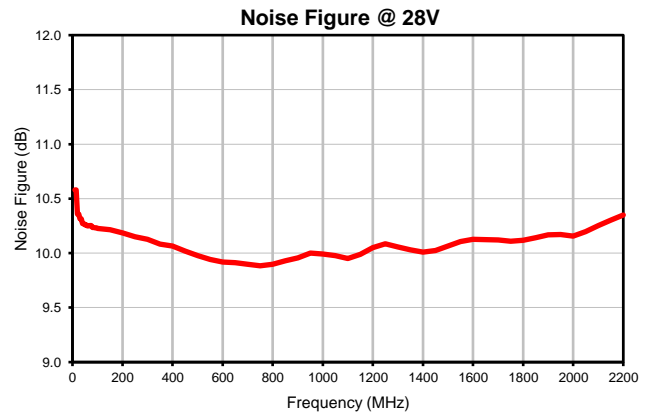
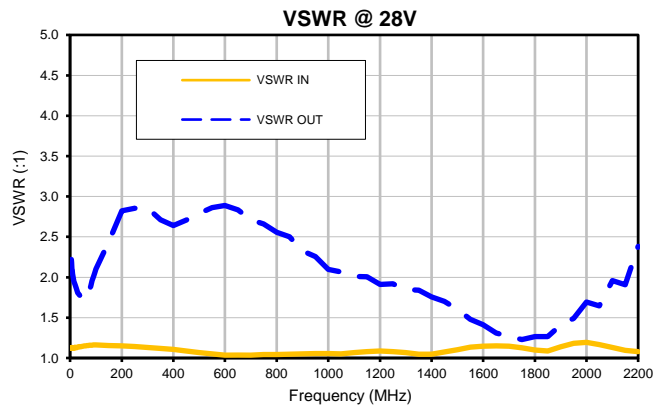
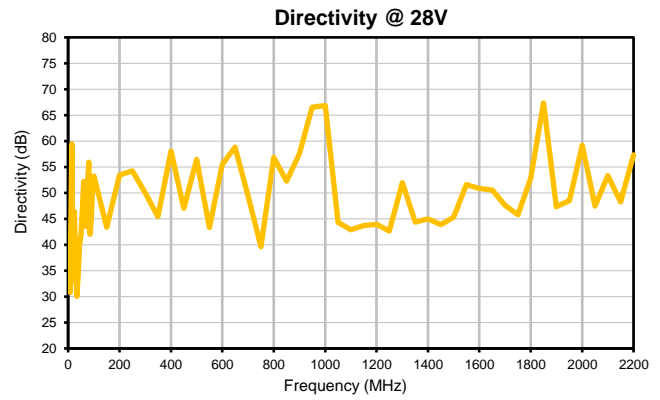
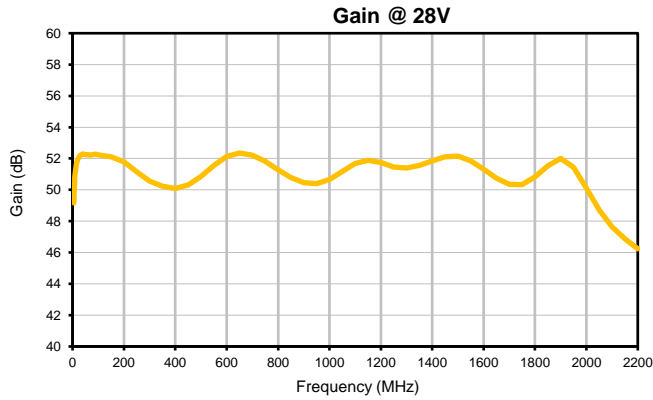

Outline Dimensions

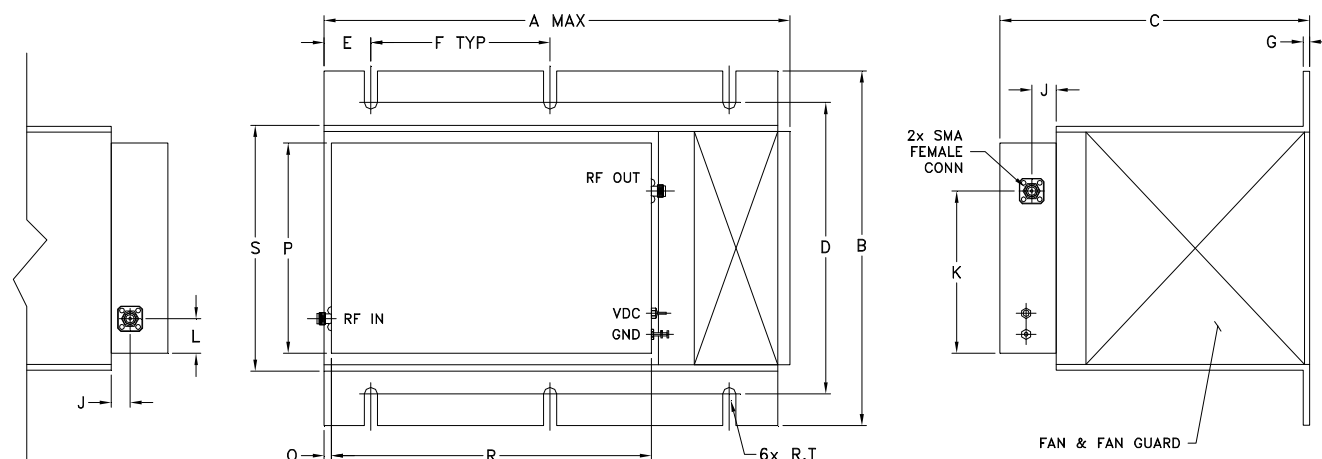

MOUNTING INFORMATION FOR MODELS WITHOUT HEATSINK

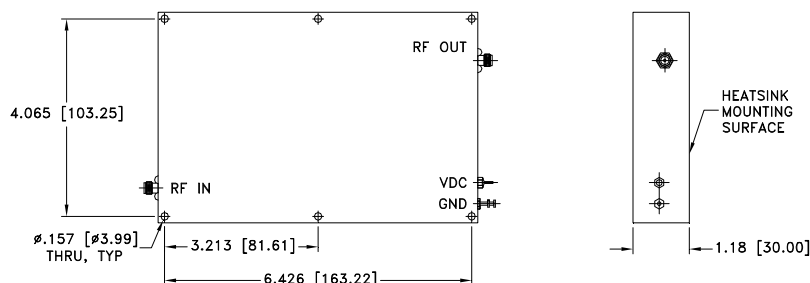

CASE#	A	B	C	D	E	F	G	H	J	K	L	M	N
BT1689-1	9.85 (250.19)	7.3 (185.42)	6.5 (165.10)	6.00 (152.40)	.98 (24.89)	3.75 (95.25)	.13 (3.30)	- -	.47 (12.0)	3.34 (84.8)	.71 (18.0)	- -	- -

CASE#	P	Q	R	S	T	WT, GRAM	WT WITHOUT HEATSINK, GRAM
BT1689-1	4.33 (110.00)	.2 (5.08)	6.69 (170.00)	5.1 (129.54)	.136 (3.45)	4565	880

Dimensions in inches (mm). Tolerances: 1 Pl. $\pm .1$; 2Pl. $\pm .03$; 3 Pl. $\pm .015$

Notes:

- Case material: Aluminum alloy.
- Finish:
For RoHS Case Styles: Clear Chemical conversion coating, non-chrome or trivalent chrome based.
- Heatsink finish: Black anodize.
- Refer to the individual model data sheet for the type of connectors available.
- Recommended screws for mounting model without heat sink on 3/32" thick sheet: #6-32, 1.50" Length.
- Shape of connector flange may vary.



P.O. Box 350166, Brooklyn, New York 11235-0003 (718) 934-4500 Fax (718) 332-4661 For detailed performance specs & shopping online see Mini-Circuits web site



The Design Engineers Search Engine Provides ACTUAL Data Instantly From MINI-CIRCUITS At: www.minicircuits.com

RF/IF MICROWAVE COMPONENTS



All Mini-Circuits products are manufactured under exacting quality assurance and control standards, and are capable of meeting published specifications after being subjected to any or all of the following physical and environmental test.

Specification	Test/Inspection Condition	Reference/Spec
Operating Temperature	-20° to 45°C Ambient Environment	Individual Model Data Sheet
Storage Temperature	-55° to 100° C Ambient Environment	Individual Model Data Sheet
Stabilization Bake	(non-operating) 125°C, 24 hours	- - -
Burn-in at Elevated Temp.	(DC on) 160 hours at 60° C base plate Temperature	MIL-STD-202, Method 108
Thermal Shock	-55° to 100°C, 5 cycles	MIL-STD-202, Method 107, Condition A, except 100°C