



COAXIAL

High Power Amplifier

ZHL-50W-GAN+ ZHL-50W-GANX+

50Ω 20 to 500 MHz Broadband 50W SMA-Female

THE BIG DEAL

- High Output Power, 50W
- High Output IP2, +80dBm typ.
- High Output IP3, +55dBm typ.
- Reverse Polarity Protected
- Unconditionally stable
- Protected by US patent 7,348,854



With heatsink



Without heatsink

Generic photo used for illustration purposes only

APPLICATIONS

- Broad based test laboratory amplifier
- Test setup driver amplifier
- VHF test amplifier
- Amplifier for burn-in test setups

FUNCTIONAL DIAGRAM

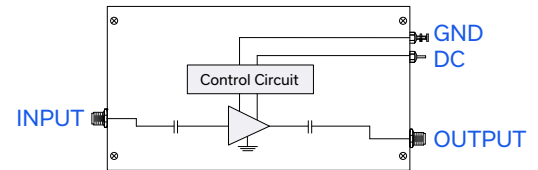

PRODUCT OVERVIEW

The ZHL-50W-GAN+ and ZHL-50W-GANX+ are Class A, high power amplifiers that utilize a Gallium Nitride (GaN) push-pull output stage, which results in a higher efficiency (50% typ.) as compared to GaAs, LDMOS and VDMOS counterparts. These amplifiers provide 50 W (typical) of output power at 1dB Compression Point from 20 MHz to 500 MHz and are well suited for a variety of high-power test setups as well as communication applications. They are ruggedly designed and provide unconditional stability and built-in self-protection against over and reverse voltage and over temperature conditions. The GaN Transistors boast a maximum junction temperature up to +250 °C translating into the higher MTBF and improved reliability.

KEY FEATURES

Features	Advantages
High Efficiency	Higher PAE results in significant cost savings over the operating life of the amplifier.
Rugged Design	Extreme load mismatch such as open/short at the RF output are tolerated without damaging the amplifier. At constant open/short and +28V nominal supply voltage.
Range of Protections	Over temperature, over voltage and reverse polarity protection add to the ruggedness of the amplifier.



COAXIAL

High Power Amplifier

ZHL-50W-GAN+ ZHL-50W-GANX+

50Ω 20 to 500 MHz Broadband 50W SMA-Female

ELECTRICAL SPECIFICATIONS AT $T_{BASEPLATE} = +25^{\circ}\text{C}$, $V_{DC} = +28\text{V}$

Parameter	Condition	Min.	Typ.	Max.	Units
Frequency Range		20		500	MHz
Small Signal Gain	$P_{IN} = -40\text{ dBm}$	40	43.5	47	dB
Small Signal Gain Flatness	$P_{IN} = -40\text{ dBm}$		± 1.2	± 2.7	dB
Output Power at 1dB compression, reference level $P_{IN} = -10\text{ dBm}$	20-100 MHz	+46.2	+47		dBm
	100-500 MHz	+46.8	+48		dBm
Output Power at 3dB compression, reference level $P_{IN} = -10\text{ dBm}$	20-100 MHz		+48		dBm
	100-500 MHz		+49		dBm
Noise Figure			7	12	dB
Output Third Order Intercept Point			+55		dBm
Output Second Order Intercept Point			+80		dBm
Input VSWR			1.7		:1
Output VSWR			2.6		:1
DC Supply Voltage			+28	+31	V
DC Supply Current for ZHL-50W-GAN+ (with heatsink/fan) ¹			7.2	7.4	A

1. DC Power Supply should be able to deliver 13A DC at startup.



COAXIAL

High Power Amplifier

ZHL-50W-GAN+ ZHL-50W-GANX+

Mini-Circuits

50Ω 20 to 500 MHz Broadband 50W SMA-Female

TYPICAL PERFORMANCE GRAPHS @+25C

SMALL SIGNAL GAIN AT +28V

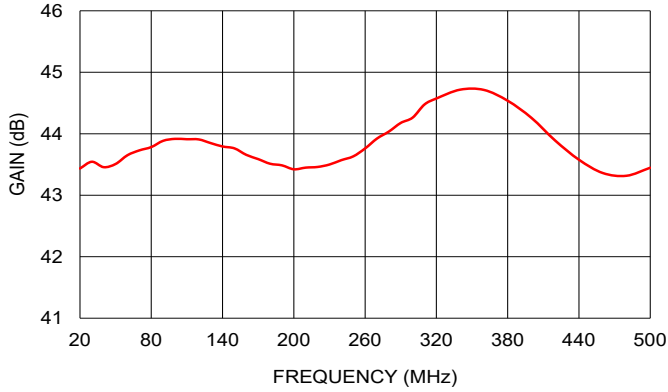

INPUT VSWR AT +28V

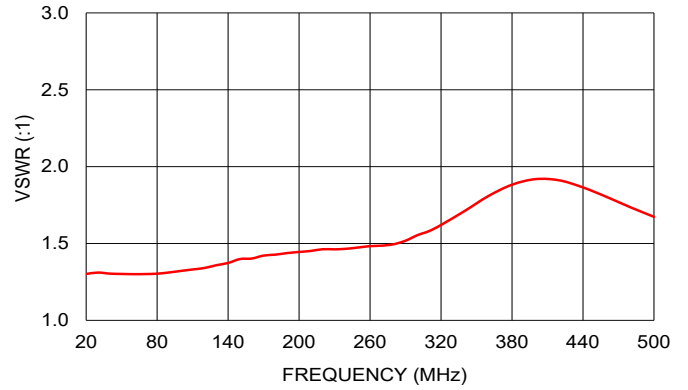

OUTPUT VSWR AT +28V

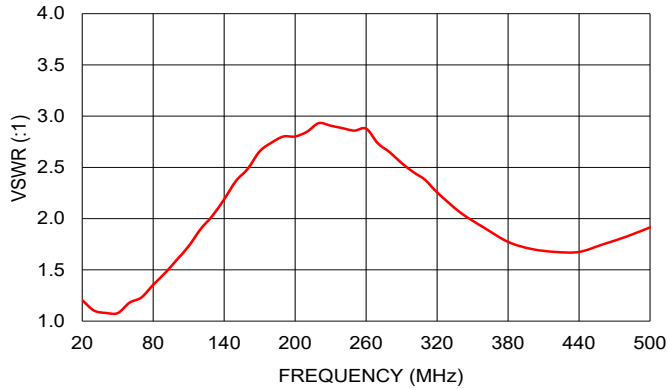

P1dB AT +28V

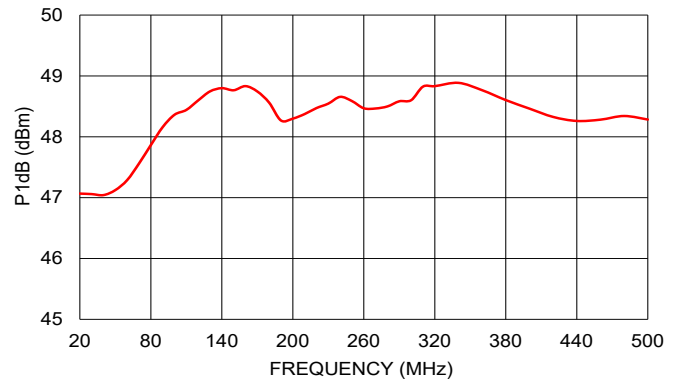

P3dB AT+ 28V

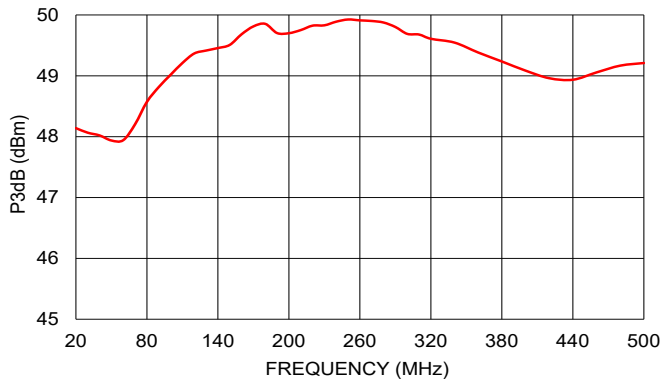

NOISE FIGURE AT +28V

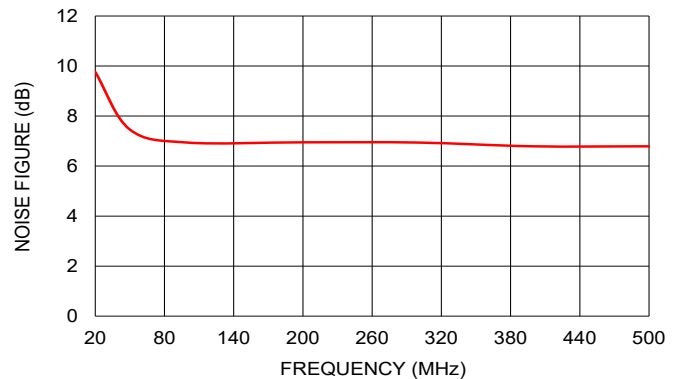



COAXIAL

High Power Amplifier

ZHL-50W-GAN+ ZHL-50W-GANX+

Mini-Circuits

50Ω 20 to 500 MHz Broadband 50W SMA-Female

ABSOLUTE MAXIMUM RATINGS²

Parameter	Ratings	
Operating Temperature	ZHL-50W-GAN+	T _{AIR AMBIENT} : -25 °C to +65 °C
	ZHL-50W-GANX+	T _{BASEPLATE} : -25 °C to +85 °C
Storage Temperature	-55 °C to +100 °C	
RF Input Power (no damage)	+13 dBm	
DC Operating Voltage	+31 V	

2. Permanent damage may occur if any of these limits are exceeded.

DETERMINING MAXIMUM THERMAL RESISTANCE OF USERS' EXTERNAL HEAT SINK

<i>MAXIMUM THERMAL RESISTANCE</i>	$= \frac{\text{MAXIMUM OPERATING CASE TEMP} - \text{MAXIMUM USER AMBIENT TEMP}}{\text{POWER DISSIPATION}}$
Example:	<p>MAXIMUM MOUNTING BASE TEMP = +85 °C (CHECK MAXIMUM RATINGS TABLE FOR THIS VALUE)</p> <p>MAXIMUM USER AMBIENT TEMP = +65 °C (USER DEFINED)</p> <p>POWER DISSIPATION = 7.1A*28V=199 WATTS</p> <p>THEN MAXIMUM ALLOWABLE THERMAL RESISTANCE = (85 °C - 65 °C)/199W = 0.1 °C/W</p>



COAXIAL

High Power Amplifier

ZHL-50W-GAN+ ZHL-50W-GANX+

50Ω 20 to 500 MHz Broadband 50W SMA-Female

CASE STYLE DRAWING WITH HEATSINK AND FAN (ZHL-50W-GAN+)

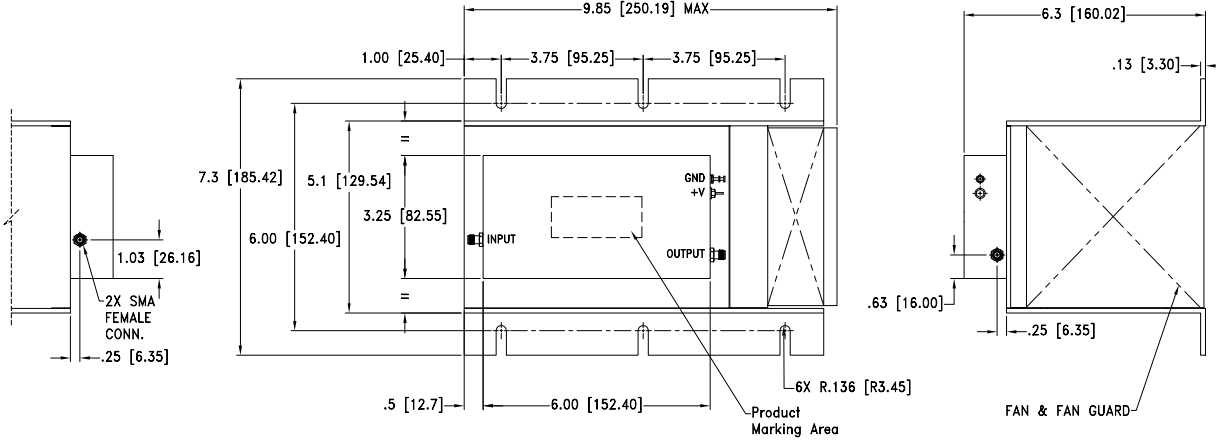

PRODUCT MARKING*: ZHL-50W-GAN+

CASE STYLE DRAWING WITHOUT HEATSINK AND FAN (ZHL-50W-GANX+)

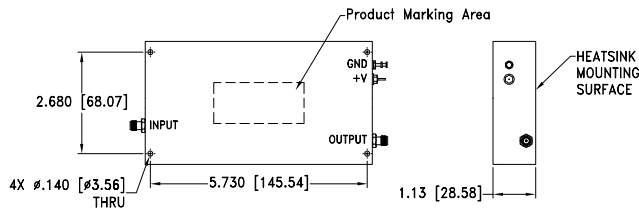

Weight With Heatsink: 4185 grams; Without Heatsink: 500 grams
Dimensions are in inches [mm]. Tolerances: 1 Pl.±0.1; 2 Pl.±0.03; 3Pl.±0.015 Inch

PRODUCT MARKING*: ZHL-50W-GANX+

*Marking may contain other features or characters for internal lot control.



COAXIAL

High Power Amplifier

ZHL-50W-GAN+ ZHL-50W-GANX+

50Ω 20 to 500 MHz Broadband 50W SMA-Female

ADDITIONAL INFORMATION IS AVAILABLE ON OUR DASHBOARD.

Performance Data	Electrical Specifications
	Graphs
	S-Parameters (S2P Files)
RoHs Status	Compliant
Environmental Ratings	ENV23T3

ORDERING INFORMATION

Model No. Links	ZHL-50W-GAN+	ZHL-50W-GANX+
Option	With heatsink & fan	Without heatsink & fan
Case Style	BT1165	
Connector	IN (SMA-Female) / OUT (SMA-Female)	

NOTES

- A. Performance and quality attributes and conditions not expressly stated in this specification document are intended to be excluded and do not form a part of this specification document.
- B. Electrical specifications and performance data contained in this specification document are based on Mini-Circuit's applicable established test performance criteria and measurement instructions.
- C. The parts covered by this specification document are subject to Mini-Circuits standard limited warranty and terms and conditions (collectively, "Standard Terms"); Purchasers of this part are entitled to the rights and benefits contained therein. For a full statement of the standard terms and the exclusive rights and remedies thereunder, please visit Mini-Circuits' website at www.minicircuits.com/terms/viewterm.html



Typical Performance Data

FREQUENCY (MHz)	GAIN (dB) 28V	ISOLATION (dB) 28V	VSWR (:1)		P _{OUT} @ 1 dB COMPRESSION (dBm) 28V	P _{OUT} @ 3 dB COMPRESSION (dBm) 28V	P _{OUT} at SATURATION (dBm) 28V
			IN 28V	OUT 28V			
20	43.44	65.74	1.30	1.20	47.07	48.14	48.63
30	43.54	68.42	1.31	1.10	47.06	48.07	48.61
40	43.46	73.92	1.30	1.08	47.04	48.02	48.55
50	43.51	73.17	1.30	1.08	47.12	47.94	48.54
60	43.65	73.04	1.30	1.18	47.29	47.94	48.52
70	43.73	71.07	1.30	1.23	47.56	48.20	48.71
80	43.78	73.45	1.30	1.35	47.86	48.57	48.98
90	43.89	83.02	1.31	1.47	48.16	48.81	49.20
100	43.92	81.12	1.32	1.60	48.36	49.02	49.34
110	43.91	79.31	1.33	1.73	48.44	49.21	49.47
120	43.91	69.42	1.34	1.90	48.60	49.37	49.55
130	43.85	74.07	1.36	2.03	48.75	49.41	49.60
140	43.79	80.32	1.37	2.19	48.80	49.46	49.62
150	43.76	66.54	1.40	2.37	48.76	49.51	49.62
160	43.66	79.39	1.40	2.49	48.83	49.68	49.76
170	43.59	74.52	1.42	2.66	48.74	49.81	49.86
180	43.51	74.01	1.43	2.74	48.56	49.85	49.90
190	43.49	73.68	1.44	2.80	48.27	49.70	49.78
200	43.42	76.71	1.44	2.80	48.30	49.70	49.76
210	43.45	77.98	1.45	2.85	48.37	49.75	49.80
220	43.46	70.28	1.46	2.93	48.47	49.82	49.87
230	43.50	76.51	1.46	2.91	48.54	49.83	49.91
240	43.57	76.42	1.47	2.88	48.66	49.89	49.97
250	43.63	82.51	1.47	2.86	48.59	49.93	50.00
260	43.76	80.91	1.48	2.88	48.47	49.91	50.01
270	43.92	76.89	1.49	2.73	48.46	49.90	50.00
280	44.04	73.56	1.50	2.65	48.50	49.88	49.98
290	44.18	83.08	1.52	2.54	48.58	49.80	49.93
300	44.26	64.92	1.55	2.45	48.60	49.69	49.85
310	44.48	72.66	1.58	2.38	48.82	49.68	49.85
320	44.57	78.08	1.62	2.26	48.83	49.61	49.79
340	44.72	72.62	1.71	2.06	48.89	49.55	49.78
360	44.71	88.90	1.81	1.91	48.77	49.38	49.62
380	44.54	74.52	1.88	1.77	48.60	49.24	49.48
400	44.26	71.23	1.92	1.70	48.46	49.09	49.32
420	43.89	77.35	1.91	1.68	48.33	48.96	49.20
440	43.58	80.62	1.86	1.68	48.26	48.94	49.16
460	43.36	70.37	1.80	1.75	48.28	49.06	49.26
480	43.32	73.04	1.74	1.82	48.34	49.17	49.39
500	43.45	73.12	1.67	1.91	48.28	49.21	49.45

Typical Performance Curves

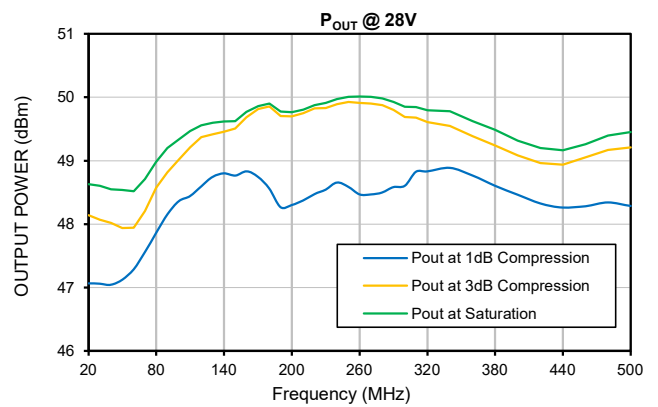
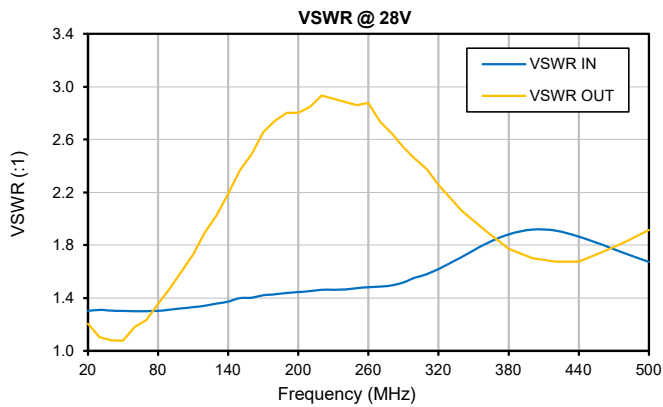
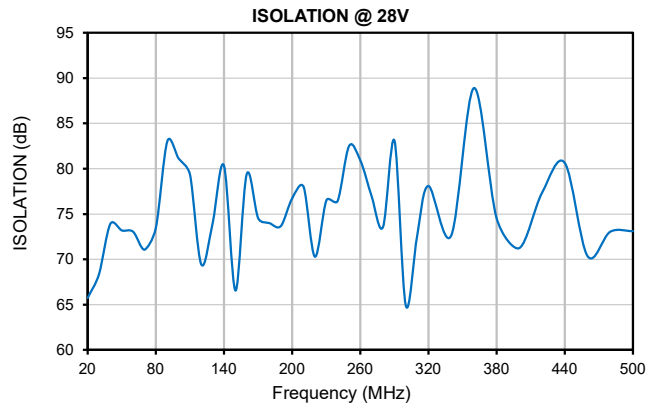
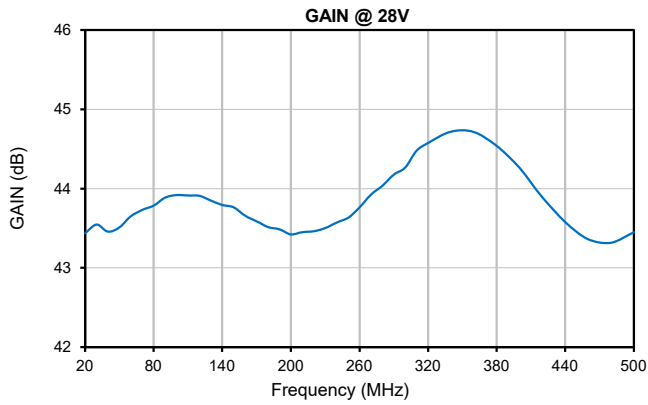

Outline Dimensions

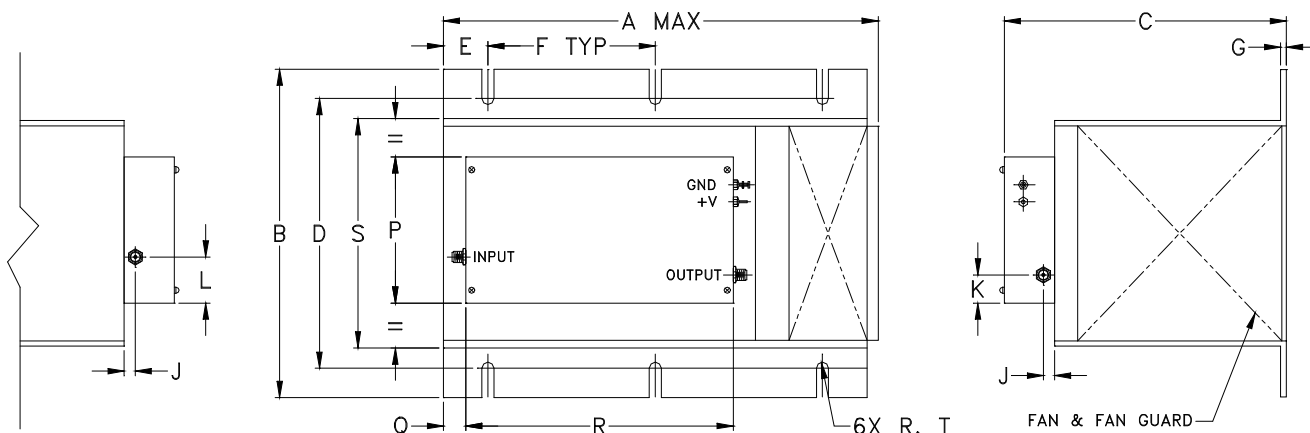

MOUNTING INFORMATION FOR MODELS WITHOUT HEATSINK.

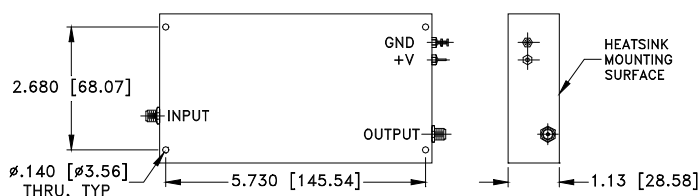

CASE#	A	B	C	D	E	F	G	H	J	K	L	M	N
BT1165	9.85 (250.19)	7.3 (185.42)	6.3 (160.02)	6.00 (152.40)	1.00 (25.40)	3.75 (95.25)	.13 (3.30)	-	.25 (6.35)	.63 (16.00)	1.03 (26.16)	-	-

CASE#	P	Q	R	S	T	WT, GRAM	WT WITHOUT HEATSINK, GRAM
BT1165	3.25 (82.55)	.5 (12.70)	6.00 (152.40)	5.1 (129.54)	.135 (3.43)	4185	500

Dimensions are in inches (mm). Tolerances: 1 Pl. $\pm .1$; 2 Pl. $\pm .03$; 3 Pl. $\pm .015$

Notes:

- Case material: Aluminum alloy.
- Finish:
 - For RoHS Case Styles: Clear Chemical conversion coating, non-chrome or trivalent chrome based.
 - For non RoHS Case Styles: Yellow Chromate with low electrical Resistance.
- Heatsink finish: Black anodize.
- Refer to the individual model data sheet for the type of connectors available.
- Recommended screws for mounting model without heat sink on 3/32" thick sheet: #6-32, 1.50" Length.



P.O. Box 350166, Brooklyn, New York 11235-0003 (718) 934-4500 Fax (718) 332-4661 For detailed performance specs & shopping online see Mini-Circuits web site



The Design Engineers Search Engine Provides ACTUAL Data Instantly From MINI-CIRCUITS At: www.minicircuits.com

RF/IF MICROWAVE COMPONENTS



All Mini-Circuits products are manufactured under exacting quality assurance and control standards, and are capable of meeting published specifications after being subjected to any or all of the following physical and environmental test.

Specification	Test/Inspection Condition	Reference/Spec
Operating Temperature	-20° to 65° C Ambient Environment	Individual Model Data Sheet
Storage Temperature	-55° to 100° C Ambient Environment	Individual Model Data Sheet
Stabilization Bake	(non-operating) 125°C, 24 hours	- - -
Burn-in at Elevated Temp.	(DC on) 160 hours at 85° C	MIL-STD-202, Method 108
Thermal Shock	-55° to 100°C, 5 cycles	MIL-STD-202, Method 107, Condition A, except 100°C