



COAXIAL

High Power Amplifier

ZHL-30W-262-S+ ZHL-30W-262X-S+

50Ω 30W 2300 to 2550 MHz

THE BIG DEAL

- High Power, 30 Watt
- Low Current consumption, 3.2A typ.
- Usable over 2200 to 2600 MHz
- Good Gain Flatness, ±1.5 dB typ.
- Excellent VSWR, 1.25:1 typ.
- No damage with an open or short output load under full CW output power
- Shuts off when base plate temperature exceeds +80°C
- Accepts wide range of DC supply voltage +25 to +29V



Generic photo used for illustration purposes only

Model No.	ZHL-30W-262-S+	ZHL-30W-262X-S+ [▲]
Case Style	BT1344	
Connectors	SMA / D-Sub Male	

APPLICATIONS

- WiFi
- Lab test

PRODUCT OVERVIEW

ZHL-30W-262-S+ is a ruggedized High Power Amplifier delivering 30W signals covering the 2400 MHz ISM, WLAN and S-Band radar bands. This amplifier supports a variety of applications from communication, radar to critical test and measurement systems and includes over-temperature self-protect and alarming circuits as well as internal protection circuits to prevent damage due to operation into an open or short under full RF power.

KEY FEATURES

Feature	Advantages
Good Gain Flatness, ±1.5 dB	Predictable performance and signal level strength
Excellent Input and Output VSWR, 1.25:1	Well-matched for full power transmission
Over temperature shut down	The ZHL-30W-262+ includes internal temperature monitoring circuits to automatically shut down the amplifier in the event of over temperature operation. Set for approximately +85°C shutdown (with auto recovery at 70°C), this feature ensures that users whom have difficulty in controlling their thermal environment or need to operate in a remote mode and cannot monitor the amplifier real time, can function with the security that a thermal run-away condition will be avoided through this self management feature. Furthermore, the ZHL-30W-262+ provides a TTL output to indicate thermal shutdown for remote automated systems.
Output load protection	A high root cause for damage to power amplifiers is the operation into highly reflective loads. The ZHL-30W-262+ power amplifier includes circuits to enable the amplifier to operate without damage in the presence of an open or short over all phases.
Excellent Output Power: 30W	Providing 30W of output power at the WiFi bands, this amplifier is an ideal lab test amplifier operating over the entire 2.3 to 2.5 GHz band.

REV. D
ECO-017583
ZHL-30W-262+
MCL NY
230424





COAXIAL

High Power Amplifier

ZHL-30W-262-S+ ZHL-30W-262X-S+

50Ω 30W 2300 to 2550 MHz

ELECTRICAL SPECIFICATIONS

Parameter	Condition (MHz)	ZHL-30W-262-S+			ZHL-30W-262X-S+ [▲]			Units
		Min.	Typ.	Max.	Min	Typ.	Max.	
Frequency Range		2300	–	2550	2300	–	2550	MHz
Gain	2300-2550	42	50	55	42	50	55	dB
	2400-2500	43	50	55	43	50	55	
Gain Flatness	2300-2550	–	–	±3.5	–	–	±3.5	dB
	2400-2500	–	–	±1.2	–	–	±1.2	
Output Power at 1dB compression	2300-2550	+41	+43	–	+41	+43	–	dBm
	2400-2500	+42	+43	–	+42	+43	–	
Saturated Output Power at 3dB compression	2300-2550	+43	+45	–	+43	+45	–	dBm
	2400-2500	+44	+45	–	+44	+45	–	
Noise Figure	2300-2550	–	7.0	–	–	7.0	–	dB
Output third order intercept point	2300-2550	–	+50	–	–	+50	–	dBm
	2400-2500	–	+51	–	–	+51	–	
Input VSWR	2300-2550	–	1.3	–	–	1.3	–	:1
	2400-2500	–	1.2	–	–	1.2	–	
Output VSWR	2300-2550	–	1.3	–	–	1.3	–	:1
	2400-2500	–	1.2	–	–	1.2	–	
DC Supply Voltage	2300-2550	–	28	29	–	28	29	V
Supply Current ¹	2300-2550	–	3.2	4.3	–	3.2	4.0	A

1. Small signal input power -35 dBm typ.
2. Power Supply should be capable of delivering 7.5A at start up.

[▲] Heat sink and fan not included. Alternative heat sinking and heat removal must be provided by the user to limit maximum base-plate temperature to 60°C, in order to ensure proper performance. For reference, this requires thermal resistance of user's external heat sink to be 0.157°C/W max.

ABSOLUTE MAXIMUM RATINGS

Parameter	Ratings
Ambient Operating Temperature ³	-20 °C to 41 °C
Storage Temperature	-55 °C to 100 °C
Base Plate Temperature	-20 °C to 60 °C
Input RF Power (no damage)	+9 dBm

3. For ZHL-30W-262-S+ (with heatsink and fan) only. Permanent damage may occur if any of these limits are exceeded.

D-SUB MALE CONNECTOR PIN CONNECTIONS³

Pin Function	Label on unit	Pin #	Color	Gauge
None	N/C1, N/C2 N/C4, N/C5	1,2,4,5	None	None
Thermal Shut-Off Indication: Shut-Off: +2 to +5V Not Shut-Off: 0 to +0.8V	TTL Out	3	Orange	28 AWG
DC Input (+)	Vdc	6,7	Red	18 AWG
Ground	GND	8,9	Black	18 AWG

3. Each amplifier will come packaged with an additional D-Sub connector for mating with the amplifier.





COAXIAL

High Power Amplifier

ZHL-30W-262-S+ ZHL-30W-262X-S+

Mini-Circuits

50Ω 30W 2300 to 2550 MHz

CASE STYLE DRAWING

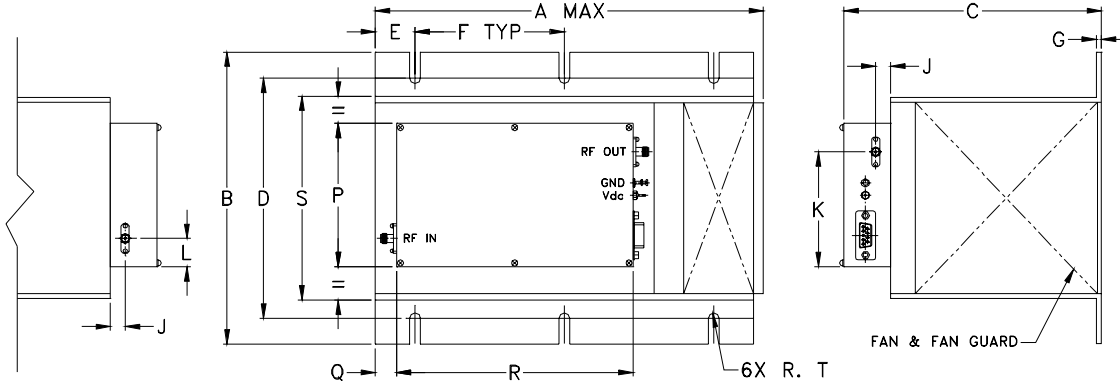

MOUNTING INFORMATION FOR MODELS WITHOUT HEATSINK.

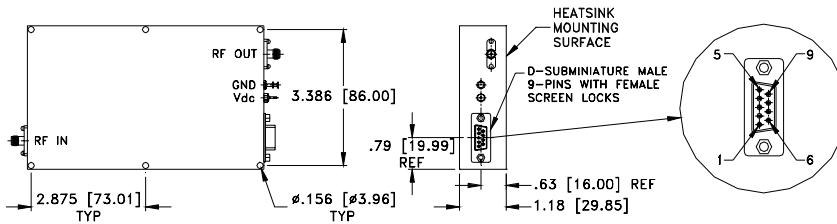

OUTLINE DIMENSIONS (Inch mm)

A	B	C	D	E	F	G	J	K	L	P	Q	R	S	T	wt
9.85	7.3	6.5	6.00	1.00	3.75	.13	.37	2.87	.71	3.58	.5	5.95	5.1	.135 grams*	
250.19	185.42	165.10	152.40	25.40	95.25	3.30	9.40	72.90	18.03	90.93	12.70	151.13	129.54	3.43	4265

*580 grams without heatsink



COAXIAL

High Power Amplifier

ZHL-30W-262-S+ ZHL-30W-262X-S+

50Ω 30W 2300 to 2550 MHz

TYPICAL PERFORMANCE DATA / GRAPHS

Frequency (MHz)	Gain (dB)	Directivity (dB)	VSWR (:1)		Noise Figure (dB)	POUT (dBm)		Output IP3 (dBm)
			IN	OUT		1 dB Compr.	3 dB Compr.	
2200.00	47.93	46.39	1.78	1.52	7.53	41.85	43.75	50.73
2250.00	48.55	38.56	1.67	1.36	7.62	43.19	44.86	51.03
2300.00	49.18	54.37	1.55	1.24	7.63	43.79	45.75	51.77
2350.00	49.79	59.76	1.46	1.16	7.60	43.86	46.04	51.93
2400.00	50.27	40.46	1.37	1.19	7.62	43.80	45.85	51.65
2420.00	50.36	46.57	1.34	1.21	7.60	43.61	45.90	51.44
2440.00	50.36	46.32	1.33	1.24	7.53	43.68	45.86	51.35
2460.00	50.28	42.92	1.31	1.27	7.59	43.88	45.99	51.40
2480.00	50.08	45.43	1.30	1.30	7.53	44.07	45.97	51.20
2500.00	49.70	45.12	1.29	1.32	7.51	43.84	45.84	51.12
2550.00	47.85	42.96	1.31	1.36	7.63	43.53	44.94	50.55

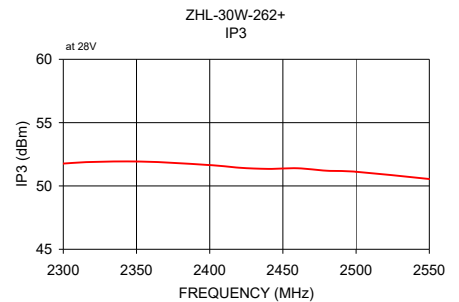
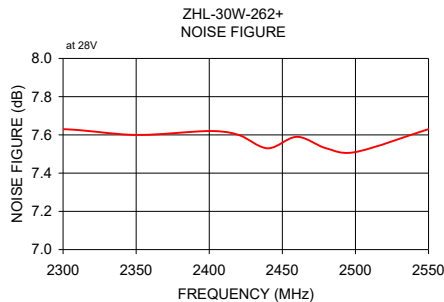
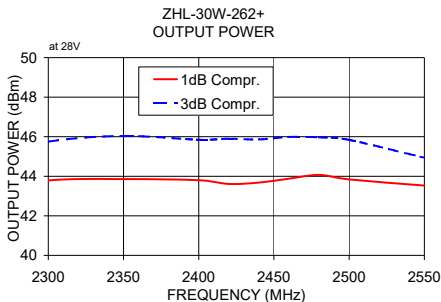
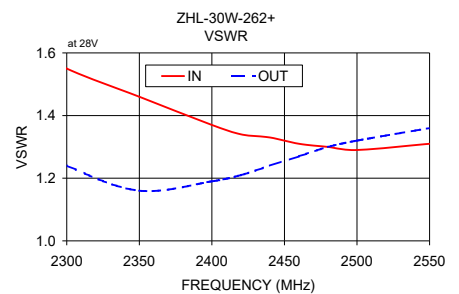
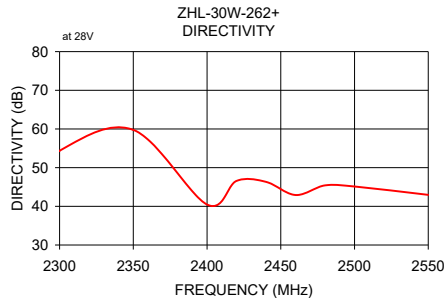
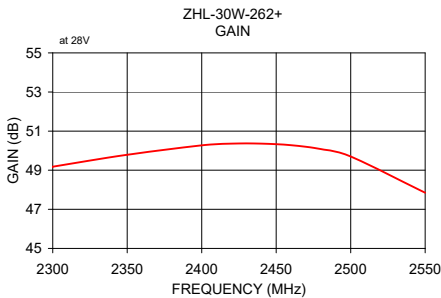

- NOTES**
- A. Performance and quality attributes and conditions not expressly stated in this specification document are intended to be excluded and do not form a part of this specification document.
 - B. Electrical specifications and performance data contained in this specification document are based on Mini-Circuit's applicable established test performance criteria and measurement instructions.
 - C. The parts covered by this specification document are subject to Mini-Circuits standard limited warranty and terms and conditions (collectively, "Standard Terms"); Purchasers of this part are entitled to the rights and benefits contained therein. For a full statement of the standard terms and the exclusive rights and remedies thereunder, please visit Mini-Circuits' website at www.minicircuits.com/terms/viewterm.html



High Power Amplifier

ZHL-30W-262+

Typical Performance Data

FREQ. (MHz)	GAIN (dB) 28V	DIRECTIVITY (dB) 28V	VSWR (:1)		NOISE FIGURE (dB) 28V	POUT @ 1 dB COMPRESSION (dBm) 28V	POUT @ 3 dB COMPRESSION (dBm) 28V	OUTPUT IP3 (dBm) 28V
			IN 28V	OUT 28V				
2200.0	47.93	46.39	1.78	1.52	7.53	41.85	43.75	50.73
2250.0	48.55	38.56	1.67	1.36	7.62	43.19	44.86	51.03
2300.0	49.18	54.37	1.55	1.24	7.63	43.79	45.75	51.77
2350.0	49.79	59.76	1.46	1.16	7.60	43.86	46.04	51.93
2400.0	50.27	40.46	1.37	1.19	7.62	43.80	45.85	51.65
2420.0	50.36	46.57	1.34	1.21	7.60	43.61	45.90	51.44
2440.0	50.36	46.32	1.33	1.24	7.53	43.68	45.86	51.35
2460.0	50.28	42.92	1.31	1.27	7.59	43.88	45.99	51.40
2480.0	50.08	45.43	1.30	1.30	7.53	44.07	45.97	51.20
2500.0	49.70	45.12	1.29	1.32	7.51	43.84	45.84	51.12
2550.0	47.85	42.96	1.31	1.36	7.63	43.53	44.94	50.55



P.O. Box 350166, Brooklyn, New York 11235-0003 (718) 934-4500 • Fax (718) 332-4661 For detailed performance specs & shopping online see Mini-Circuits web site
 The Design Engineers Search Engine Provides ACTUAL Data Instantly From MINI-CIRCUITS At: www.minicircuits.com

IF/RF MICROWAVE COMPONENTS

REV. X1
ZHL-30W-262+
4/23/2010
Page 1 of 1

High Power Amplifier

ZHL-30W-262+

Typical Performance Curves

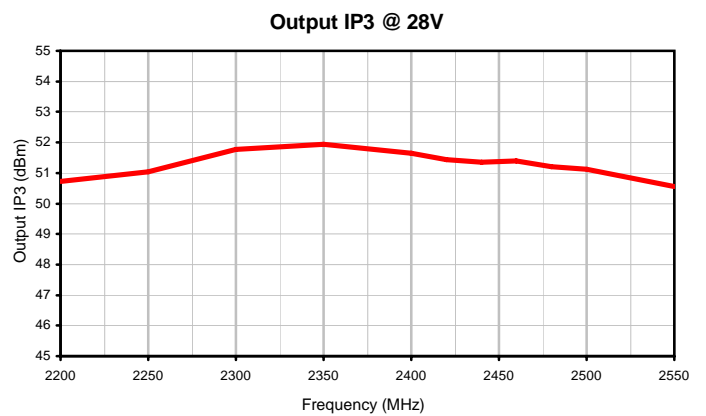
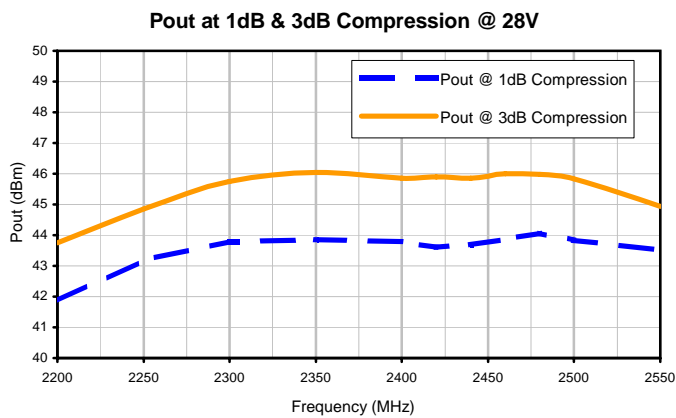
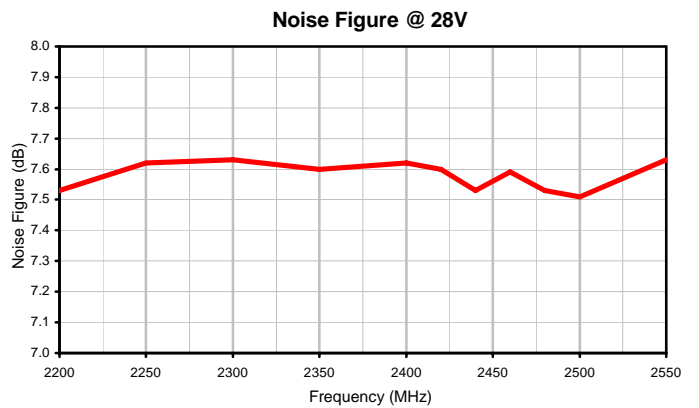
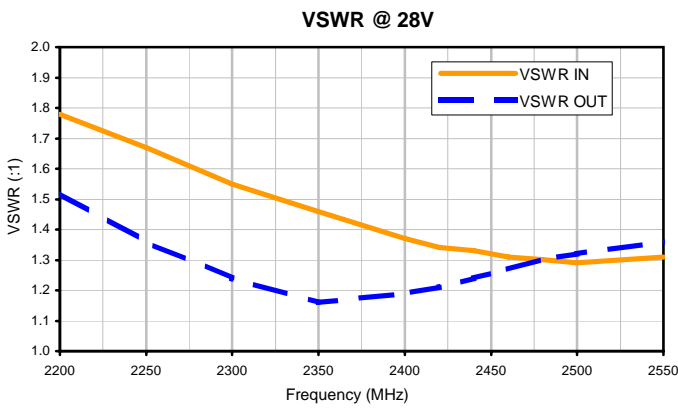
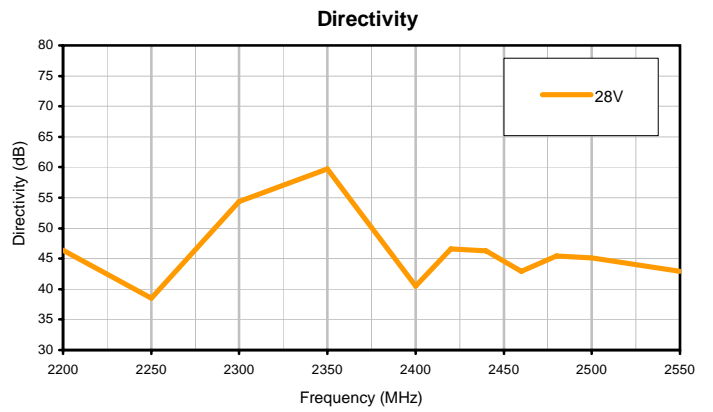
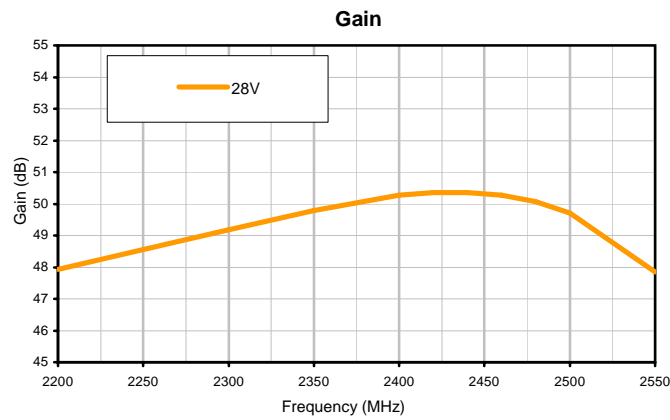

P.O. Box 350166, Brooklyn, New York 11235-0003 (718) 934-4500 • Fax (718) 332-4661 For detailed performance specs & shopping online see Mini-Circuits web site
 The Design Engineers Search Engine Provides ACTUAL Data Instantly From MINI-CIRCUITS At: www.minicircuits.com



IF/RF MICROWAVE COMPONENTS

REV. X1
 ZHL-30W-262+
 4/23/2010
 Page 1 of 1

Outline Dimensions

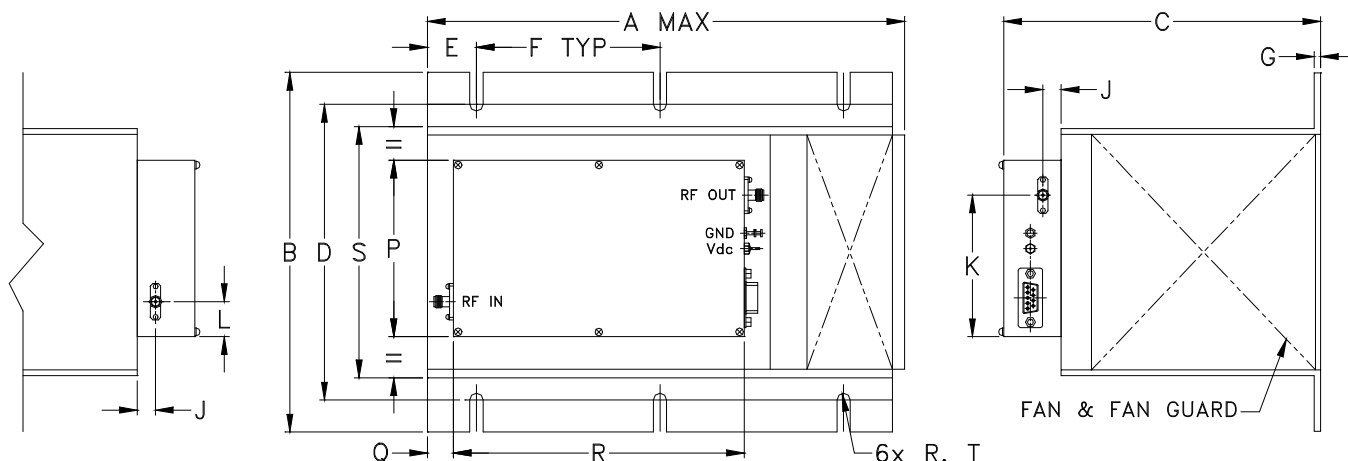

MOUNTING INFORMATION FOR MODELS WITHOUT HEATSINK.

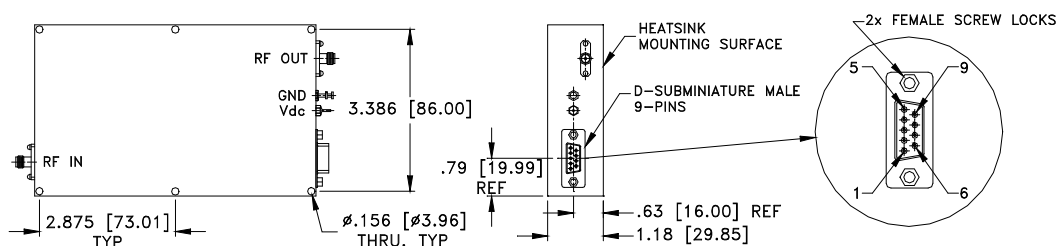

CASE#	A	B	C	D	E	F	G	H	J	K	L	M	N
BT1344	9.85 (250.19)	7.3 (185.42)	6.5 (165.10)	6.00 (152.40)	1.00 (25.40)	3.75 (95.25)	.13 (3.30)	-	.37 (9.40)	2.87 (72.90)	.71 (18.03)	-	-

CASE#	P	Q	R	S	T	WT, GRAM	WT WITHOUT HEATSINK, GRAM
BT1344	3.58 (90.93)	.5 (12.70)	5.95 (151.13)	5.1 (129.54)	.135 (3.43)	4265	580

Dimensions are in inches (mm). Tolerances: 1 Pl. $\pm .1$; 2 Pl. $\pm .03$; 3 Pl. $\pm .015$

Notes:

- Case material: Aluminum alloy.
- Finish:
For RoHS Case Styles: Clear Chemical conversion coating, non-chrome or trivalent chrome based.
- Heatsink finish: Black anodize.
- Refer to the individual model data sheet for the type of connectors available.
- Recommended screws for mounting model without heat sink on 3/32" thick sheet: #6-32, 1.50" Length.



P.O. Box 350166, Brooklyn, New York 11235-0003 (718) 934-4500 Fax (718) 332-4661 For detailed performance specs & shopping online see Mini-Circuits web site



The Design Engineers Search Engine Provides ACTUAL Data Instantly From MINI-CIRCUITS At: www.minicircuits.com

RF/IF MICROWAVE COMPONENTS



All Mini-Circuits products are manufactured under exacting quality assurance and control standards, and are capable of meeting published specifications after being subjected to any or all of the following physical and environmental test.

Specification	Test/Inspection Condition	Reference/Spec
Operating Temperature	-20° to 60°C Base Plate Temperature	Individual Model Data Sheet
Storage Temperature	-55° to 100° C Ambient Environment	Individual Model Data Sheet
Stabilization Bake	(non-operating) 125°C, 24 hours	- - -
Burn-in at Elevated Temp.	(DC on) 160 hours at 60° C	MIL-STD-202, Method 108
Thermal Shock	-55° to 100°C, 5 cycles	MIL-STD-202, Method 107, Condition A, except 100°C