



COAXIAL

# High Power Amplifier

## ZHL-30W-252-S+ ZHL-30W-252X-S+

50Ω 30W 600 to 2500 MHz

### THE BIG DEAL

- High Power, 30 Watt
- Low Current consumption, 5A typ.
- High IP3, +52 dBm typ.
- Useable over 500 to 2600 MHz
- Good Gain Flatness, ±1.0 dB typ.
- No damage with an open or short output load under full CW output power
- Shuts off when base plate temperature exceeds +80°C
- Accepts wide range of DC supply voltage +25V to +29V



Generic photo used for illustration purposes only

<b>Model No.</b>	ZHL-30W-252-S+	ZHL-30W-252X-S+ <sup>▲</sup>
<b>Case Style</b>	BT1344	
<b>Connectors</b>	SMA / D-Sub Male	

### APPLICATIONS

- Cellular
- PCN
- GSM
- ISM
- Lab Test



### PRODUCT OVERVIEW

Mini-Circuits' ZHL-30W-252+ is a high-power connectorized amplifier supporting a wide range of applications from 600 to 2500 MHz, such as test instrumentation, SatCom, and mobile communications systems, including those operating in the new telecom Band 71 allocation (617 to 698 MHz). This model provides +46 dBm output power at saturation and extremely flat gain (50 ±1.3 dB) across its full bandwidth, making it ideal for systems where consistent performance across frequency is required. The amplifier operates on a 28V DC supply and comes housed in compact aluminum alloy case (9.85 x 7.3 x 6.5") with SMA connectors, and an optional heat sink and fan for efficient cooling.

### KEY FEATURES

Feature	Advantages
Wideband, 600 to 2500 MHz	One amplifier supports a broad range of system and test lab applications. Extended bandwidth down to 600 MHz supports new Telecom Band 71 allocation (617 to 698 MHz)
High Gain, 50 dB	Reduces the number of gain stages, lowering component count and overall system cost.
Excellent Gain Flatness, ±1.0 dB	Provides consistent performance across frequency, minimizing the need for external equalizing networks in wideband applications.
High Output Power, +46 dBm P3dB	Supports a wide range of power requirements.
High OIP3, +52 dBm	Provides highly linear performance with excellent sensitivity and two-tone spur-free dynamic range.
Built-in protections	The unit features immunity to open and short loads under full CW output power and automatically shuts off when the base plate temperature exceeds +80°C.





COAXIAL

# High Power Amplifier

# ZHL-30W-252-S+ ZHL-30W-252X-S+

50Ω 30W 600 to 2500 MHz

## ELECTRICAL SPECIFICATIONS

Parameter	ZHL-30W-252-S+			ZHL-30W-252X-S+ <sup>▲</sup>			Units
	Min.	Typ.	Max.	Min	Typ.	Max.	
Frequency Range	600	—	2500	600	—	2500	MHz
Gain <sup>1</sup>	47	50	55	47	50	55	dB
Gain Flatness	—	—	±2.0	—	—	±2.0	dB
Output Power at 1dB compression	—	+44	—	—	+44	—	dBm
Saturated Output Power at 3dB compression	+44	+46	—	+44	+46	—	dBm
Noise Figure	—	5.5	—	—	5.5	—	dB
Output third order intercept point	—	+52	—	—	+52	—	dBm
Input VSWR	—	1.3	—	—	1.3	—	:1
Output VSWR	—	1.2	—	—	1.2	—	:1
DC Supply Voltage	—	28	29	—	28	29	V
Supply Current <sup>2</sup>	—	—	6.3	—	—	6.0	A

1. Small signal input power -35 dBm typ.
2. Power Supply should be capable of delivering 7.5A at start up.

<sup>▲</sup> Heat sink and fan not included. Alternative heat sinking and heat removal must be provided by the user to limit maximum base-plate temperature to 85°C, in order to ensure proper performance. For reference, this requires thermal resistance of user's external heat sink to be 0.2°C/W max.

## ABSOLUTE MAXIMUM RATINGS

Parameter	Ratings
Operating Temperature	-20 °C to 60 °C
Storage Temperature	-55 °C to 100 °C
Base Plate Temperature	85 °C
Input RF Power (no damage)	0 dBm

Permanent damage may occur if any of these limits are exceeded.

## D-SUB MALE CONNECTOR PIN CONNECTIONS<sup>3</sup>

Pin Function	Label on unit	Pin #	Color	Gauge
None	N/C1, N/C2 N/C4, N/C5	1,2,4,5	None	None
Thermal Shut-Off Indication: Shut-Off: +2 to +5V Not Shut-Off: 0 to +0.8V	TTL Out	3	Orange	26 AWG
DC Input (+)	Vdc	6,7	Red	18 AWG
Ground	GND	8,9	Black	18 AWG

3. Each amplifier will come packaged with an additional D-Sub connector for mating with the amplifier.





COAXIAL

# High Power Amplifier

**ZHL-30W-252-S+**  
**ZHL-30W-252X-S+**

Mini-Circuits

50Ω 30W 600 to 2500 MHz

## CASE STYLE DRAWING

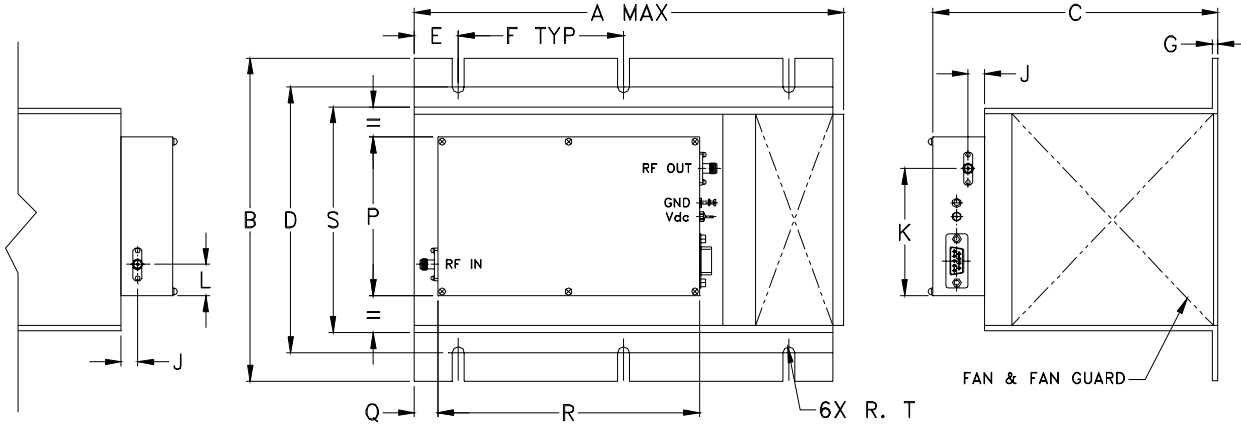

## MOUNTING INFORMATION FOR MODELS WITHOUT HEATSINK.

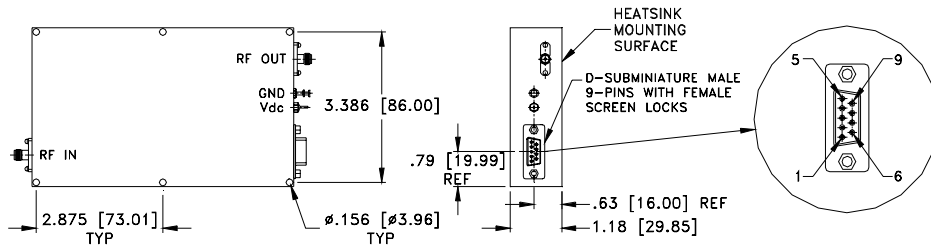

## OUTLINE DIMENSIONS (Inch mm)

A	B	C	D	E	F	G	J	K	L	P	Q	R	S	T	wt
9.85	7.3	6.5	6.00	1.00	3.75	.13	.37	2.87	.71	3.58	.5	5.95	5.1	.135	grams*
250.19	185.42	165.10	152.40	25.40	95.25	3.30	9.40	72.90	18.03	90.93	12.70	151.13	129.54	3.43	4265
															*580 grams without heatsink



COAXIAL

# High Power Amplifier

## ZHL-30W-252-S+ ZHL-30W-252X-S+

50Ω 30W 600 to 2500 MHz

### TYPICAL PERFORMANCE DATA / GRAPHS

Frequency (MHz)	Gain (dB)	Directivity (dB)	VSWR (:1)		Noise Figure (dB)	POUT (dBm)	Output IP3 (dBm)
	28V	28V	IN	OUT	28V	28V	28V
600	49.25	43.44	1.53	1.29	5.56	42.48	50.94
700	49.38	49.04	1.53	1.07	5.62	43.82	51.67
800	49.61	57.64	1.42	1.08	5.58	43.97	52.24
900	50.28	53.57	1.37	1.10	5.52	43.39	52.05
1000	50.84	47.78	1.45	1.06	5.44	43.30	52.15
1200	51.43	48.87	1.56	1.04	5.43	44.86	52.65
1400	50.87	54.00	1.56	1.08	5.31	46.31	53.33
1600	50.21	49.94	1.43	1.21	5.42	44.05	52.25
1800	51.57	40.56	1.33	1.16	5.64	44.96	51.89
2000	51.24	43.12	1.25	1.14	5.78	44.51	51.56
2200	50.67	43.78	1.25	1.07	5.77	44.98	51.45
2400	50.53	45.23	1.16	1.18	5.82	43.80	51.78
2500	51.17	41.20	1.15	1.36	5.81	43.53	51.76

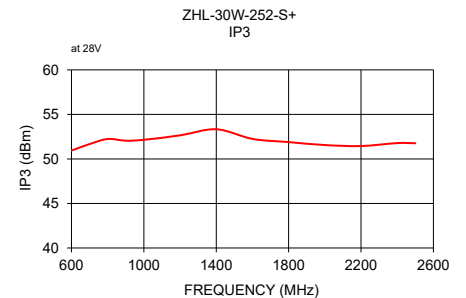
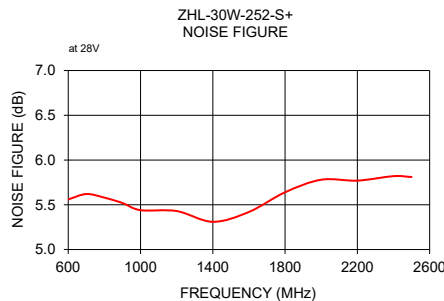
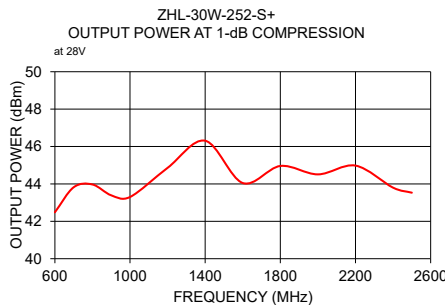
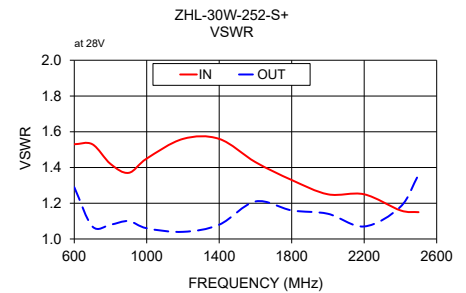
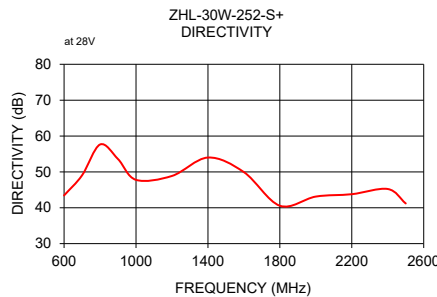
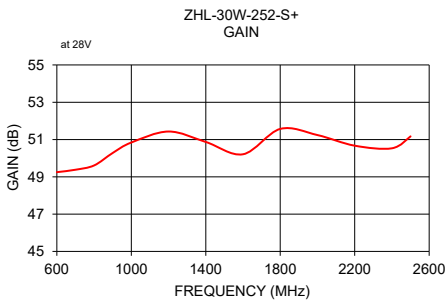

#### NOTES

- A. Performance and quality attributes and conditions not expressly stated in this specification document are intended to be excluded and do not form a part of this specification document.
- B. Electrical specifications and performance data contained in this specification document are based on Mini-Circuit's applicable established test performance criteria and measurement instructions.
- C. The parts covered by this specification document are subject to Mini-Circuits standard limited warranty and terms and conditions (collectively, "Standard Terms"); Purchasers of this part are entitled to the rights and benefits contained therein. For a full statement of the standard terms and the exclusive rights and remedies thereunder, please visit Mini-Circuits' website at [www.minicircuits.com/terms/viewterm.html](http://www.minicircuits.com/terms/viewterm.html)



# Coaxial Amplifier

# ZHL-30W-252+

## Typical Performance Data

FREQUENCY (MHz)	GAIN (dB) 28V	DIRECTIVITY (dB) 28V	VSWR IN (:1) 28V	VSWR OUT (:1) 28V	NOISE FIGURE (dB) 28V	Pout at 1dB COMP. (dBm) 28V	OUTPUT IP3 (dBm) 28V
600.0	49.25	43.44	1.53	1.29	5.56	42.48	50.94
700.0	49.38	49.04	1.53	1.07	5.62	43.82	51.67
800.0	49.61	57.64	1.48	1.08	5.58	43.97	52.24
900.0	50.28	53.57	1.42	1.10	5.52	43.39	52.05
1000.0	50.84	47.78	1.37	1.06	5.44	43.30	52.15
1200.0	51.43	48.87	1.45	1.04	5.43	44.86	52.65
1400.0	50.87	54.00	1.56	1.08	5.31	46.31	53.33
1600.0	50.21	49.94	1.56	1.21	5.42	44.48	52.25
1800.0	51.57	40.56	1.43	1.16	5.64	44.96	51.89
2000.0	51.24	43.12	1.33	1.11	5.78	44.51	51.56
2200.0	50.67	43.78	1.25	1.07	5.77	44.98	51.45
2400.0	50.53	45.23	1.16	1.18	5.82	43.80	51.78
2500.0	51.17	41.20	1.15	1.36	5.81	43.53	51.76

# Coaxial Amplifier

# ZHL-30W-252+

## Typical Performance Curves

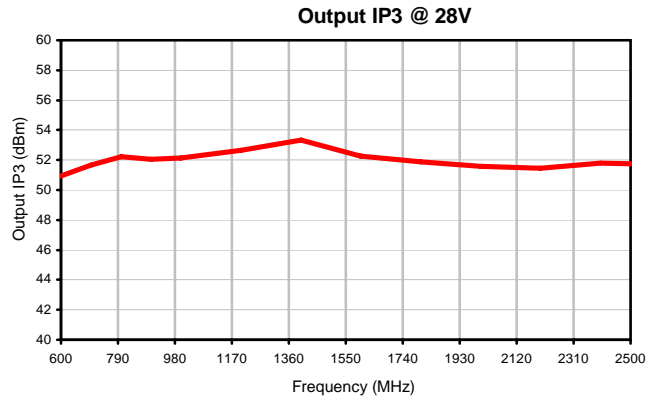
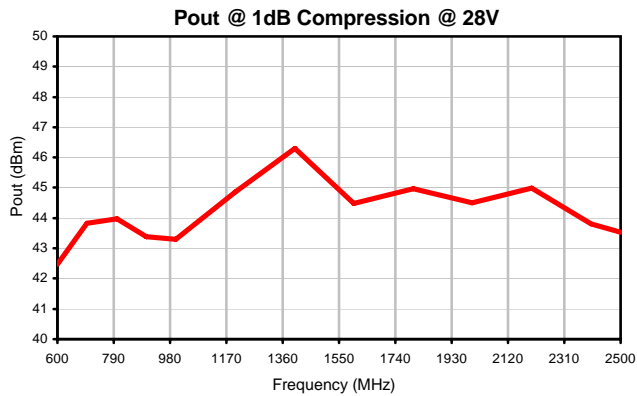
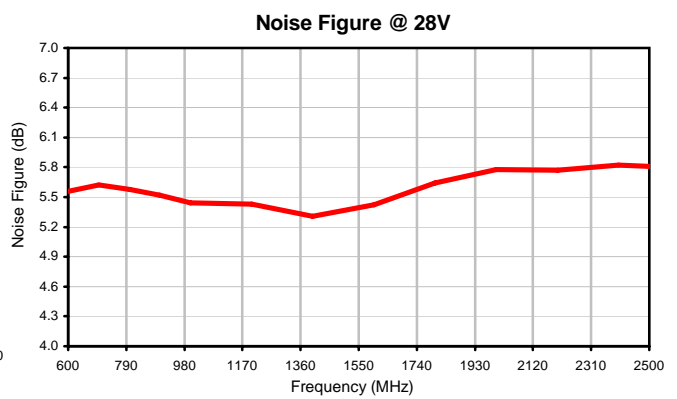
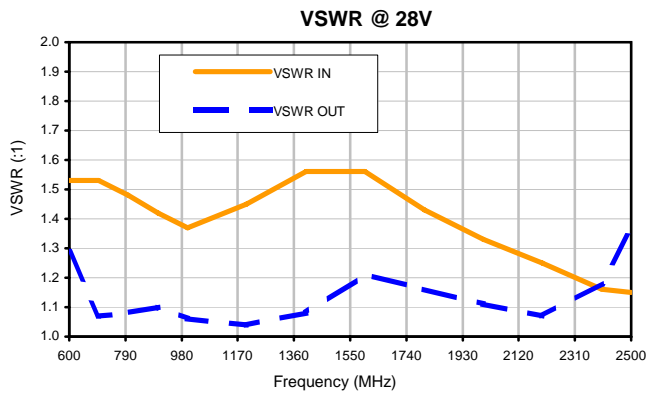
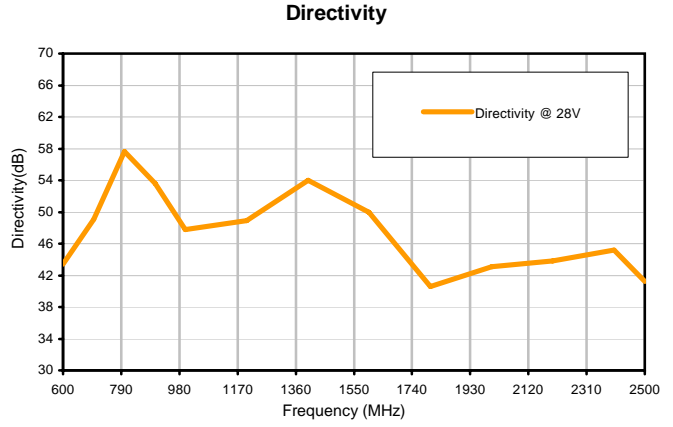
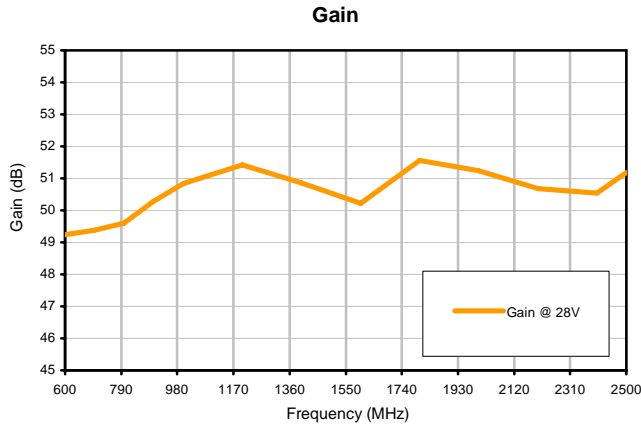

### Outline Dimensions

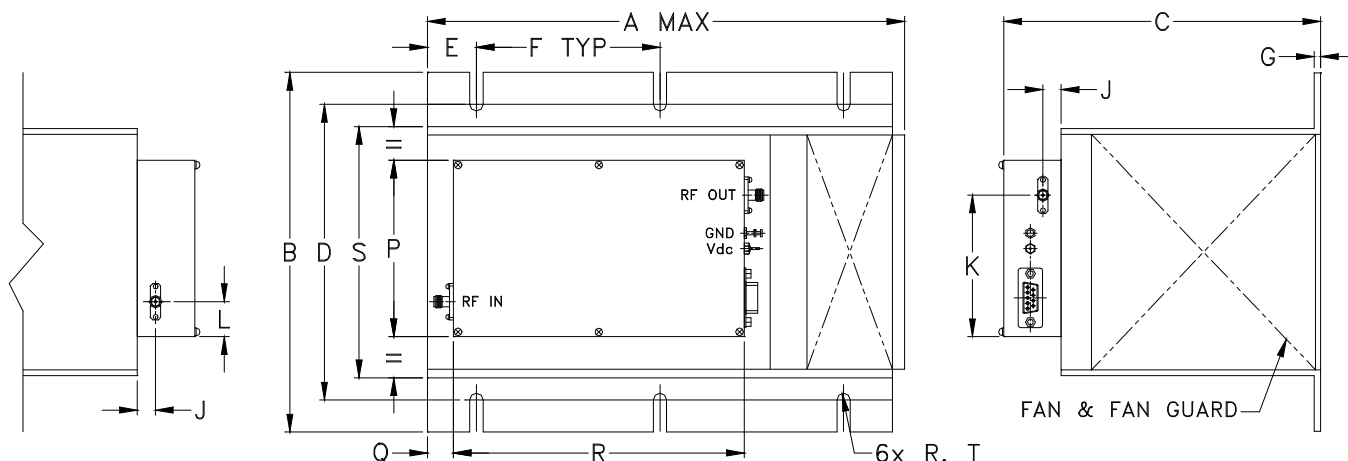

### MOUNTING INFORMATION FOR MODELS WITHOUT HEATSINK.

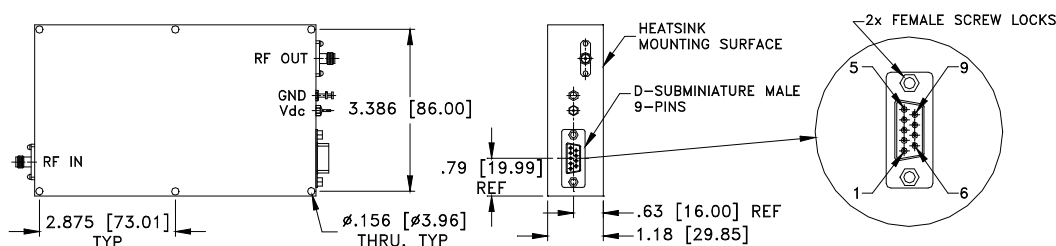

CASE#	A	B	C	D	E	F	G	H	J	K	L	M	N
BT1344	9.85 (250.19)	7.3 (185.42)	6.5 (165.10)	6.00 (152.40)	1.00 (25.40)	3.75 (95.25)	.13 (3.30)	-	.37 (9.40)	2.87 (72.90)	.71 (18.03)	-	-

CASE#	P	Q	R	S	T	WT, GRAM	WT WITHOUT HEATSINK, GRAM
BT1344	3.58 (90.93)	.5 (12.70)	5.95 (151.13)	5.1 (129.54)	.135 (3.43)	4265	580

Dimensions are in inches (mm). Tolerances: 1 Pl.  $\pm .1$ ; 2 Pl.  $\pm .03$ ; 3 Pl.  $\pm .015$

#### Notes:

- Case material: Aluminum alloy.
- Finish:  
For RoHS Case Styles: Clear Chemical conversion coating, non-chrome or trivalent chrome based.
- Heatsink finish: Black anodize.
- Refer to the individual model data sheet for the type of connectors available.
- Recommended screws for mounting model without heat sink on 3/32" thick sheet: #6-32, 1.50" Length.



P.O. Box 350166, Brooklyn, New York 11235-0003 (718) 934-4500 Fax (718) 332-4661 For detailed performance specs & shopping online see Mini-Circuits web site



The Design Engineers Search Engine Provides ACTUAL Data Instantly From MINI-CIRCUITS At: [www.minicircuits.com](http://www.minicircuits.com)

RF/IF MICROWAVE COMPONENTS



All Mini-Circuits products are manufactured under exacting quality assurance and control standards, and are capable of meeting published specifications after being subjected to any or all of the following physical and environmental test.

Specification	Test/Inspection Condition	Reference/Spec
Operating Temperature	-20° to 60°C Ambient Environment	Individual Model Data Sheet
Storage Temperature	-55° to 100° C Ambient Environment	Individual Model Data Sheet
Stabilization Bake	(non-operating) 125°C, 24 hours	- - -
Burn-in at Elevated Temp.	(DC on) 160 hours at 85° C	MIL-STD-202, Method 108
Thermal Shock	-55° to 100°C, 5 cycles	MIL-STD-202, Method 107, Condition A, except 100°C