



COAXIAL

High Power Amplifier

ZHL-25W-272+ ZHL-25W-272X+

50Ω 25W 20 to 2700 MHz SMA-Female

THE BIG DEAL

- High Power, 25 Watt at Saturation
- Class AB Amplifier
- Low Current Consumption
- High IP3, +49 dBm typ.
- Usable from 10 MHz to 2750 MHz
- Good Gain Flatness, ±1.0 dB typ.
- No damage with an open or short output load while delivering up to 15W
- Shuts off when base plate temperature exceeds +85°C



Generic photo used for illustration purposes only

Model No.	ZHL-25W-272+	ZHL-25W-272X+▲
Case Style	BT2119	
Connectors	SMA / Solderable pins/D-Sub Male	

+RoHS Compliant

The +Suffix identifies RoHS Compliance. See our website for methodologies and qualifications

APPLICATIONS

- Cellular
- PCN
- GSM
- ISM
- Lab Test

PRODUCT OVERVIEW

The ZHL-25W-272+ is a Class AB, high-power amplifier providing 25W saturated power over the 20 to 2700 MHz band, ideal for a variety of high-power test setups as well as applications including communications, radar and more. The ruggedly-designed amplifier provides unconditional stability and built-in self-protection against reverse polarity, excessive drive and overheating. The amplifier's output stage is further protected in the event of a fault condition, allowing high power operation for up to 5 minutes into an OPEN or SHORT load (refer to the maximum input power specifications). Housed in a rugged aluminum alloy case measuring 5.6 x 8.8 x 1.2", the unit features SMA connectors and an optional heat sink and fan attachment for cooling.

KEY FEATURES

Feature	Advantages
Wideband, usable from 10 to 2750 MHz	Suitable for a broad range of high-power, wideband applications, including test setups, communications and defense applications.
High Gain, 50 dB	Enables signal amplification to 25W output without the need for multiple gain stages.
Built-in self-protection	In instances of potentially-damaging excessive drive current, heat buildup within the housing, unshorting of DC supply, and short or open loads at the output, an automatic sensing feature signals the unit to power down.
Unconditional stability	Provides reliable performance independent of input and load conditions.

REV. B
ECO-018143
ZHL-25W-272+
MCL NY
231221





COAXIAL

High Power Amplifier

ZHL-25W-272+ ZHL-25W-272X+

Mini-Circuits

50Ω 25W 20 to 2700 MHz SMA-Female

ELECTRICAL SPECIFICATIONS AT 25°C

Parameter	ZHL-25W-272+			ZHL-25W-272X+ [▲]			Units
	Min.	Typ.	Max.	Min	Typ.	Max.	
Frequency Range	20		2700	20		2700	MHz
Gain ¹	44	50	56	44	50	56	dB
Gain Flatness	—	±1.0	±2.2		±1.0	±2.2	dB
Output Power at 1dB Compression	+35	+40	—	+35	+40	—	dBm
Output Power at Saturation	+42	+44	—	+42	+44	—	dBm
Noise Figure	—	10	—	—	10	—	dB
Output third order intercept point	+44	+49	—	+44	+49	—	dBm
Input VSWR	—	2.0	—	—	2.0	—	:1
Output VSWR	—	3.5	—	—	3.5	—	:1
DC Supply Voltage	—	+28	+30	—	+28	+30	V
Supply Current ²	—	3.7	6.7	—	3.5	6.5	A

1. Small signal input power -50 dBm typ.

2. Power Supply should be capable of delivering 10A at start up.

[▲] Heat sink and fan not included. Alternative heat sinking and heat removal must be provided by the user to limit maximum base-plate temperature to 85°C, in order to ensure proper performance. For reference, this requires thermal resistance of user's external heat sink to be 0.2°C/W max.

ABSOLUTE MAXIMUM RATINGS³

Parameter	Ratings
Operating Temperature	-20°C to +60°C
Storage Temperature	-55°C to +100°C
Base Plate Temperature	+85°C
Input RF Power (no damage)	+5 dBm ⁴
	-10 dBm ⁵

3. Specifications apply to CW signals only permanent damage may occur if any of these limits are exceeded.

4. Into 50 ohm load.

5. Into open or short load, for up to 5 minutes.

D-SUB MALE CONNECTOR PIN CONNECTIONS^{**}

Pin Function	Label on unit	Pin #	Color	Gauge
None	N/C1, N/C2, N/C3 N/C4, N/C5	1,2,4,5	None	None
<u>Thermal Shut-Off Indication</u> Shut-Off: +2 to +5V Not Shut-Off: 0 to +0.8V	TTL Out	3	Orange	26 AWG
DC Input (+)	Vdc	6,7	Red	18 AWG
Ground	GND	8,9	Black	18 AWG

^{**} Each amplifier includes an additional D-sub connector for mating with amplifier.





COAXIAL

High Power Amplifier

ZHL-25W-272+ ZHL-25W-272X+

Mini-Circuits

50Ω 25W 20 to 2700 MHz SMA-Female

OUTLINE DRAWING FOR MODELS WITH HEATSINK

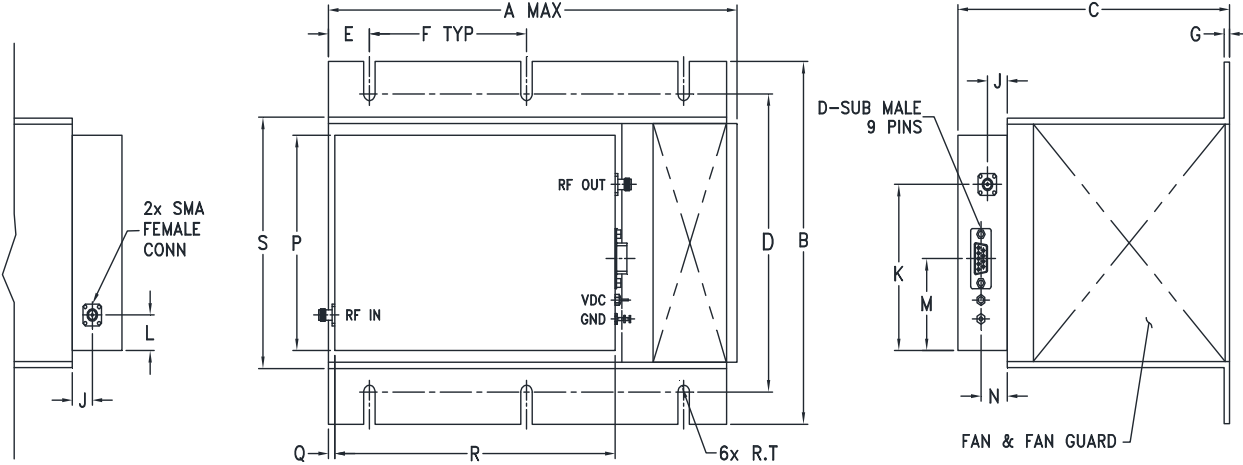

OUTLINE DRAWING FOR MODELS WITHOUT HEATSINK

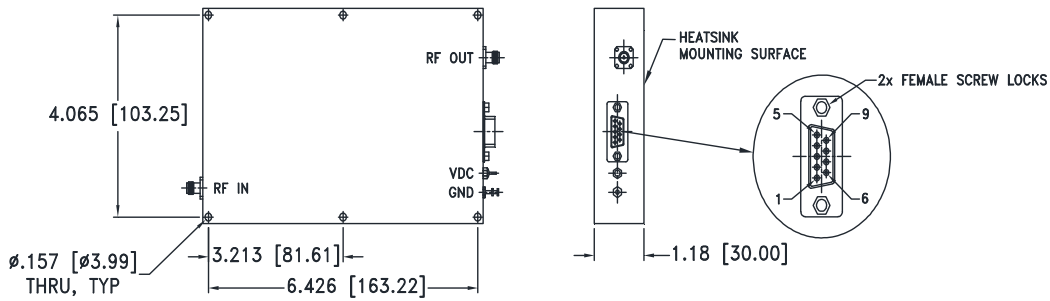

OUTLINE DIMENSIONS (Inch mm)

A	B	C	D	E	F	G	J	K	L	M	N	P	Q	R	S	T	wt
9.85	7.30	6.50	6.00	0.98	3.75	0.13	0.47	3.34	0.71	1.85	0.63	4.33	0.20	6.69	5.10	0.14	grams*
250.19	185.42	165.10	152.40	24.89	95.25	3.30	12.00	84.80	18.00	47.00	16.00	110.00	5.08	170.00	129.54	3.45	4565
																	*880 grams without heatsink

Tolerances: 1 Pl. +.1; 2 Pl. +.03; 3 Pl. +.015





COAXIAL

High Power Amplifier

ZHL-25W-272+ ZHL-25W-272X+

Mini-Circuits

50Ω 25W 20 to 2700 MHz SMA-Female

TYPICAL PERFORMANCE DATA/CURVES

FREQUENCY (MHz)	GAIN (dB)	DIRECTIVITY (dB)	VSWR (:1)		POUT at 1 dB COMPR. (dBm)	POUT at SAT (dBm)	NOISE FIGURE (dB)	OUTPUT IP3 (dBm)
	28V	28V	IN	OUT	28V	28V	28V	28V
20	49.60	37.40	1.38	3.88	40.10	43.30	12.90	49.80
100	48.90	51.40	1.43	4.10	40.30	43.50	10.70	48.80
500	48.50	52.00	1.07	4.90	38.20	44.30	9.70	47.00
1000	49.20	60.00	1.26	1.58	41.20	46.60	9.30	50.10
1500	48.30	53.70	1.17	1.37	41.70	46.70	9.30	50.70
2000	49.00	57.10	1.20	2.75	40.40	46.80	9.30	48.70
2500	49.00	58.90	1.12	1.47	43.00	47.10	9.60	49.60
2700	48.70	67.60	1.04	1.65	40.80	44.10	9.70	48.00

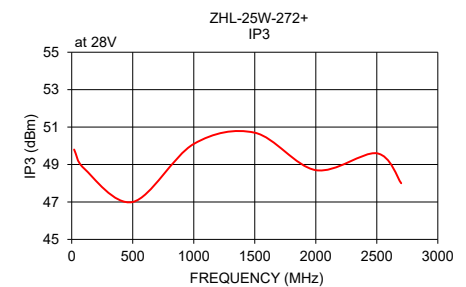
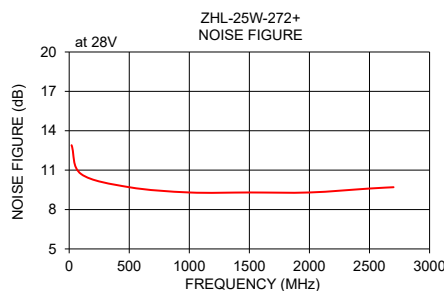
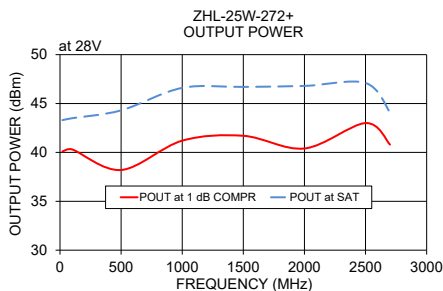
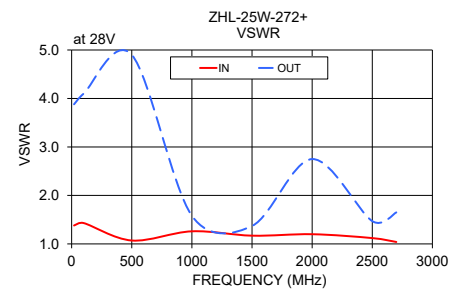
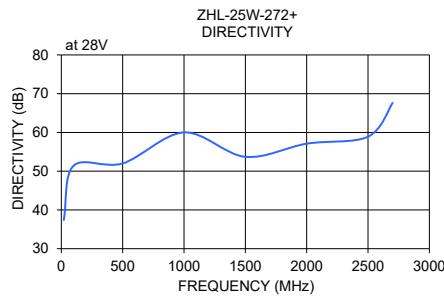
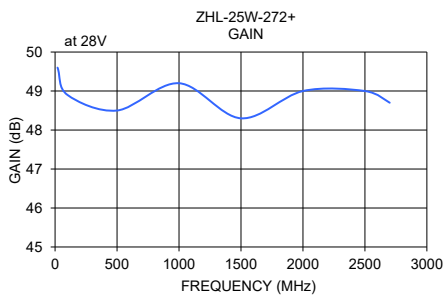

NOTES

- A. Performance and quality attributes and conditions not expressly stated in this specification document are intended to be excluded and do not form a part of this specification document.
- B. Electrical specifications and performance data contained in this specification document are based on Mini-Circuit's applicable established test performance criteria and measurement instructions.
- C. The parts covered by this specification document are subject to Mini-Circuits standard limited warranty and terms and conditions (collectively, "Standard Terms"); Purchasers of this part are entitled to the rights and benefits contained therein. For a full statement of the standard terms and the exclusive rights and remedies thereunder, please visit Mini-Circuits' website at www.minicircuits.com/terms/viewterm.html



Typical Performance Data

Frequency (MHz)	Gain (dB) 28V	Directivity (dB) 28V	VSWR In (:1) 28V	VSWR Out (:1) 28V	Noise Figure (dB) 28V	Pout at 1dB Compression (dBm) 28V	Pout at Saturation (dBm) 28V	Output IP3 (dBm) 28V
10	49.89	38.44	1.40	3.80	14.33	40.35	43.07	49.73
20	49.64	37.40	1.38	3.84	12.88	40.11	43.29	49.83
30	49.53	41.03	1.39	3.86	11.98	40.35	43.20	49.45
40	49.33	41.69	1.42	3.91	11.63	40.50	43.39	49.54
50	49.33	29.08	1.46	3.96	11.44	40.31	43.24	49.78
60	49.23	71.40	1.42	4.01	11.43	40.49	43.50	49.81
70	49.17	54.55	1.43	4.06	11.03	40.45	43.58	49.51
80	48.80	46.22	1.43	4.10	11.03	40.48	43.62	49.13
90	48.80	53.36	1.43	4.14	11.03	40.27	43.42	49.02
100	48.92	51.40	1.43	4.16	10.74	40.26	43.48	48.81
150	49.35	50.69	1.42	4.20	10.24	39.95	43.50	48.66
200	49.64	54.19	1.39	4.18	10.10	39.79	43.36	48.55
250	49.73	50.36	1.34	4.14	9.85	39.54	43.09	47.89
300	49.66	45.48	1.29	4.10	9.78	39.41	43.38	47.92
350	49.44	53.11	1.24	3.98	9.63	38.79	43.69	47.55
400	48.97	68.38	1.18	4.40	9.48	38.66	44.26	47.46
450	48.32	49.88	1.12	4.83	9.62	37.80	44.20	46.99
500	48.34	50.77	1.08	4.85	9.52	38.25	44.60	47.05
550	48.97	51.40	1.04	5.08	9.60	38.32	44.41	46.97
600	50.22	52.41	1.05	4.92	9.54	38.95	45.12	47.52
650	50.77	61.70	1.09	4.42	9.49	39.28	45.17	47.13
700	49.27	48.36	1.13	3.82	9.60	40.03	45.93	47.70
750	47.68	57.64	1.16	3.22	9.48	39.76	45.92	47.66
800	47.65	55.69	1.20	2.81	9.50	40.22	46.32	48.54
850	48.14	52.89	1.23	2.34	9.43	40.25	45.90	48.82
900	48.62	54.73	1.25	2.04	9.35	40.80	46.25	49.49
950	49.00	60.09	1.26	1.80	9.36	40.69	46.28	49.47
1000	49.16	52.48	1.25	1.60	9.24	41.36	46.81	50.11
1050	49.17	61.35	1.25	1.50	9.35	41.09	46.55	49.90
1100	49.04	50.64	1.24	1.35	9.25	41.65	46.57	50.42
1150	48.76	57.81	1.22	1.22	9.22	41.28	45.60	50.34
1200	48.38	57.73	1.19	1.11	9.23	41.61	45.70	50.66
1250	48.01	53.77	1.17	1.02	9.19	41.52	45.69	50.63
1300	47.67	52.39	1.15	1.10	9.19	41.62	45.76	50.67
1350	47.39	58.90	1.14	1.20	9.22	41.56	45.64	50.54
1400	47.44	62.35	1.15	1.22	9.27	41.66	45.36	50.71
1450	47.72	52.35	1.16	1.28	9.26	41.89	45.84	50.75
1500	48.12	50.54	1.16	1.33	9.45	41.72	46.32	50.78
1550	48.58	60.49	1.15	1.40	9.33	41.97	46.90	50.82
1600	49.02	55.89	1.14	1.49	9.28	41.65	46.99	50.32
1650	49.48	51.27	1.12	1.60	9.32	41.72	46.98	50.08
1700	49.83	52.39	1.11	1.74	9.38	41.64	46.67	49.51
1750	50.04	55.43	1.11	1.90	9.32	41.65	46.96	49.45
1800	50.14	70.06	1.13	2.09	9.29	41.36	46.93	49.01
1850	49.98	59.31	1.15	2.30	9.31	41.41	47.09	49.24
1900	49.64	63.51	1.17	2.47	9.35	41.09	47.07	48.72
1950	49.34	48.22	1.19	2.61	9.26	40.87	47.07	48.71
2000	49.06	68.17	1.20	2.71	9.32	40.70	47.07	48.59
2050	48.92	61.46	1.20	2.76	9.39	40.44	46.83	48.58
2100	48.89	50.37	1.18	2.80	9.35	40.60	46.91	48.75
2150	48.95	49.77	1.16	2.80	9.29	41.12	46.98	48.63
2200	49.03	53.51	1.13	2.74	9.51	41.68	47.18	49.13
2250	49.22	53.69	1.09	2.62	9.35	42.10	47.30	49.24
2300	49.40	49.28	1.05	2.46	9.43	42.73	47.61	49.61
2350	49.58	59.61	1.03	2.28	9.40	43.20	47.80	49.72
2400	49.63	53.49	1.07	2.06	9.46	43.47	47.89	50.04
2450	49.52	49.61	1.10	1.82	9.35	43.45	47.71	49.72
2500	49.19	54.92	1.11	1.56	9.47	43.13	47.29	49.75
2550	48.73	45.39	1.12	1.33	9.53	42.71	46.61	49.42
2600	48.16	55.51	1.10	1.22	9.55	42.08	45.63	48.98
2650	47.58	53.53	1.06	1.33	9.66	41.55	45.17	48.68
2700	48.70	67.57	1.04	1.65	9.68	40.83	44.09	48.13
2750	49.50	44.87	1.18	1.85	9.51	40.11	43.55	47.76



P.O. Box 350166, Brooklyn, New York 11235-0003 (718) 934-4500 • Fax (718) 332-4661 For detailed performance specs & shopping online see Mini-Circuits web site



The Design Engineers Search Engine Provides ACTUAL Data Instantly From MINI-CIRCUITS At: www.minicircuits.com

IF/RF MICROWAVE COMPONENTS

REV. OR
ZHL-25W-272+
8/2/2017
Page 1 of 1

Typical Performance Curves

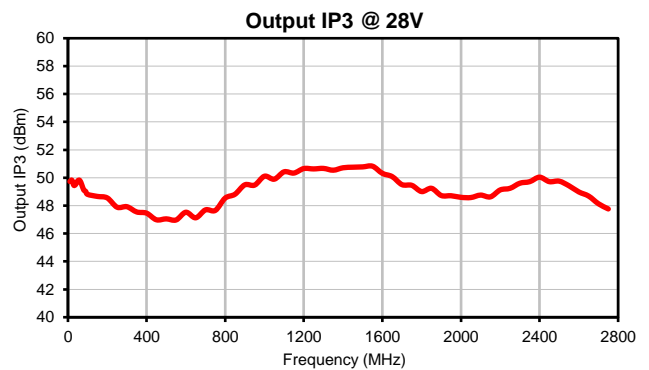
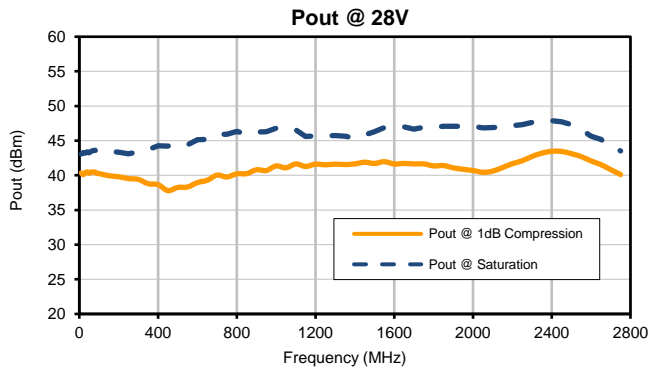
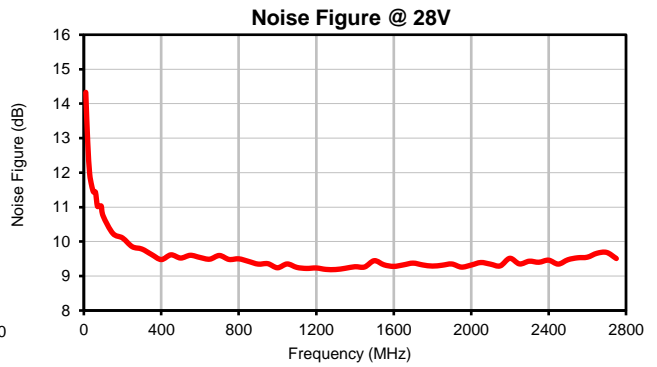
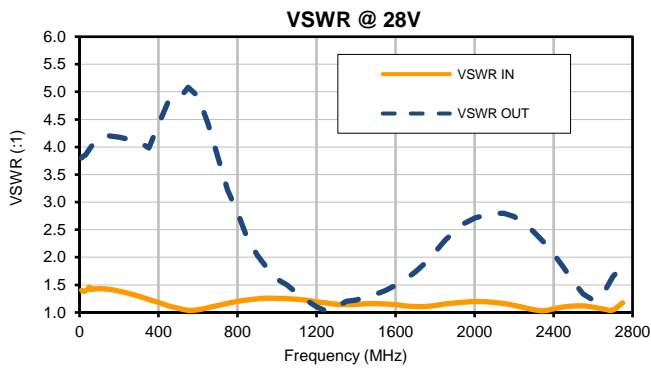
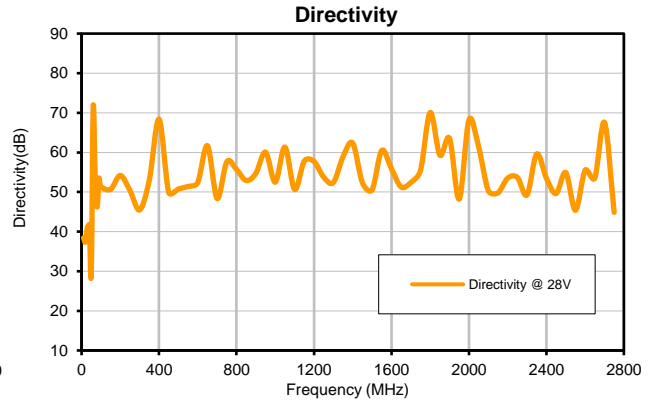
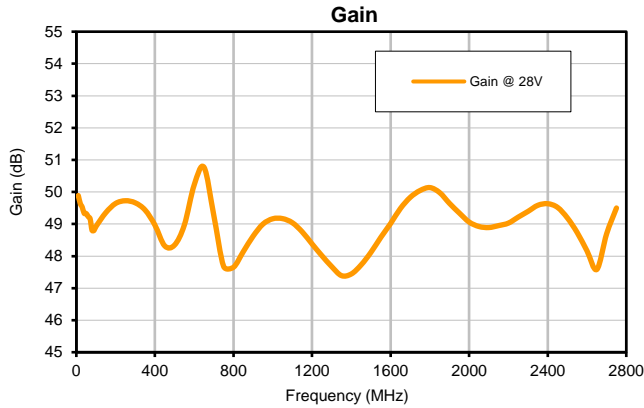

Outline Dimensions

BT2119

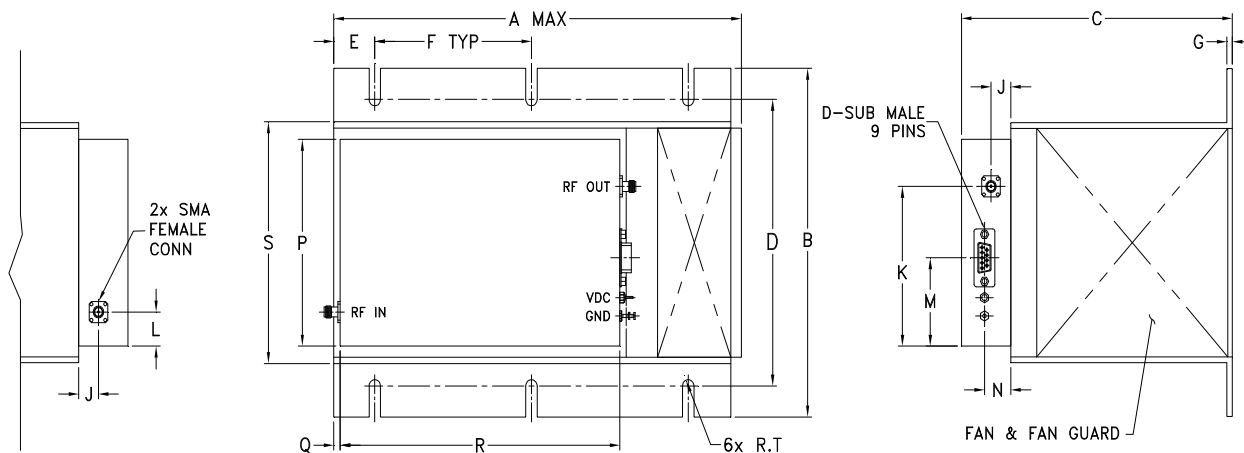

MOUNTING INFORMATION FOR MODELS WITHOUT HEATSINK.

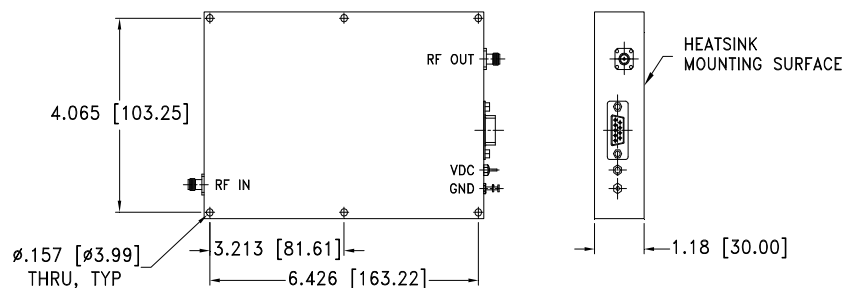

CASE#	A	B	C	D	E	F	G	H	J	K	L	M	N
BT2119	9.85 (250.19)	7.3 (185.42)	6.5 (165.10)	6.00 (152.40)	.98 (24.89)	3.75 (95.25)	.13 (3.30)	-	.47 (12.00)	3.34 (84.80)	.71 (18.00)	1.85 (47.00)	.63 (16.00)

CASE#	P	Q	R	S	T	WT, GRAM	WT WITHOUT HEATSINK, GRAM
BT2119	4.33 (110.00)	.2 (5.08)	6.69 (170.00)	5.1 (129.54)	.136 (3.45)	4565	880

Dimensions in inches (mm). Tolerances: 1 Pl. + .1; 2 Pl. + .03; 3 Pl. + .015

Notes:

- Case material: Aluminum alloy.
- Finish:
For RoHS Case Styles: Clear Chemical conversion coating, non-chrome or trivalent chrome based.
- Heatsink finish: Black anodize.
- Refer to the individual model data sheet for the type of connectors available.
- Recommended screws for mounting model without heat sink on 3/32" thick sheet: #6-32, 1.50" Length.
- Shape of connector flange may vary.



P.O. Box 350166, Brooklyn, New York 11235-0003 (718) 934-4500 Fax (718) 332-4661 For detailed performance specs & shopping online see Mini-Circuits web site



The Design Engineers Search Engine Provides ACTUAL Data Instantly From MINI-CIRCUITS At: www.minicircuits.com

RF/IF MICROWAVE COMPONENTS



All Mini-Circuits products are manufactured under exacting quality assurance and control standards, and are capable of meeting published specifications after being subjected to any or all of the following physical and environmental test.

Specification	Test/Inspection Condition	Reference/Spec
Operating Temperature	-20° to 45°C Ambient Environment	Individual Model Data Sheet
Storage Temperature	-55° to 100° C Ambient Environment	Individual Model Data Sheet
Stabilization Bake	(non-operating) 125°C, 24 hours	- - -
Burn-in at Elevated Temp.	(DC on) 160 hours at 60° C base plate Temperature	MIL-STD-202, Method 108
Thermal Shock	-55° to 100°C, 5 cycles	MIL-STD-202, Method 107, Condition A, except 100°C