



COAXIAL SOLID-STATE

High Power Amplifier

ZHL-2425-250+ ZHL-2425-250X+

50Ω 250W 2.4 to 2.5 GHz MCX & N-Type

THE BIG DEAL

- High output power, 300W
- 2.4 to 2.5GHz ISM band
- Suitable for CW and pulsed signals
- High gain, 42 dB typical
- High efficiency, 60%
- High ruggedness
- Built-in monitoring and protection for temperature, current forward and reflected power
- User friendly I2C control interface



Generic photo used for illustration purposes only

Model No.	ZHL-2425-250+	ZHL-2425-250X+
Case Style	VU3673	VU3193
Connectors	MCX & N-Type	

+RoHS Compliant
The +Suffix identifies RoHS Compliance.
See our website for methodologies and qualifications

PRODUCT OVERVIEW

The ZHL-2425-250X+ is a new generation solid state connectorized high-power amplifier module which can be used in a wide range of industrial, scientific and medical (ISM) applications in the 2400-2500 MHz ISM band. The ZHL-2425-250X+ provides many advantages over traditional magnetrons, such as longer lifespan, accurate frequency tuning, better frequency stability, precise control of output power, and lower power supply voltage. This rugged amplifier is capable of amplifying signals (CW & pulsed) from 1W to 300W output power with built-in monitoring and protection for temperature, current, supply voltage, forward power, and reverse power.

The amplifier has internal shutdown circuitry and integrated protection functions for added reliability under difficult operating conditions, making it virtually impossible to destroy both in single and multi-channel systems. The basic amplifier can be controlled externally with a few logic inputs or through a user friendly I2C control interface to monitor forward and reflected power to support dynamic load analysis, temperature, current, shutdown alarms, enabling the PA, and for resetting protection alarms. For advanced mode, users may consult the factory for more in-depth amplifier control commands, access to FWD/REFL power coefficients, and protection overrides.

KEY FEATURES

Feature	Advantages
High CW Power	Supports high power applications for a wide range of industrial, scientific and medical applications in the 2400 – 2500 MHz ISM frequency band. Power can be regulated accurately from 1W up to 300W (~P3dB, @+25C).
High Gain	A typical gain of 42 dB allows the ZHL-2425-250+ to be driven to full output power with commercially available integrated signal generators with a 14dBm output signal.
High Efficiency	The ZHL-2425-250+ uses high efficiency state of the art LDMOS technology. This combined with adaptive frequency control enables a high efficiency of typically 60% in most applications.
Built-in protection	The amplifier has built-in monitoring and protection for temperature, current, voltage, forward power, reverse power, and internal shutdown circuitry for added reliability under difficult operating conditions. When the prestored limits shown in the protection limits table are exceeded the amplifier will shut down.
Ruggedness	The amplifier has excellent reverse isolation and ruggedness with an onboard circulator. Reverse power is monitored, and the amplifier is shut down when the reverse power exceeds the prestored limits shown in the protection limits table.
Forward & Reverse Power detection	The amplifier features integrated couplers and detectors for Forward (FWD) and Reflected (REFL) power detection. FWD and REFL power detection supports accurate RF power measurements as well as dynamic load analysis and can be used to control or shut-off the amplifier by using the internal monitoring or an external controller.
Easy interfacing	Easy access to the amplifiers analog and digital (I2C) data, enabling dynamic ISM applications with either single or multiple modules to be controlled.
Small and lightweight	With a small footprint (55.9mm x 171.5mm x 15mm) the lightweight (0.29 kg) modular design is flexible for single or multiple amplifier system integration.
Cooling	The amplifier can either be air or water cooled. Mounting screw holes are available on the amplifier.
Low voltage	The ZHL-2425-250+ is powered by a low voltage 32V supply.



COAXIAL SOLID-STATE

High Power Amplifier

ZHL-2425-250+
ZHL-2425-250X+

50Ω 250W 2.4 to 2.5 GHz MCX & N-Type

ELECTRICAL SPECIFICATIONS AT +25°C, 32V, 50Ω SYSTEM, 3.3V LOGIC LEVELS

Parameter	Symbol	Conditions	Min.	Typ.	Max.	Units
Frequency Range	f		2400		2500	MHz
Input Power	P _{in}	f=2400 MHz to 2500 MHz	—	12.5	15	dBm
Output Power	P _{OUT}	@P _{IN_Typ.} , f=2400 MHz to 2500 MHz	250	300	—	Watts
			54	54.8	—	dBm
Power Gain	G _P	@P _{IN_Typ.} , f=2400 MHz to 2500 MHz	40	42	—	dB
Gain Flatness	G _{FLAT}	@P _{IN_Typ.} , f=2400 MHz to 2500 MHz	—	0.5	1.0	dB
Efficiency	η	@P _{IN_Typ.} , f=2400 MHz to 2500 MHz	52	60	—	
Input VSWR	I_VSWR	@P _{IN_Typ.} , f=2400 MHz to 2500 MHz	—	1.9:1	2.3:1	
Operating Voltage	V _{DC}	@P _{IN_Typ.} , f=2400 MHz to 2500 MHz	31.5	32	32.5	V
Supply Current	I _{DC}	@P _{IN_Typ.} , f=2400 MHz to 2500 MHz	—	16	18	A
Temperature Sense (based on analog output)	T _{sense}	T _{sense} = (-72.183 x TEMP_AOUT) + 187.04 (TEMP_AOUT is the analog voltage on pin 8 of the conn. J2, temperature can also be read thru I2C)				°C
Supply Current Typical (based on analog output)	I _{current}	I _{current} = (6.21 x ISENSE_AOUT) - 0.01 (ISENSE_AOUT is the analog voltage on pin 6 of the conn. J2, current can also be read thru I2C)				A
PA On / Off	—	Enable (TTL low) / Disable (TTL high) on Pin 5 of Connector J2				

PROTECTION LIMITS¹

Parameter	Symbol	Min.	Max.	Units
Temperature Sense ^{3,4}	T _{sense}	0	65	°C
Reverse Power	REFL_POWER_A	—	200	Watts
			53	dBm
Voltage Supply	VDS_SENSE_A	24	40	V
Current Supply	ISENSE_A	—	18	A

MAXIMUM RATINGS²

Parameter	Ratings
Operating Temperature ^{3,4}	0°C to +65°C
Storage Temperature	-20°C to +85°C
DC Voltage	40V
Input RF Power (no damage)	+15 dBm
Power (reflected or other RF source) into the RF output conn. (no damage)	200W
Fan Supply Current (only on model with heatsink)	3A

- When the prestored limits are exceeded, the amplifier will shut-down and remain disabled until a reset command is sent thru the I2C interface or by applying a logic high level to pin 3 of connector J2.
- Specifications apply to CW signals only. Permanent damage may occur if any of these limits are exceeded.
- This is the sensed operating temperature calculated from the analog output or read thru I2C.
- There is an offset from the temperature measured at the temp. sense location to the amplifier pallet base of approximately +10°C. I.e. When the internal sensed temperature read thru I2C from the PA is 65°C then the temperature at the base of the pallet is approximately +75°C.

HEATSINK REQUIREMENTS

Depending on the end system design or architecture either water cooling or air cooling must be used to cool the ZHL-2425-250X+ power amplifier module. In order to provide the user with the flexibility to decide on the cooling type, Mini-Circuits provides the ZHL-2425-250X+ without a heat sink and the user decides what type of cooling they want to use. It is absolutely critical that the amplifier is always mounted to a heatsink where the airflow of a fan on an air-cooled heat sink or the water temperature and flow rate of a water-cooled heatsink is set to keep the amplifier below 65degC at full RF power when operating, otherwise the amplifier will get too warm and the built-in protection alarms will be activated and the power amplifier will shut itself down. The Application note, [AN-60-110](#), describes how to mount the ZHL-245-250X+ to a Mini-Circuits air cooled heatsink ([HSK-2425-250+](#)). This is a heat sink that is designed specifically for the [ZHL-2425-250X+](#) amplifier and is also available through the Mini-Circuits website. The heat sink version of the amplifier ([ZHL-2425-250+](#)) is an assembly that includes the heatsink, fan, and fan speed controller. The fan speed controller modulates the fan speed based on the temperature of the heat sink to reduce noise and power consumption when operating in a standby or lower power mode.





APPLICATION

The ZHL-2425-250X+ amplifier module can be used as a building block in any single or multi-channel system for high power RF Energy applications such as:

- Industrial heating
- Materials processing
- Food processing (heating, tempering, and pasteurization)
- Microwave-assisted chemistry
- Plasma generation
- Plasma surface treatment
- Disinfection
- Chemistry
- RF-excited lasers
- Medical (heating, hyperthermia, and ablation)
- Semiconductor RF generators

BLOCK DIAGRAM

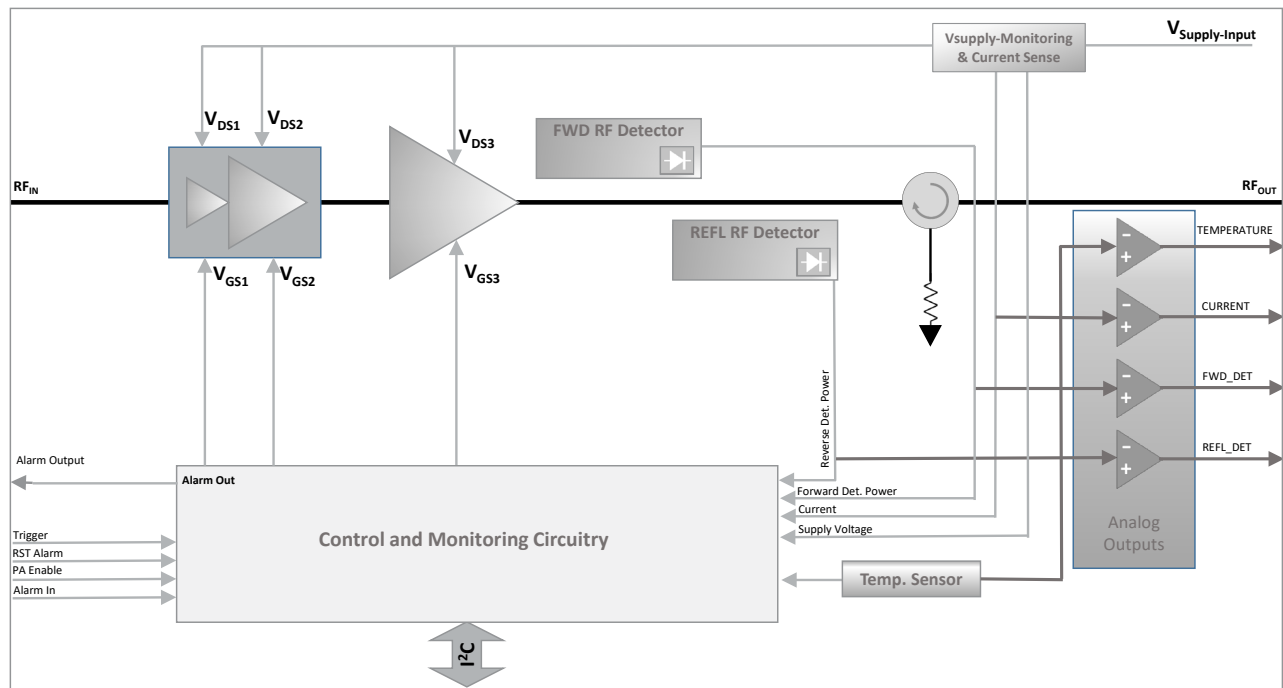

APPLICATION OVERVIEW

The ZHL-2425-250X+ can easily be driven by most standard signal generators, when connected to a DC power supply and mounted to a heat sink. The module is ready to deliver RF power to any applicator, i.e., a "device" to contain and/or apply the RF energy. The use of the latest generation solid state devices guarantees high efficiency, long lifetime, fully controllable and stable output power in a compact module outline. The amplifier has built-in monitoring and protection for temperature, current, supply voltage, forward power, reverse power, and internal shutdown circuitry for added reliability under difficult operating conditions, making it virtually impossible to destroy in single and multi-channel systems due to the integrated circulator and protection functions. When the prestored limits shown in the protection limits table are exceeded the amplifier will shut down and remain disabled until an alarm reset is sent either by an I2C command or a TTL high applied to pin 3 of the multi-pin connector J2. For advanced mode, users may consult the factory for more in-depth amplifier control commands, access to FWD/REFL power coefficients, and protection overrides. The ZHL-2425-250X+ can operate in both CW and PWM mode. When operating in PWM mode a minimum of four 1000uF or two 2400uF electrolytic capacitors should be used and located on the DC power supply line close to the amplifier supply terminals in parallel from the +32V supply to ground. These capacitors will increase reliability of the amplifier in PWM mode and improve the RF waveform overshoot and ripple in the pulse. Increasing the quantity of the electrolytic capacitors (4-8x 1000uF or 2-4x 2400uF) in parallel will extend the lifetime of these electrolytic capacitors.



There are two operation modes supported by the ZHL-2425-250X+

1. STANDARD OPERATION MODE (STDOM)

- PA Enable/Disable
- Built-in protection features enabled
- Ability to reset protection shutdown via I2C command or logic high on pin3
- Access to analog outputs for temperature, forward power, reverse power, and current that can be correlated to output power
- Access through the I2C to read Temperature (° C), forward power (dBm or W), reverse power (dBm or W), supply voltage (V), and current (A)
- The amplifiers are shipped from the factory in this mode.

2. ADVANCED OPERATION MODE (ADVOM)

- All of the "standard operation mode" features are available
- Access to the prestored protection limits for shutdown
- Access to enable/disable internal protection shutdown or change prestored internal shutdown limits (amplifier warranty is no longer valid in this situation).
- Access to all coefficients and digital data for forward detected power, reverse detected power, temperature, supply voltage, and current
- With either mode the external analog, digital signals, and control logic can optimize the RF vector (frequency, power, and time) depending on the application's needs in real time.

CONTROL INTERFACE PIN OUT AND FUNCTIONALITY (J2 MULTI-PIN CONNECTOR, 3.3V LOGIC LEVELS)

Pin Number	Label	Type	Functionality and Control
1	TRIG_IN		Used during pulse mode operation.
2	REFL_AOUT		Analog voltage (0 to 3.3V) that can be correlated to the level of the reflected power or power incident at the J5 connector.
3	RST_ALARM		Reset Alarm – Internal protection shutdown can be reset thru the I2C communication or applying a TTL high to this pin.
4	FWD_AOUT		Analog voltage (0 to 3.3V) that can be correlated to the level of the forward output power.
5	PA_ENABLE		Enable (TTL low) / Disable (TTL high). Normally low, enabled, and can be disabled when a TTL high is applied.
6	ISENSE_AOUT		Analog voltage (0 to 3.3V) that correlates to the amplifier current level
7	ALARM_IN		This can be used by a system controller or another ZHL-2425-250X+ amplifier to send an alarm input to shut down the amplifier. This pin is normally low and can be set to a TTL high to shut-down the amplifier.
8	TEMP_AOUT		Analog voltage (0 to 3.3V) that can be correlated to the temperature. See equation in electrical specification table
9	Do Not Connect		Reserved pin for manufacturer
10	GND		Ground
11	ALARM_OUT		When the protection limits are exceeded and the amplifier is shutdown, this pin will go from normally TTL low to TTL high. This output can be used by an external controller to shut down the system or can be connected to other ZHL-2425-250X+ amplifiers ALARM_IN pins to shut them down.
12	GND		Ground
13	SCL		I2C control
14	GND		Ground
15	SDA		I2C control
16	GND		Ground
17	Do Not Connect		Reserved pin for manufacturer
18	Do Not Connect		Reserved pin for manufacturer
19	Do Not Connect		Reserved pin for manufacturer
20	Do Not Connect		Reserved pin for manufacturer

**I2C CONTROL AND BASIC COMMANDS (FIRMWARE VERSION A5)**

The ZHL-2425-250X+ supports the I2C bus communication standard.

Up to 8 units can be connected on the same I2C clock and data lines with the same base address and different *unit addresses* through 3 address bits (A2-A0).

Up to 8 units can be connected on the same I2C clock and data lines with the same base address and different unit addresses through 3 address bits (A2-A0). All amplifiers from the factory are set to local unit address of 0 by default. See example 1 to set the individual unit address.

The I2C 8 bits *control address* is composed as follows:

A base address of binary 1010 and 3 unit-address bits + a bit indicating a read or write operation: 1010 [A2][A1][A0][R/W];

the default *control address* hence evaluates to 0xA0 for a write operation. A2-A0 represents the address bits where logic high = 1 and logic low = 0. For an I2C bus write operation, the last bit W=Write must be 0; For a read operation, the last bit R=Read must be 1.

CW AND PULSE MODE OPERATION:

The amplifier can be operated in CW or pulse mode. In order to obtain the correct results from reading ADC values with registers 101(ADC_FWD), 103(ADC_REFL), 105(ADC_Current), 107 (ADC_VDS), and reading power, current, and voltage from registers 245(FWD_dBm), 247 (REFL_dBm), 249 (Current_Amp), 251 (VDS_Volt) through I2C from the ZHL-2425-250X+ the register 132 (ADC_Trigger_Mode) must be set correctly for each mode. The register 132 should be set to 0 (default) for CW signal mode and set to >0 for PWM mode.

For PWM mode, Pin 1, TRIG_IN, must be used to trigger the internal measurement during the pulse. When the ADC_Trigger_Mode, register 132, is set to >1 and a trigger is issued to Pin 1 on the ZHL-2425-250X+ the firmware will wait for the delay time set in register 130 (delay_after_trigger) and then record ADC values correlating to forward power, reflected power, current, and supply voltage in a total time of approximately 32μs. To avoid any error from ripple in the beginning of the pulse the delay after trigger has been set to a default minimum of 30μs. Therefore, the pulse width should not be <62μs, this is with the average count (register 134) set to 1 and the delay after trigger (register 130) set to the default of 30μs. The Pulse Width must be greater than DelayAfterTrigger(30μs minimum) +(32 x Avg_Count) μs. The results from reading registers 101, 103, 105, 107, 245, 247, 249, and 251 will be the values recorded after the last external trigger.

For CW the ADC_Trigger_Mode, register 132, should be set to 0. No external trigger is required and average count and delay after trigger is not used.

I2C REGISTER ADDRESSES (REQUEST CODE) LOWER THAN 140:

Sending data to the device for that register range will always be by sending the register address followed by 2 bytes High and Low. Reading data will always be 2 bytes of reading High then Low bytes successively (big endian). Data type integer.

Example 1: Set the individual unit local address to 1 - options for local address are 0 to 7 - default local address is 0

```
1. I2C_Start
2. I2C_Write (I2C_Control_Address_W) //control address - Write
3. I2C_Write (126) //Address register to set the local address
4. I2C_Write (0) //write high byte with value 0x00
5. I2C_Write (1) //write low byte with value 0x01
6. I2C_Stop // the new local address will be affected after next reset of the device
```

Example 2: Reset Alarm after internal protection shutdown event.

```
1. I2C_Start
2. I2C_Write (I2C_Control_Address_W) //control address - Write
3. I2C_Write (102) //Address register to set the reset code
4. I2C_Write (1) //write high byte with value 0x01
5. I2C_Write (1) //write low byte with value 0x01
6. I2C_Stop // the amplifier logic will reset the unit
```

Example 3: Read ADC_FWD value (ADC value correlating to forward detected power).

```
1. I2C_Start
2. I2C_Write (I2C_Control_Address_W) //control address - Write
3. I2C_Write (101) //Address register to get the ADC_FWD value
4. I2C_Stop
5. I2C_Start
6. I2C_Write (I2C_Control_Address_R) //Control Address - Read
7. ByteH=I2C_Read()
8. ByteL=I2C_Read()
9. I2C_Stop
```



FOR I2C REGISTER ADDRESSES (REQUEST CODE) 140 AND ABOVE:

Sending data to the device for this register range will always be by sending register address followed by 4 bytes of data High to low. Reading data will always be 4 bytes of data High to Low (big endian). **IMPORTANT:** Data should be interpreted as 32 bits float.

Example 4: Set the CAL frequency (i.e., the currently used frequency) for the frequency dependent data that will be read out later i.e., FWD_dBm, REFL_dBm. Parameters like Current_Amp, VDS_V, TFinal_deg do not depend on the current frequency used.

Set the I2CR_Set_CAL_freq to 2450 (Frequency is in MHz; 32bits float)

```

1. I2C_Start
2. I2C_Write (I2C_Control_Address_W) //control address - Write
3. I2C_Write (240) //Address register to set the cal_frequency value
4. I2C_Write (69) // Byte4
5. I2C_Write (25) // Byte3
6. I2C_Write (32) // Byte2
7. I2C_Write (0) // Byte1
8. I2C_Stop

```

Example 5: Get the output power in dBm at the frequency set in the previous example.

Get the I2CR_Get_FWD_dBm :

```

1. I2C_Start
2. I2C_Write (I2C_Control_Address_W) //control address - Write
3. I2C_Write (245) //Address register to get the FWD_dBm value
4. I2C_Stop
5. I2C_Start
6. I2C_Write (I2C_Control_Address_R) //Control Address - Read
7. Byte4=I2C_Read()
8. Byte3=I2C_Read()
9. Byte2=I2C_Read()
10. Byte1=I2C_Read()
11. I2C_Stop

```



COAXIAL SOLID-STATE

High Power Amplifier

ZHL-2425-250+
ZHL-2425-250X+

50Ω 250W 2.4 to 2.5 GHz MCX & N-Type

REGISTER TABLE:

Register #	Label	Function
98	Set_I2C_BaseAddress	Set base address, valid values are: 0x90, 0xA0, 0xB0
99	Get_I2C_BaseAddress	Read base address
101	Read_ADC_FWD	Read the ADC value correlating to forward power.
102	I2C_RST_ALARM	Reset the alarm that caused a shutdown. DataByte_L=1 DataByteH=1
103	Read_ADC_REFL	Read the ADC value correlating to reflected or reverse.
105	Read_ADC_Current	Read the ADC value correlating to the DC current drawn by the PA.
107	Read_ADC_VDS	Read the ADC value correlating to the measured supply voltage.
111	Read_ADC_TFinal	Read the ADC value correlating to the temperature.
113	Get_FirmwareID	Read the current firmware ID
115	Get_FirmwareVersion	Read the current firmware version
119	Get_InternalAlarm_Cause	Read the internal alarm cause*
126	Set_I2C_LocalAddress	Set unit address bits [0-7]; requires unit reset to take effect
127	Get_I2C_LocalAddress	Read unit address
129	I2C_Get_AvgCount	Get Average count for reading ADCs when triggered.
130	I2C_Set_DelayAfterTrigger	For PWM operation, set delay after trigger before FWD_ADC, REFL_ADC, VDS_ADC, and Current_ADC values are read during the pulse and saved in firmware. Default set to 30µs.
131	I2C_Get_DelayAfterTrigger	For PWM operation, Read delay after trigger
132	Set_ADC_Trigger_Mode	Set 0 for "normal" reading during CW operation or positive number for Trigger Mode reading during PWM operation. (See para. CW and Pulse Mode Operation above)
133	Get_ADC_Trigger_Mode	
134	I2C_Set_AvgCount	For PWM operation, Set Average count for reading ADCs when triggered. Min. Average Count is 1 (default), Max. is 50.
240	I2CR_Set_CAL_freq	Set freq. in MHz for the data to be read from in registers 241, 245, 247
241	I2CR_Get_CAL_freq	Read Cal frequency in MHz
245	I2CR_Get_FWD_dBm	Read forward power in dBm (4 bytes float)
247	I2CR_Get_REFL_dBm	Read reflect power in dBm (4 bytes float)
249	I2CR_Get_Current_Amp	Read amplifier current in Amps (4 bytes float)
251	I2CR_Get_VDS_Volt	Read Vsupply in volts (4 bytes float)
253	I2CR_Get_TFinal_deg	Read temperature in °C (4 bytes float)

*Internal Alarm Cause:

2 bytes value, each bit represents and alarm cause as follows. (bits 8, 9, 12,13,14, and 15 are reserved)

bit0: Reflected Power > Upper Limit

bit1: Reflected Power < Lower Limit ¹

bit2: Forward Power > Upper Limit ¹

bit3: Forward Power < Lower Limit ¹

bit4: Current > Upper Limit

bit5: Current < Lower Limit ¹

bit6: VSupply > Upper Limit

bit7: Vsupply < Lower Limit

bit10: Temperature > Upper Limit

bit11: Temperature < Lower Limit

1. There is no protection limit set, so there should never be an internal alarm for these parameters.





COAXIAL SOLID-STATE

High Power Amplifier

ZHL-2425-250+ ZHL-2425-250X+

50Ω 250W 2.4 to 2.5 GHz MCX & N-Type

OUTLINE DRAWING ZHL-2425-250X+

*M3 SHCS (DIN 912, ISO 21269)
Recommended.
For Mounting, Torque to max.
1.5Nm (13lbf in)

Mounting Hole Locations
(Shield Cover Requires Temporary Removal to Install Mounting Screws)

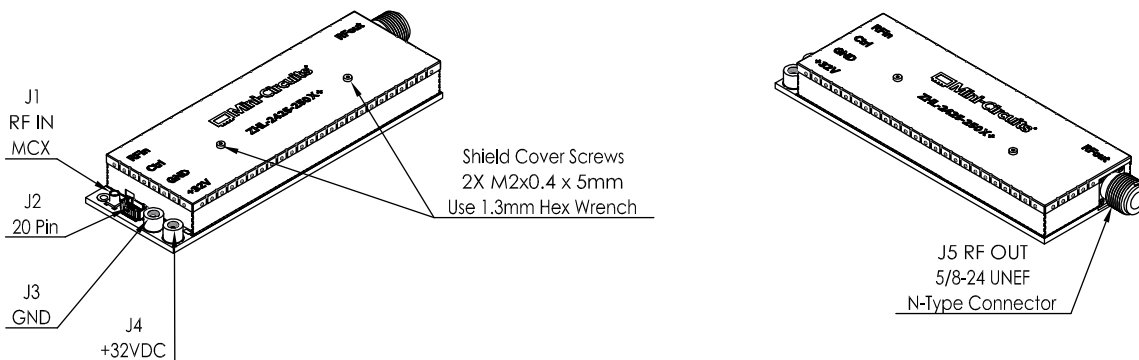
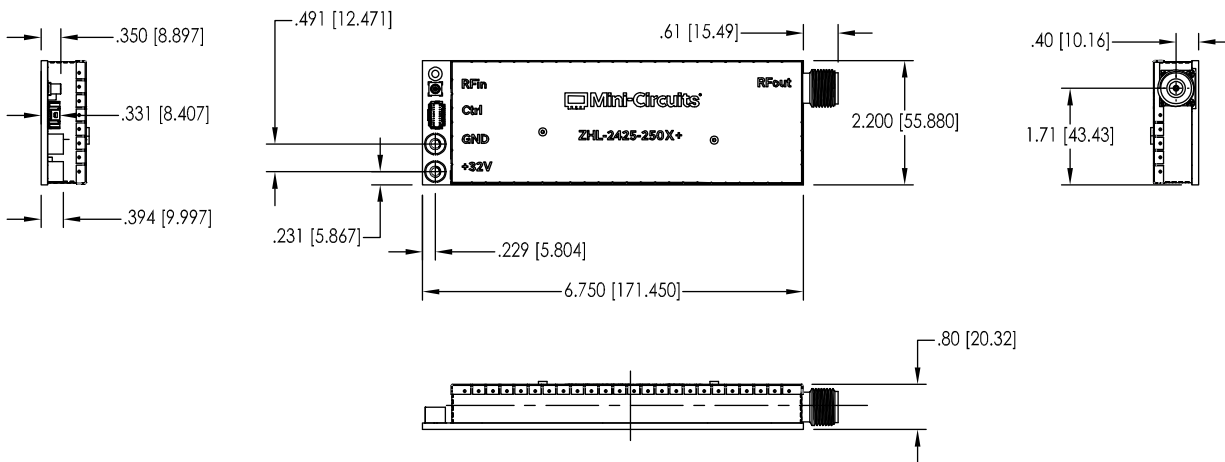
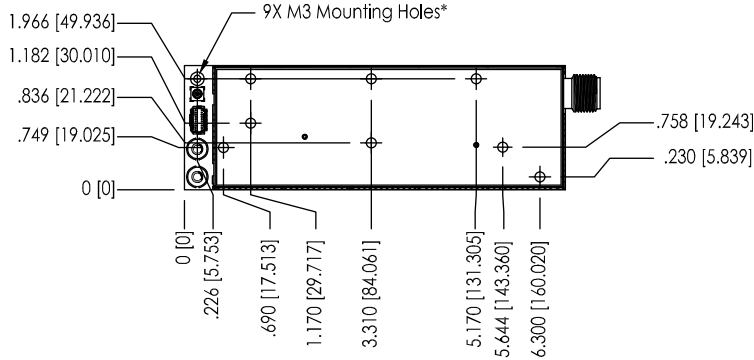

Weight: 290 grams;
Dimensions are in inches [mm]. Tolerances: 2 PL ±.01 [0.254]; 3 PL ± .005 [0.127]





COAXIAL SOLID-STATE

High Power Amplifier

ZHL-2425-250+ ZHL-2425-250X+

Mini-Circuits

50Ω 250W 2.4 to 2.5 GHz MCX & N-Type

OUTLINE DRAWING ZHL-2425-250+

PRODUCT MARKING

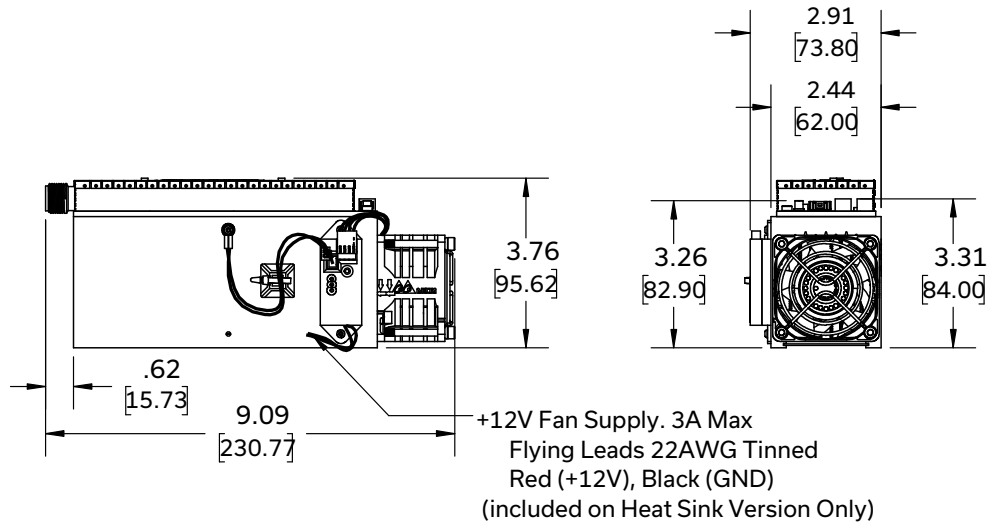
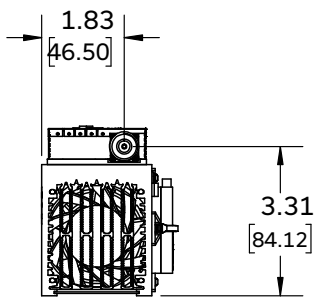
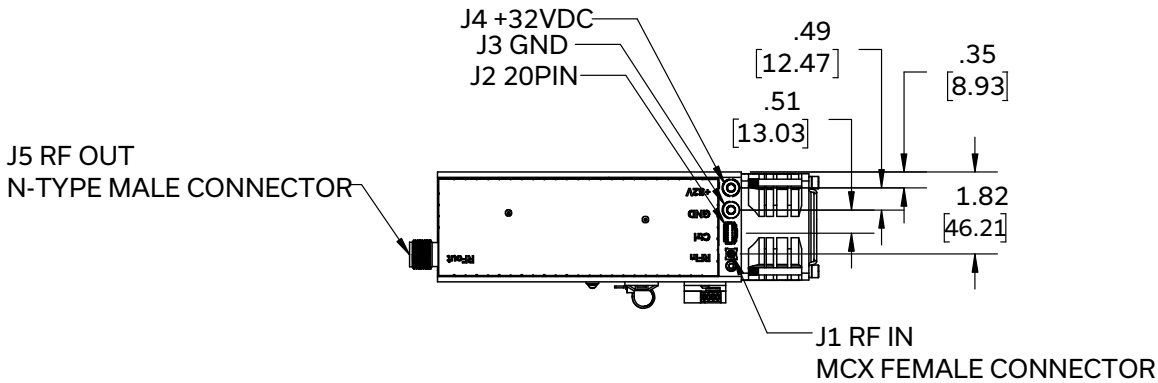
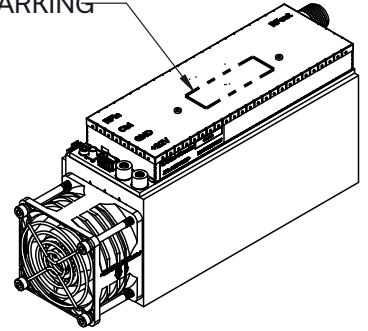
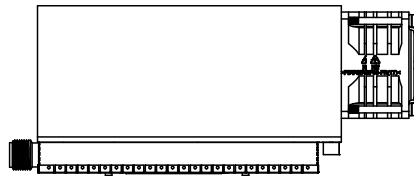

WEIGHT: 1,150 GRAMS

DIMENSIONS ARE IN INCHES [mm]. TOLERANCES: 1 PL. ±0.05INCH 2 PL. ±0.03INCH, 3 PL. ±0.015INCH





COAXIAL SOLID-STATE

High Power Amplifier

ZHL-2425-250+ ZHL-2425-250X+

50Ω 250W 2.4 to 2.5 GHz MCX & N-Type

TYPICAL PERFORMANCE DATA (32V, 50Ω SYSTEM)

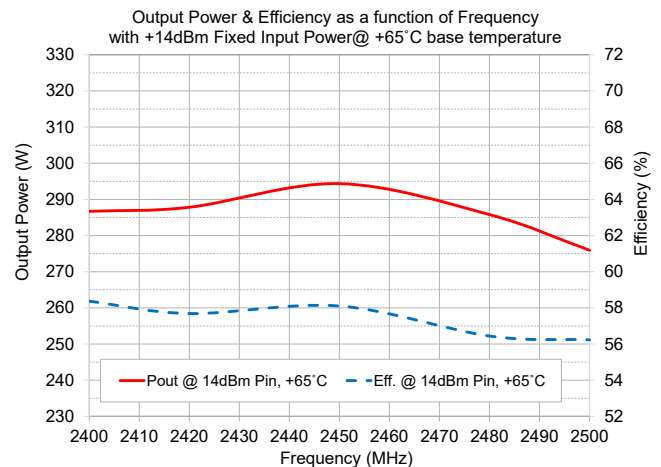
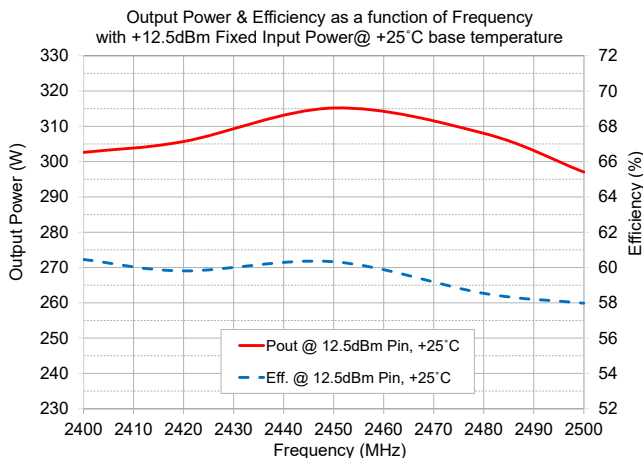
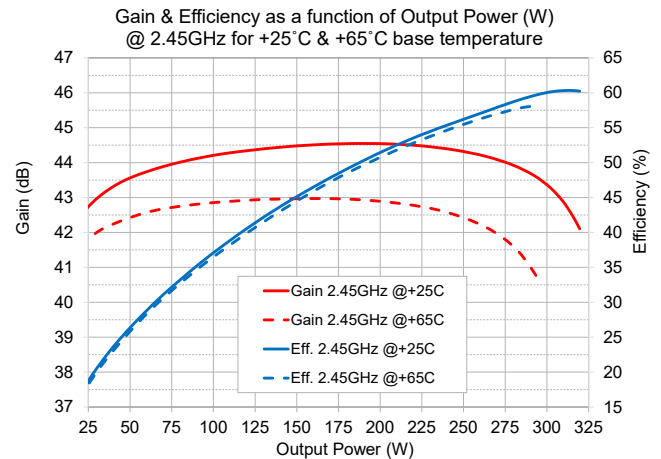
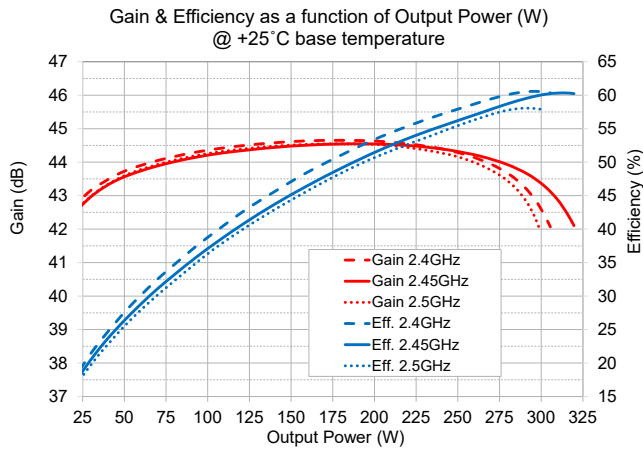
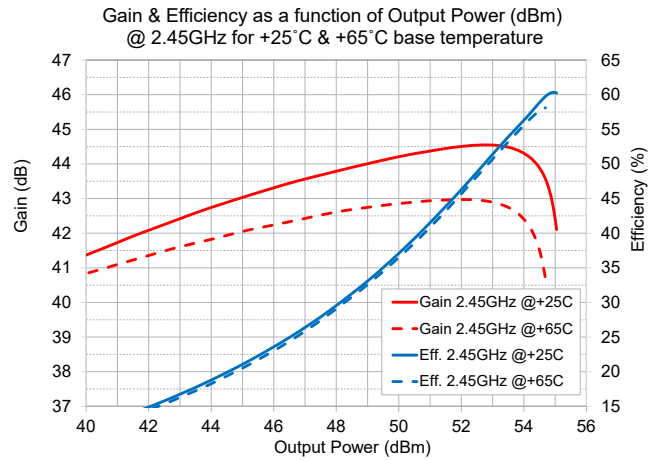
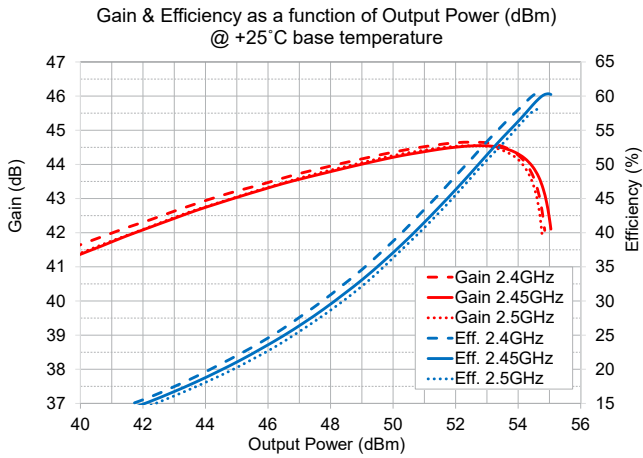



TYPICAL PERFORMANCE DATA (32V, 50Ω SYSTEM)

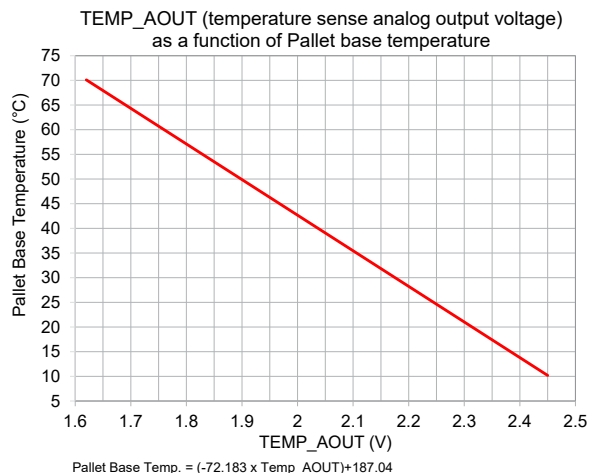
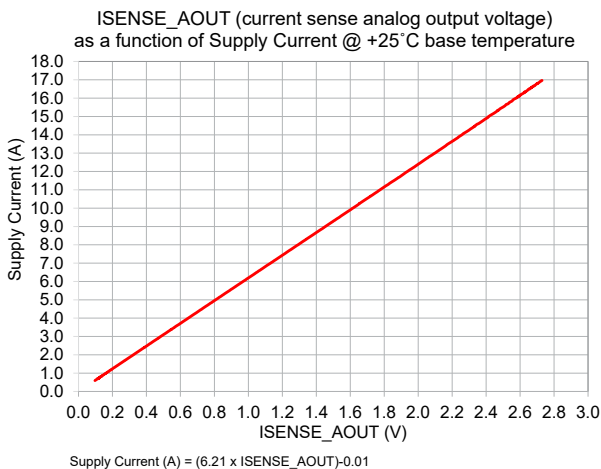
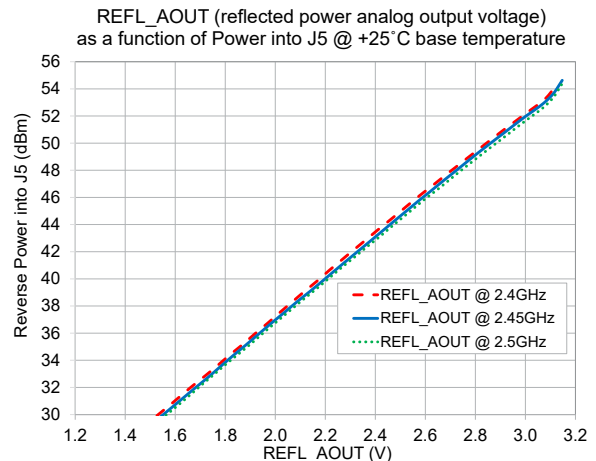
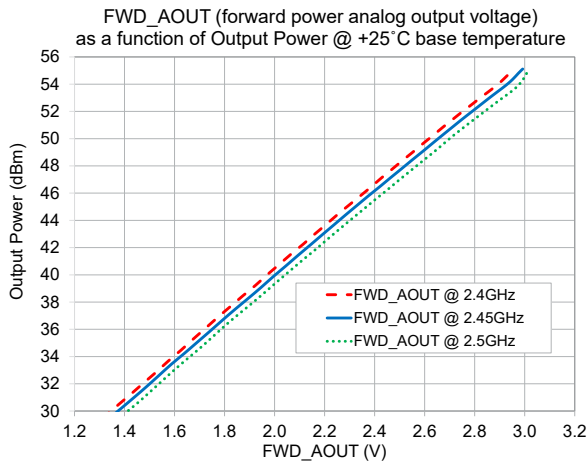
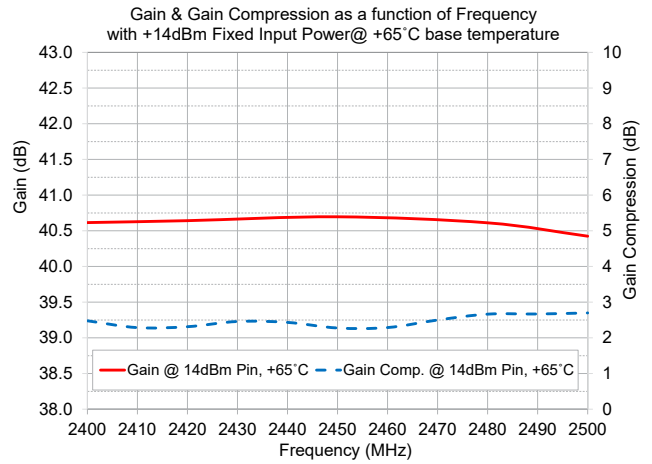
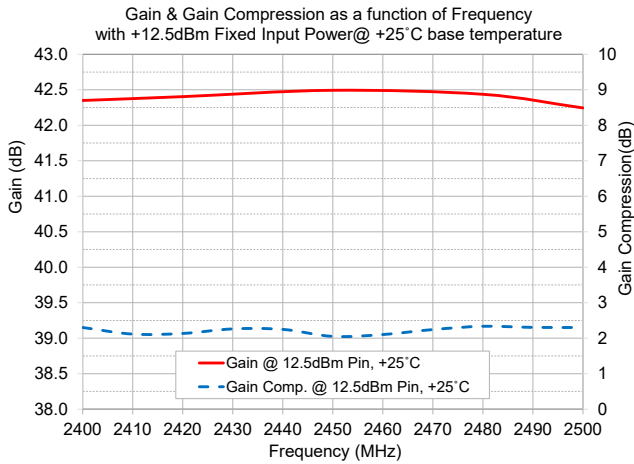



COAXIAL SOLID-STATE





High Power Amplifier

ZHL-2425-250+
ZHL-2425-250X+

Mini-Circuits

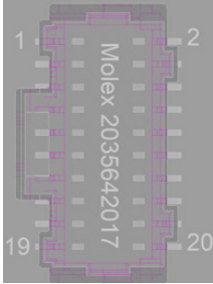
50Ω 250W 2.4 to 2.5 GHz MCX & N-Type

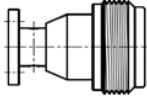
AMPLIFIER INTERFACES AND SUGGESTED MATING HARDWARE*

	<p>J1 - MCX Connector Jack, Female Socket 50 Ohm (Molex P/N 73415-1692)</p> <p>Mating 12" SMA Male to MCX Right Angle Cable Mini-Circuits P/Ns: FL086-12SMMCR+, 086-12SMMCR+</p>
	<p>J2 - Control Connector, 20 Pin (Molex 203564-2017)</p> <p>Mating connector shell, Molex 501189-2010, and cables with pre-crimped leads, Molex 79758-1018 or 79758-1019.</p>
	<p>J3 - Ground Conn., M5 J4 - +32V Supply Conn., M5</p> <p>Tightening Torque 1.7 N-m (15 in-lbs) with max. of 2.15 N-m (19 in-lbs)</p> <p>Mating M5 screw (Mcmaster P/N 92095A308) Belville washer (Mcmaster P/N 90895A027) Ring Terminal (Mcmaster P/N7113K29)</p>
	<p>J5 Output connector N-type female Recommended Torque for N-type connector mate is 1.36 N-m (12 in-lbs)</p>
	<p>J6 - +12V Fan Supply. 3A Max Flying Leads 22 AWG Tinned Red (+12V), Black (GND) (Included on Heat Sink Version Only)</p>

*Mating hardware not included with amplifier. Similar mating hardware available from other manufactures.



COAXIAL SOLID-STATE

Amplifier Evaluation Kit

ZHK-2425-250+

50Ω 250W 2.4 to 2.5 GHz MCX & N-Type

PRODUCT OVERVIEW

The amplifier and the system controller are the fundamental building blocks of microwave generator subsystems. The ZHK-2425-250+ is a kit containing one of each of these core building blocks and the interconnect required to jumpstart product evaluation for the 250W microwave generator application. Higher output powers are readily achievable through power combining with up to 8 amplifiers per system controller using Mini-Circuits splitter (ex. SPL-2G42G50W4+) and combiner (ex. COM-2G42G51K0+) products. Contact our worldwide technical support team at apps@minicircuits.com for questions related to your application.

KIT COMPONENTS

Ref.	Image	Description	Mini-Circuits P/N
PA		250W, 2.45GHz PA with Heatsink, Fan, and Speed Controller	ZHL-2425-250+
SG		Signal Source and controller Kit 2.45GHz (Includes Interconnects I2, I7, and I8. See ISC-2425-25+ datasheet for details)	ISC-2425-25+
I1		12" SMA Male to MCX RF Cable ISC to ZHL connection	FL086-12SMMCR+
I5		12" Hand-Flex, 300W, N-Type Interconnect Cable	141-12NM-300W+
I3, I4		3FT 12AWG Hookup Wire Red & Black w/ terminal mounting hardware 2 ea M5 Screw and Belleville Washer: McMaster 92095A308, 90895A027 Hex Driver for M5 Screw: McMaster 7289A14 2ea Insulated Ring and Spade Terminals: McMaster 7113K29, 69145K218	N/A

ADDITIONAL TOOLS REQUIRED FOR EVALUATION

Ref.	Description	Reference Part Number ¹
PC	Windows PC or Raspberry Pi, with ISC-2425-25+ GUI	See Software Download Page
32V	Power Supply, 32V, 16A+. (External Capacitor Required for PWM Evaluation See Electrical Specifications Table)	Keysight E36155A TDK-Lambda Z36-24-L-U
+12V	Power Supply, 12V, 3A+	Mini-Circuits AC/DC-12-3W
+5.5V	Power Supply, 5.5V, 1A+	Most Lab Bench Power Supplies
ATT	Attenuator or Termination 50Ω, 300W, 40dB	Bird 300-WA-FFN
For I3 & I4	Crimper, 10-12 AWG (Yellow) Insulated Terminals	Klein Tools 3005CR
For I3 & I4	Wire Stripper Tool 12AWG	Klein Tools 1011
I6	Terminal Block and/or Hookup Wires to +12V supply	McMaster 8320N61
I9	Hookup Wires, +5.5V supply to terminal block	Solid or Stranded Wire (AWG 28-14)
PS	USB Power Sensor (Optional)	Mini-Circuits PWR-8P-RC
-	Torque Wrench SMA	Mini-Circuits TRQ-516-09
-	Torque Wrench N-Type	Mini-Circuits TRQ-N20-8

1. All reference part numbers are commercial off the shelf items that satisfy the basic requirements of the test setup. These part numbers are provided for reference only and Mini-Circuits does not guarantee the availability of these parts nor the applicability of these parts to any specific application.

APPLICATION CIRCUIT 250W GENERATOR TEST SETUP

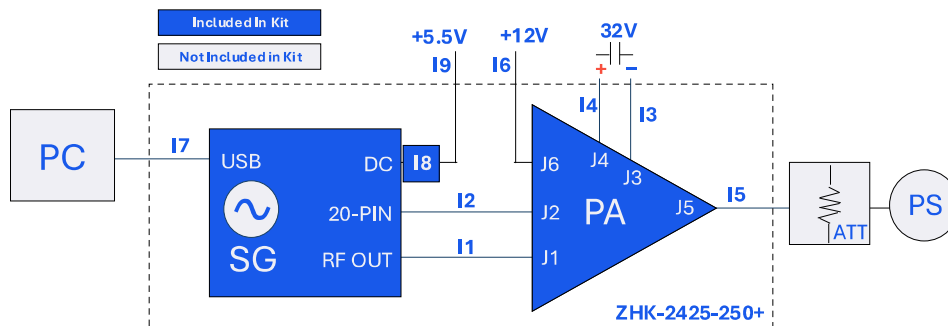



COAXIAL SOLID-STATE

High Power Amplifier

ZHL-2425-250+
ZHL-2425-250X+

Mini-Circuits

50Ω 250W 2.4 to 2.5 GHz MCX & N-Type

SAFETY INSTRUCTIONS.

WARNING: FAILURE TO FOLLOW THESE INSTRUCTIONS MAY RESULT IN BODILY INJURY, DEATH, OR PROPERTY DAMAGE.
For your own safety, this section provides instructions for avoiding potential dangers when using this product.

QUALIFIED PERSONNEL

This product should be operated by qualified personnel only. Qualified personnel are individuals who are familiar with the operation of the product and the hazards involved with such operation.

DAMAGED OR MISSING HARDWARE

Do not operate the product if there is physical damage or hardware is missing.

MAXIMUM RATINGS

The maximum ratings in this data sheet should never be exceeded. Stress above one or more maximum ratings may cause permanent damage to the product and may permanently and irreversibly affect the quality and reliability of the product, which may increase the risk of bodily injury, death, or property damage.

HAZARDOUS RF VOLTAGES

The RF voltages inside the product and on the center pin of the RF output connector can be hazardous. Contact with the internal components of the product or the center pin of the RF output connector may lead to burns or electrical shock. Disconnect power before removing the protective cover from the product. Note that removing the protective cover from the product will void the express warranty specified in Mini-Circuits Standard Terms.

To reduce the risks presented by these hazards:

1. never operate the product without its protective cover,
2. always connect the RF output connector to a load before the power source is applied to the product, and
3. always place the product in a non-operating condition before disconnecting or connecting the load to the RF output connector.

COOLING

RF Power amplifiers always need proper cooling. Failure to properly cool the product may increase the risk of bodily injury, death, or damage to property or the product.

Some products contain water cooling systems to help cool down the product. If this data sheet indicates that the product contains a water cooling system, proper waterflow as specified in this data sheet is required to keep the temperature of the product within the temperature range that is specified in this data sheet.

Some products also contain built-in protection circuitry designed to shut-off the amplifier at excessive high temperatures or at other excessive operating conditions. Even if this data sheet indicates that the product contains protective circuitry, such protective circuitry is not a substitute for proper handling in accordance with these instructions. Accordingly, do not rely on the protective circuitry to prevent injury or damage to product or the product.

MAINTENANCE CAUTION

Maintenance or repair of the product must only be performed by qualified personnel when the product is in a non-operating condition and disconnected from its power source. Note that performance of maintenance or repairs to the product will void the express warranty specified in Mini-Circuits Standard Terms.

ENVIRONMENTAL CONDITIONS

Unless otherwise stated in this data sheet, this product is designed to be operated under the environmental conditions set forth in this data sheet, as well as the following conditions:

- Indoor use only
- Temperature of 5°C to 40°C (non-condensing)

WARNING SIGNS

In addition to being qualified before operating the product, pay attention to all warning signs and danger symbols. Failure to heed warnings signs and danger symbols, or to follow their associated instructions, may result in bodily injury, death, or property damage.

NOTES

- A. Performance and quality attributes and conditions not expressly stated in this specification document are intended to be excluded and do not form a part of this specification document.
- B. Electrical specifications and performance data contained in this specification document are based on Mini-Circuit's applicable established test performance criteria and measurement instructions.
- C. The parts covered by this specification document are subject to Mini-Circuits standard limited warranty and terms and conditions (collectively, "Standard Terms"); Purchasers of this part are entitled to the rights and benefits contained therein. For a full statement of the standard terms and the exclusive rights and remedies thereunder, please visit Mini-Circuits' website at www.minicircuits.com/terms/viewterm.html



Typical Performance Data

Frequency (MHz)	Gain @ 12.5dBm Pin, +25°C (dB)	Gain Comp. @ 12.5dBm Pin, +25°C (dB)	Pout @ 12.5dBm Pin (dBm)	Pout @ 12.5dBm Pin, +25°C (W)	Eff. @ 12.5dBm Pin, +25°C (%)	IRL@ 12.5dBm Pin, +25°C (dB)
2400	42.35	2.30	54.81	302.62	60.45	-11.40
2410	42.39	2.12	54.80	301.99	59.94	-11.45
2420	42.40	2.13	54.85	305.69	59.81	-11.49
2430	42.44	2.26	54.94	311.68	60.02	-11.47
2440	42.50	2.25	54.99	315.29	60.34	-11.31
2450	42.49	2.05	54.99	315.19	60.33	-11.26
2460	42.46	2.10	54.96	313.58	59.87	-11.26
2470	42.45	2.24	54.94	311.92	59.22	-11.17
2480	42.44	2.34	54.89	308.01	58.53	-11.15
2490	42.36	2.31	54.81	302.77	58.21	-11.02
2500	42.24	2.30	54.73	297.05	57.98	-10.96

Frequency (MHz)	Gain @ 14dBm Pin, +65°C (dB)	Gain Comp. @ 14dBm Pin, +65°C (dB)	Pout @ 14dBm Pin (dBm)	Pout @ 14dBm Pin, +65°C (W)	Eff. @ 14dBm Pin, +65°C (%)	IRL@ 14dBm Pin, +65°C (dB)
2400	40.61	2.48	54.57	286.71	58.37	-11.07
2410	40.65	2.29	54.55	285.34	57.84	-11.09
2420	40.64	2.31	54.59	287.82	57.69	-11.10
2430	40.67	2.46	54.66	292.40	57.84	-11.10
2440	40.71	2.43	54.70	295.20	58.12	-10.81
2450	40.70	2.28	54.69	294.37	58.10	-10.73
2460	40.65	2.29	54.65	292.07	57.60	-10.71
2470	40.64	2.50	54.63	290.23	57.02	-10.67
2480	40.61	2.66	54.56	285.80	56.44	-10.63
2490	40.54	2.67	54.49	280.89	56.29	-10.56
2500	40.42	2.70	54.41	275.94	56.23	-10.42



P.O. Box 350166, Brooklyn, New York 11235-0003 (718) 934-4500 • Fax (718) 332-4661 For detailed performance specs & shopping online see Mini-Circuits web site



The Design Engineers Search Engine Provides ACTUAL Data Instantly From MINI-CIRCUITS At: www.minicircuits.com

IF/RF MICROWAVE COMPONENTS

Typical Performance Curves

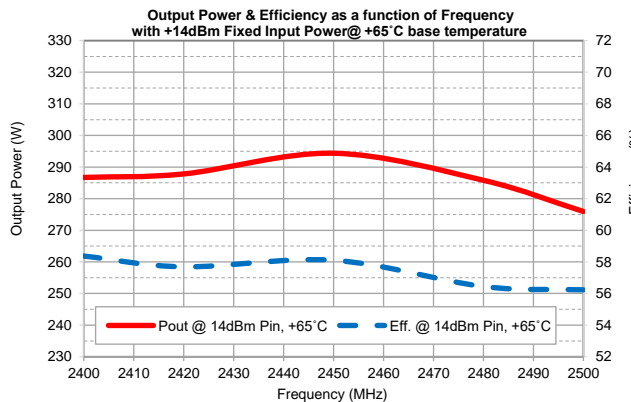
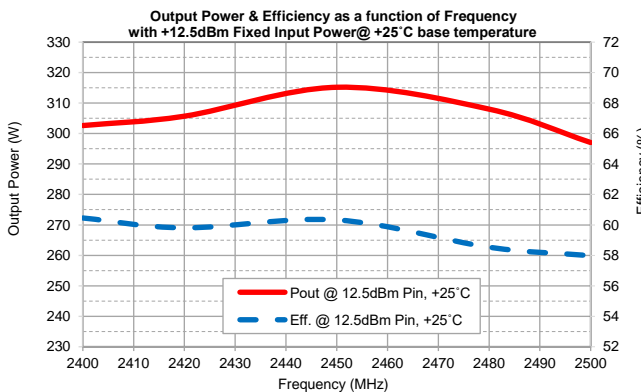
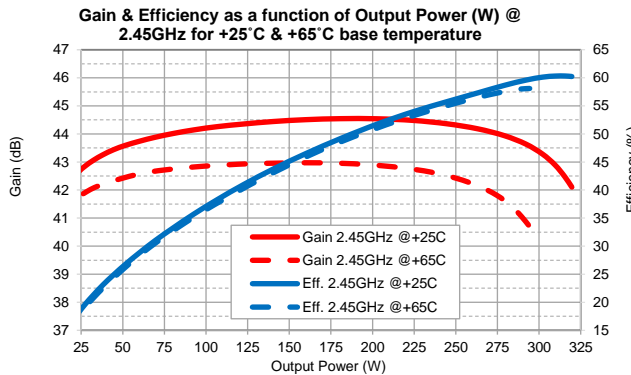
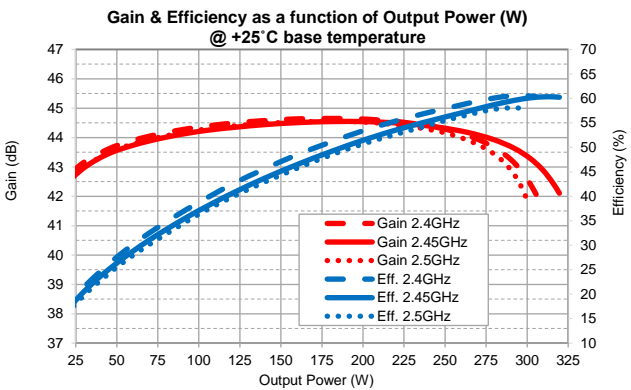
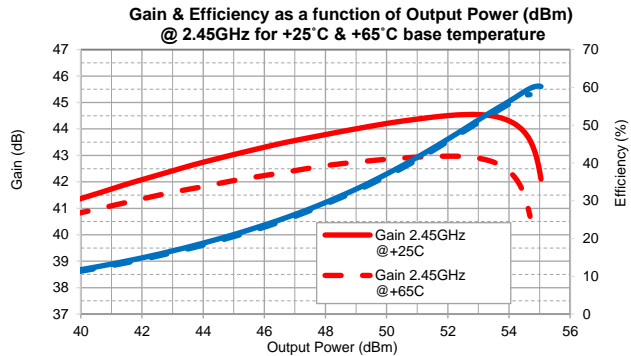
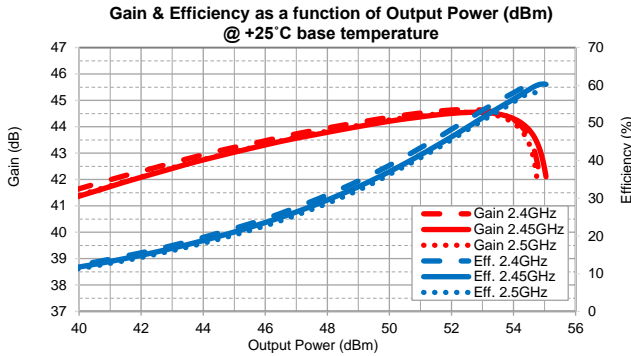

Typical Performance Curves

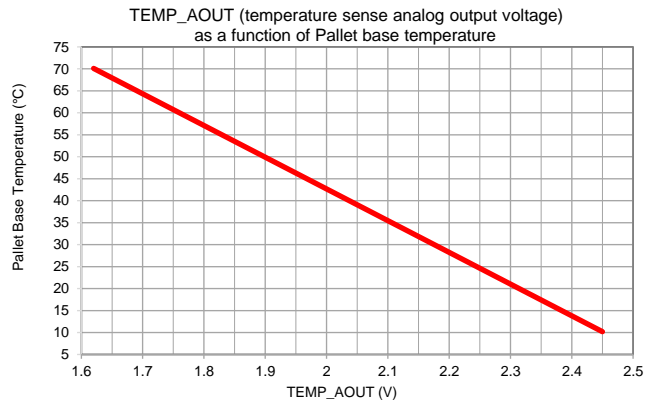
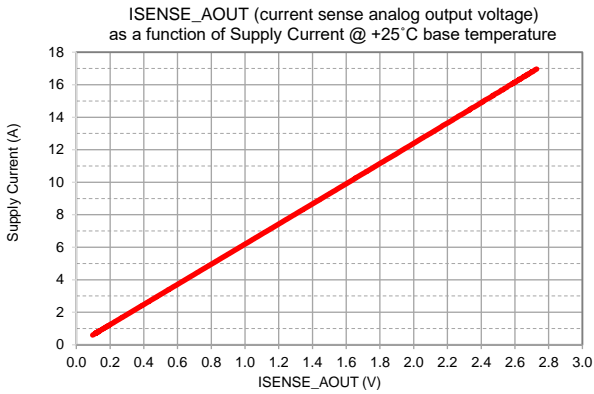
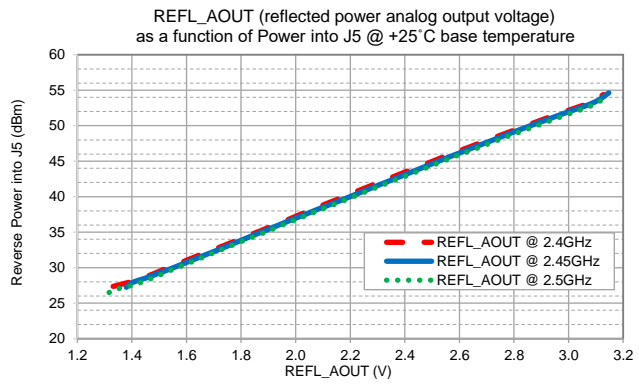
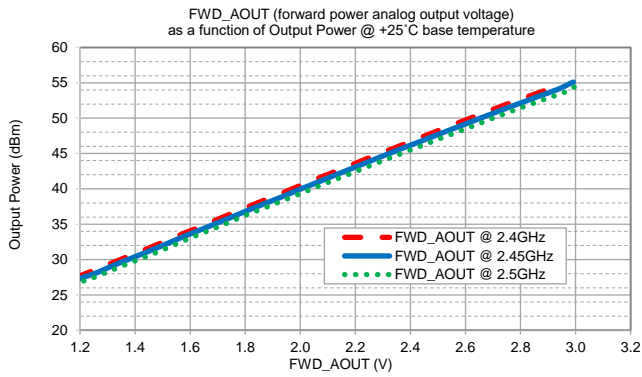
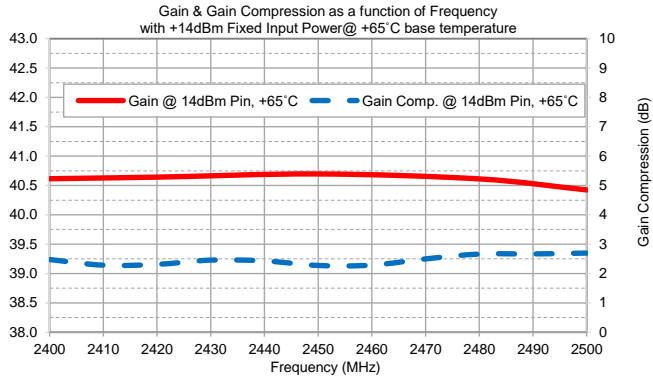
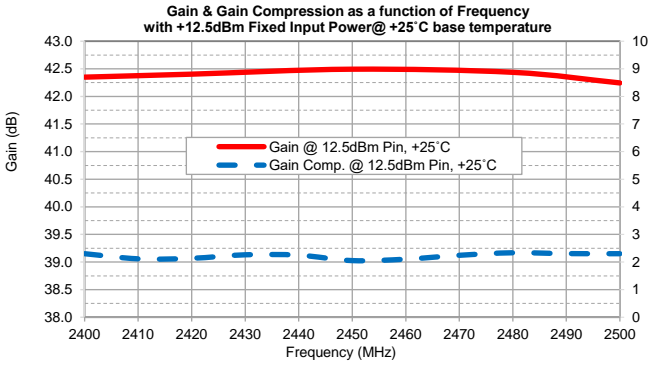

Case Style

Outline Dimensions

VU

VU3193

*M3 SHCS (DIN 912, ISO 21269)
Recommended.
For Mounting, Torque to max.
1.5Nm (13lbf in)

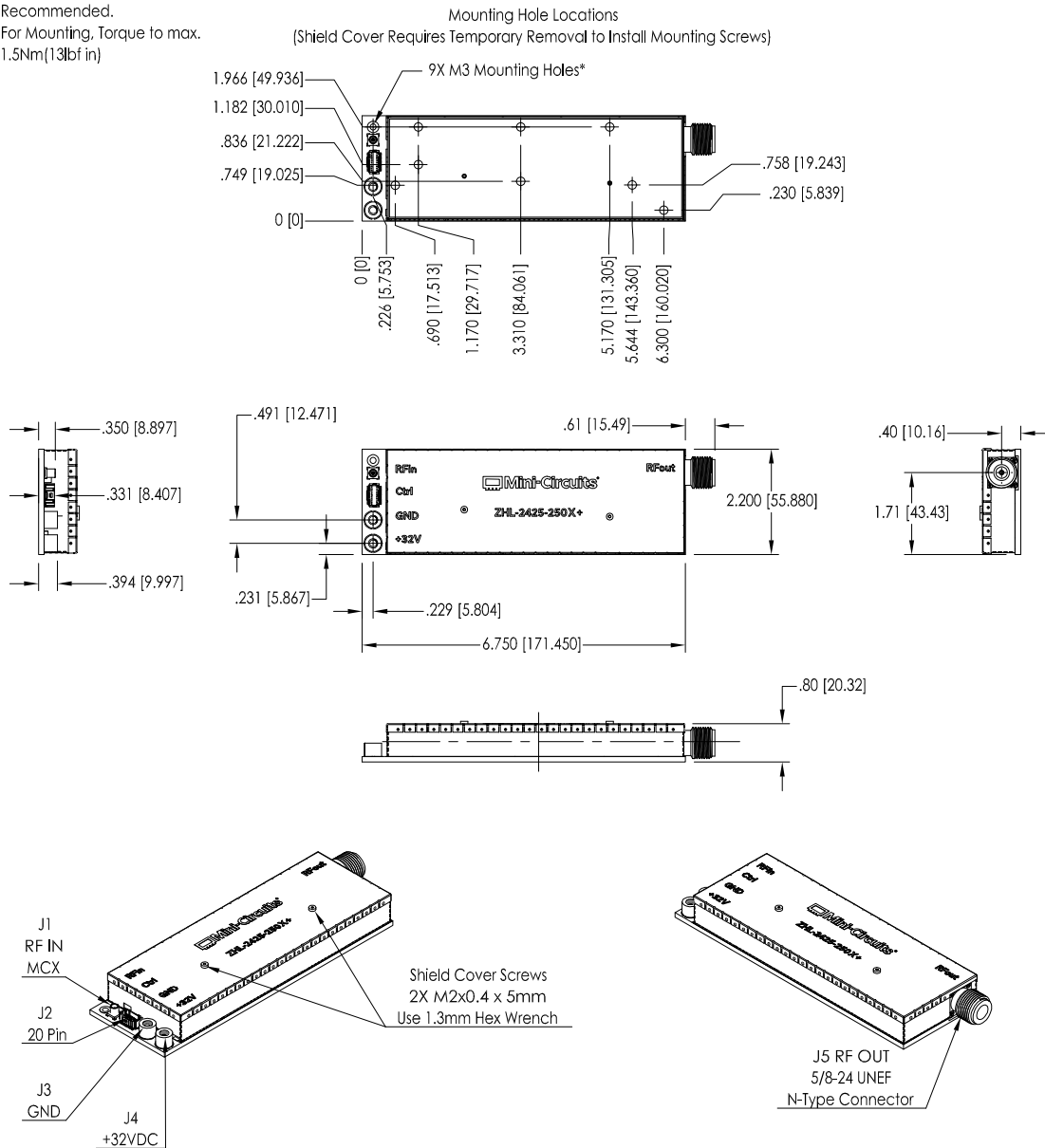

Weight: 290 grams;

Dimensions are in inches (mm). Tolerances: 2 Pl. ± .01 (0.254); 3 Pl. ± .005 (0.127)

Notes:

- Case Material/Finish: Tin Plated steel Shield and Cover. ENIG finish on bottom of PCB.

Mini-Circuits
ISO 9001 ISO 14001 CERTIFIED

ALL NEW
minicircuits.com

P.O. Box 350166, Brooklyn, New York 11235-0003 (718) 934-4500 Fax (718) 332-4661 For detailed performance specs & shopping online see Mini-Circuits web site



The Design Engineers Search Engine Provides ACTUAL Data Instantly From MINI-CIRCUITS At: www.minicircuits.com

RF/IF MICROWAVE COMPONENTS

All Mini-Circuits products are manufactured under exacting quality assurance and control standards, and are capable of meeting published specifications after being subjected to any or all of the following physical and environmental test.

Specification	Test/Inspection Condition	Reference/Spec
Operating Temperature	0°C to +65°C	----
Storage Temperature	-20°C to +85°C	----
Stabilization Bake	125°C, 24 hours (Non-operating)	----
Thermal Imaging	200W REFL, 250W FWD, 25°C Base	----
DC Burn In-Elevated Temperatur	+60°C (Ambient) with Bias. Bias Conditions: +32V ~540mA 500 Hrs. Base plate temperature: 65°C	---
Humidity Storage	Temp: 85°C, Humidity: 85% RH, Non-operating for 1000 Hrs.	----
Thermal Shock	-40°C to +150°C 15 min dwell at extreme temperatures, 1 min transfer 250 cycles	MIL-STD-202, Method 107
ESD Gun Contact	Air Discharge: ±2.0 kV, ±4.0 kV, ±8.0 kV. Contact Discharge: ±2.0 kV, ±4.0 kV, ± 6.0 kV, ±8.0Kv Non-operating Condition. 10 positive & 10 negative charges at each location	IEC 61000-4-2
Drop Test	1.0m drops onto concrete of packed box in 6 orientations	IEC 60068-2-31
Vibration	Sinusoidal vibration, 20 - 2000 Hz, 4 min sweeps, 16 min along each of 3 axes, amplitude limits of 20 G and 0.06 in	MIL-STD-883, Method 2007 Test A