



COAXIAL

# Low Noise Amplifier

## ZHL-1217HLN+ ZHL-1217HLNX+

50Ω 1200 to 1700 MHz

### FEATURES

- Very Low Noise Figure, 1.5 dB max.
- Wideband, 1200 to 1700 MHz
- High Dynamic Range

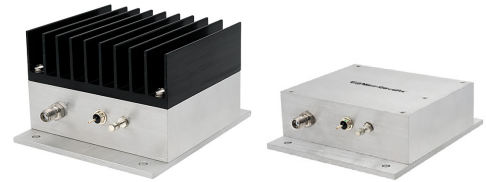

Generic photo used for illustration purposes only

### APPLICATIONS

- GPS
- Mar Sat
- Communication systems

Model No.	ZHL-1217HLN+	ZHL-1217HLNX+ ▲
Case Style	NN92	
Connectors	SMA	

#### +RoHS Compliant

The +Suffix identifies RoHS Compliance.  
See our website for methodologies and qualifications

### ELECTRICAL SPECIFICATIONS AT 25°C

Parameter	Frequency (MHz)	ZHL-1217HLN+			ZHL-1217HLNX+ ▲			Units
		Min.	Typ.	Max.	Min	Typ.	Max.	
Frequency Range		1200		1700	1200		1700	MHz
Noise Figure	1200-1700	—	0.75	1.5	—	0.75	1.5	dB
Gain	1200-1700	36	42	—	36	42	—	dB
Gain Flatness	1200-1700	—	—	±1.0	—	—	±1.0	dB
Output Power at 1dB compression	1200-1700	—	+26	—	—	+26	—	dBm
Output third order intercept point	1200-1700	—	+36	—	—	+36	—	dBm
Input VSWR	1200-1700	—	1.4	—	—	1.4	—	:1
Output VSWR	1200-1700	—	1.3	—	—	1.3	—	:1
DC Supply Voltage		—	15	—	—	15	—	V
Supply Current <sup>1</sup>		—	650	725	—	650	725	mA

Noise Figure specified at room temperature, increases to 2.3 dB max. at +65°C  
Open load is not recommended, potentially can cause damage.  
With no load derate max input power by 20 dB

▲ Heat sink not included. Alternative heat sinking and heat removal must be provided by the user to limit maximum base-plate temperature to 65°C, in order to ensure proper performance. For reference, this requires thermal resistance of user's external heat sink to be 1.8°C/W max.

### ABSOLUTE MAXIMUM RATINGS

Parameter	Ratings
Operating Temperature	-20 °C to +65 °C
Storage Temperature	-55 °C to +100 °C
DC Voltage	+20 V
Input RF Power (no damage)	+10 dBm

Permanent damage may occur if any of these limits are exceeded.

REV. B  
ECO-018348  
ZHL-1217HLN+  
MCL NY  
230626





COAXIAL

# Low Noise Amplifier

## ZHL-1217HLN+ ZHL-1217HLNX+

Mini-Circuits

50Ω 1200 to 1700 MHz

### OUTLINE DRAWING FOR MODELS WITH HEATSINK

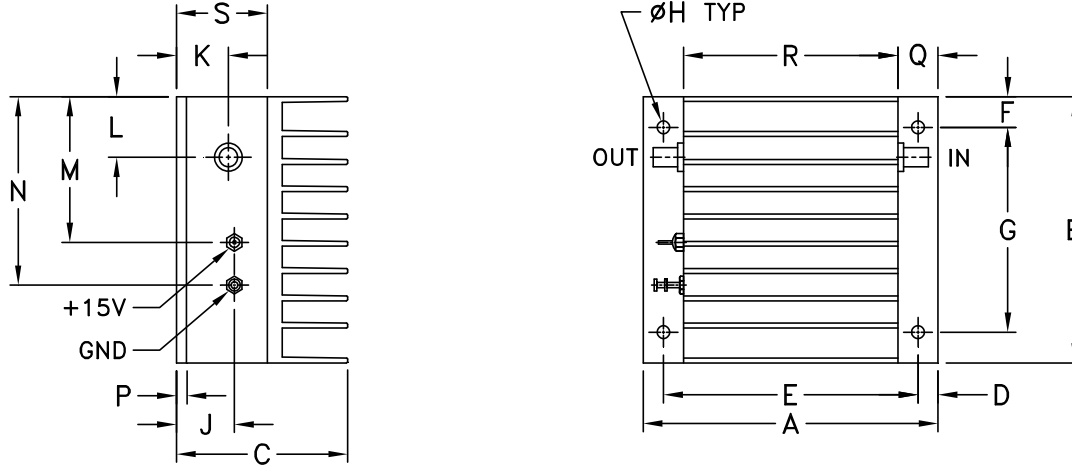

### MOUNTING INFORMATION FOR MODELS WITHOUT HEATSINK

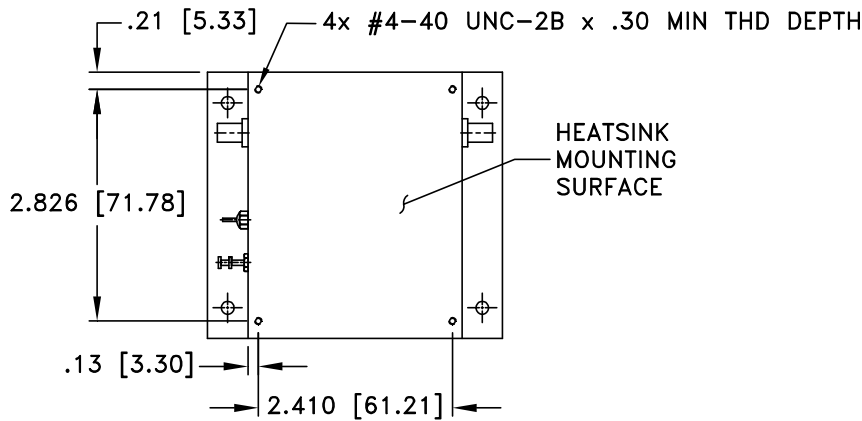

### OUTLINE DIMENSIONS (Inch/mm)

A	B	C	D	E	F	G	H	J	K	L	M	N	P	Q	R	S	wt
3.66	3.25	2.13	.25	3.16	.38	2.50	.156	.72	.64	.74	1.78	2.30	.125	.50	2.66	1.13	grams*
92.96	82.55	54.10	6.35	80.26	9.65	63.50	3.96	18.29	16.26	18.80	45.21	58.42	3.18	12.70	67.56	28.7	500.0

\*362 grams without heatsink





COAXIAL

# Low Noise Amplifier

## ZHL-1217HLN+ ZHL-1217HLNX+

50Ω 1200 to 1700 MHz

### TYPICAL PERFORMANCE DATA AND CHARTS

FREQUENCY (MHz)	GAIN (dB)	DIRECTIVITY (dB)	VSWR (:1)		POUT at 1 dB COMPR. (dBm)	NOISE FIGURE (dB)	IP3 (dBm)
	15V	15V	IN	OUT	15V	15V	15V
1200	41.87	49.61	1.42	1.23	26.54	0.75	37.71
1230	41.92	49.26	1.33	1.23	26.58	0.77	37.73
1260	41.97	47.05	1.27	1.23	26.61	0.73	37.93
1290	42.04	46.11	1.24	1.24	26.66	0.75	38.09
1320	42.11	49.96	1.23	1.26	26.73	0.75	38.33
1350	42.20	43.66	1.24	1.28	26.75	0.75	38.60
1380	42.29	42.83	1.27	1.31	26.82	0.70	39.06
1410	42.37	45.16	1.31	1.33	27.01	0.76	39.38
1440	42.45	44.03	1.35	1.35	27.04	0.74	39.73
1470	42.52	43.46	1.39	1.37	27.12	0.77	39.87
1500	42.55	40.64	1.44	1.38	27.20	0.79	40.32
1550	42.52	39.97	1.50	1.36	27.24	0.78	40.66
1600	42.42	40.39	1.48	1.33	27.38	0.80	41.16
1650	42.29	48.58	1.47	1.27	27.44	0.77	41.51
1700	42.01	43.77	1.44	1.19	27.31	0.73	41.40

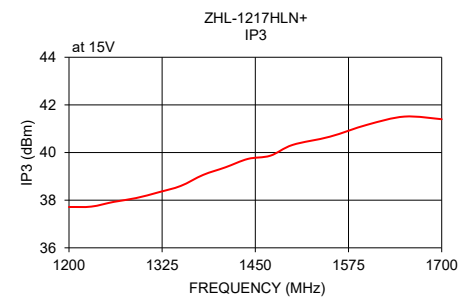
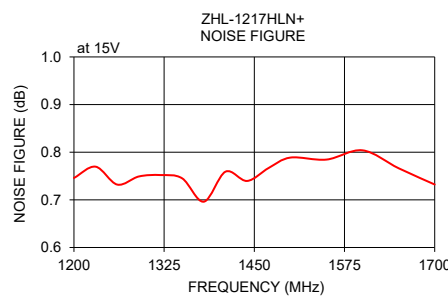
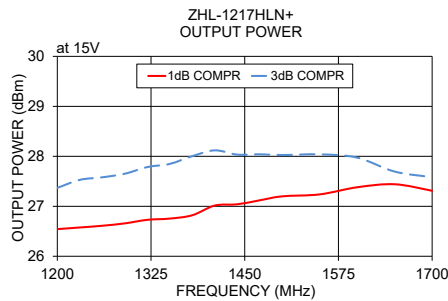
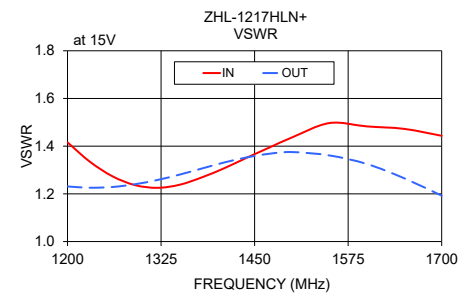
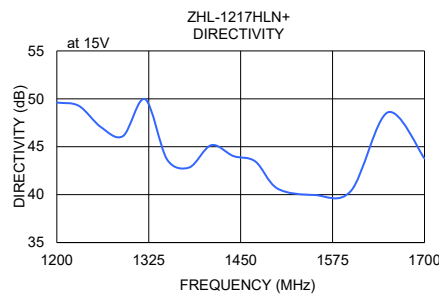
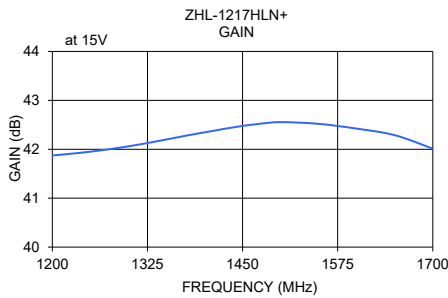

- NOTES**
- A. Performance and quality attributes and conditions not expressly stated in this specification document are intended to be excluded and do not form a part of this specification document.
  - B. Electrical specifications and performance data contained in this specification document are based on Mini-Circuit's applicable established test performance criteria and measurement instructions.
  - C. The parts covered by this specification document are subject to Mini-Circuits standard limited warranty and terms and conditions (collectively, "Standard Terms"); Purchasers of this part are entitled to the rights and benefits contained therein. For a full statement of the standard terms and the exclusive rights and remedies thereunder, please visit Mini-Circuits' website at [www.minicircuits.com/terms/viewterm.html](http://www.minicircuits.com/terms/viewterm.html)



## Typical Performance Data

FREQ. (MHz)	GAIN (dB) 15V	DIRECTIVITY (dB) 15V	VSWR (:1)		NOISE FIGURE (dB) 15V	POUT @ 1 dB COMPRESSION (dBm) 15V	OUTPUT IP3 (dBm) 15V
			IN 15V	OUT 15V			
1200	41.87	49.61	1.42	1.23	0.75	26.54	37.71
1210	41.89	50.10	1.39	1.23	0.80	26.49	37.66
1220	41.90	53.44	1.36	1.23	0.73	26.49	37.73
1230	41.92	49.26	1.33	1.23	0.77	26.58	37.73
1240	41.93	45.29	1.31	1.23	0.76	26.63	37.77
1250	41.95	45.66	1.29	1.23	0.78	26.55	37.85
1260	41.97	47.05	1.27	1.23	0.73	26.61	37.93
1270	41.99	49.33	1.26	1.23	0.70	26.69	37.94
1280	42.01	45.77	1.25	1.24	0.74	26.57	38.03
1290	42.04	46.11	1.24	1.24	0.75	26.66	38.09
1300	42.06	44.87	1.23	1.25	0.72	26.69	38.16
1310	42.09	44.57	1.23	1.25	0.70	26.74	38.22
1320	42.11	49.96	1.23	1.26	0.75	26.73	38.33
1330	42.14	45.05	1.23	1.27	0.79	26.72	38.47
1340	42.17	43.29	1.23	1.27	0.71	26.73	38.45
1350	42.20	43.66	1.24	1.28	0.75	26.75	38.60
1360	42.23	45.26	1.25	1.29	0.75	26.77	38.70
1370	42.26	44.70	1.26	1.30	0.68	26.81	38.86
1380	42.29	42.83	1.27	1.31	0.70	26.82	39.06
1390	42.32	45.55	1.28	1.32	0.77	27.02	39.12
1400	42.35	45.16	1.30	1.32	0.71	26.93	39.22
1410	42.37	45.16	1.31	1.33	0.76	27.01	39.38
1420	42.40	42.22	1.32	1.34	0.73	27.13	39.52
1430	42.43	43.69	1.34	1.35	0.69	27.07	39.66
1440	42.45	44.03	1.35	1.35	0.74	27.04	39.73
1450	42.48	43.50	1.37	1.36	0.83	27.07	39.88
1460	42.50	42.49	1.38	1.36	0.70	27.03	39.90
1470	42.52	43.46	1.39	1.37	0.77	27.12	39.87
1480	42.53	41.95	1.41	1.37	0.69	27.17	39.95
1490	42.54	42.98	1.42	1.37	0.78	27.15	40.20
1500	42.55	40.64	1.44	1.38	0.79	27.20	40.32
1510	42.56	42.45	1.45	1.37	0.75	27.34	40.39
1520	42.56	40.74	1.46	1.37	0.76	27.24	40.41
1530	42.56	44.80	1.48	1.37	0.74	27.25	40.59
1540	42.54	39.84	1.49	1.37	0.81	27.18	40.61
1550	42.52	39.97	1.50	1.36	0.78	27.24	40.66
1560	42.48	41.07	1.50	1.35	0.73	27.35	40.85
1570	42.45	40.80	1.50	1.35	0.69	27.36	40.92
1580	42.43	39.97	1.49	1.34	0.76	27.28	40.94
1590	42.43	45.24	1.49	1.33	0.84	27.25	41.10
1600	42.42	40.39	1.48	1.33	0.80	27.38	41.16
1610	42.41	41.69	1.48	1.32	0.80	27.30	41.30
1620	42.39	43.29	1.48	1.30	0.78	27.34	41.36
1630	42.36	42.98	1.48	1.29	0.76	27.53	41.48
1640	42.33	43.19	1.48	1.28	0.81	27.39	41.45
1650	42.29	48.58	1.47	1.27	0.77	27.44	41.51
1660	42.25	45.44	1.47	1.25	0.83	27.40	41.48
1670	42.20	49.49	1.46	1.24	0.81	27.36	41.52
1680	42.14	43.89	1.46	1.22	0.75	27.44	41.41
1690	42.08	44.07	1.45	1.21	0.83	27.42	41.35
1700	42.01	43.77	1.44	1.19	0.73	27.31	41.40

# Low Noise Amplifier

# ZHL-1217HLN+

## Typical Performance Curves

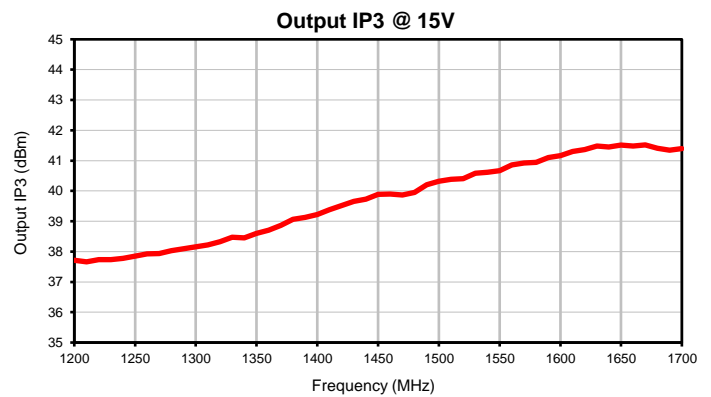
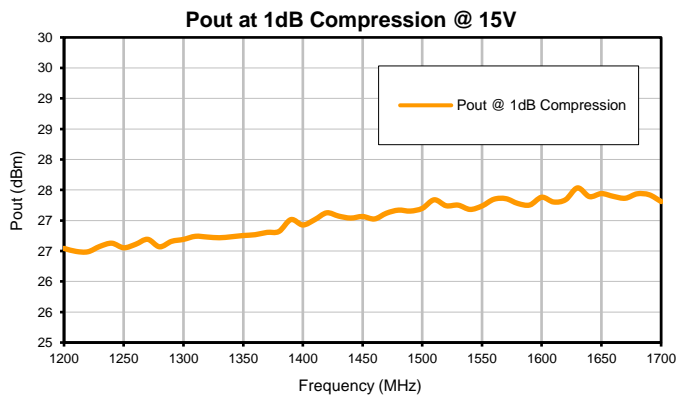
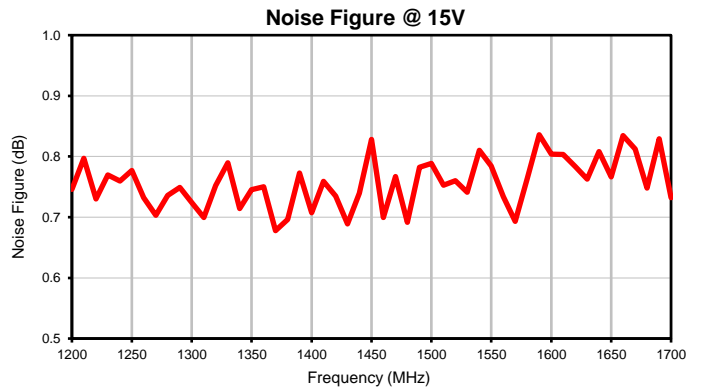
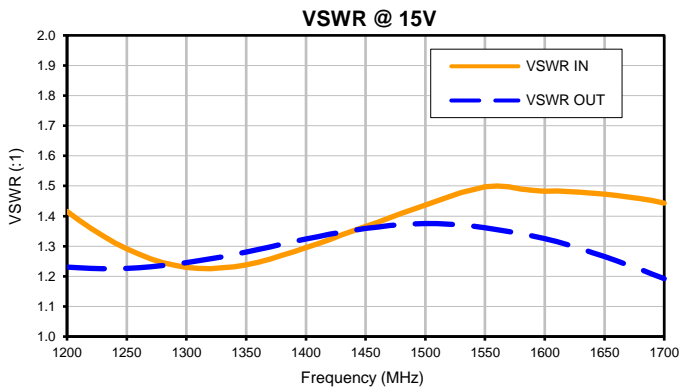
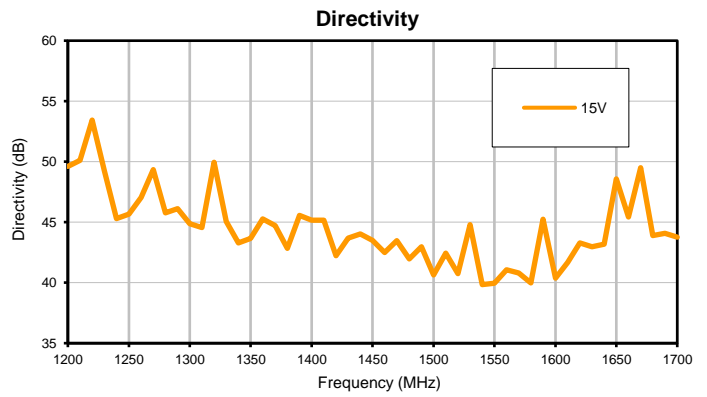
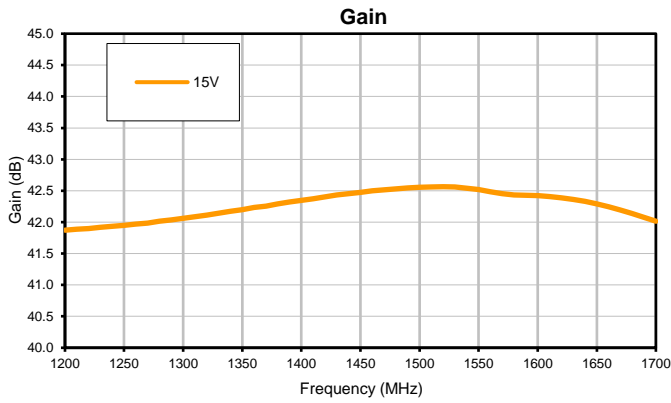

### Outline Dimensions

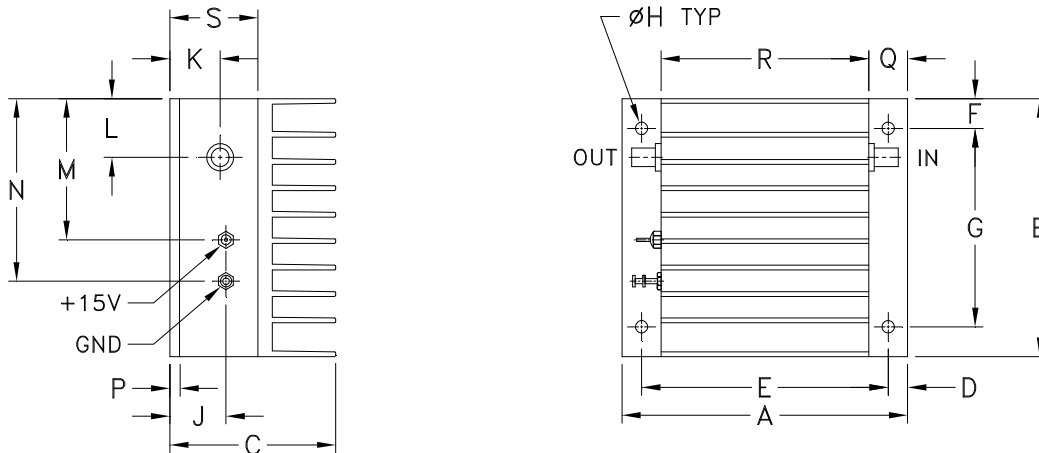

#### MOUNTING INFORMATION FOR MODELS WITHOUT HEATSINK

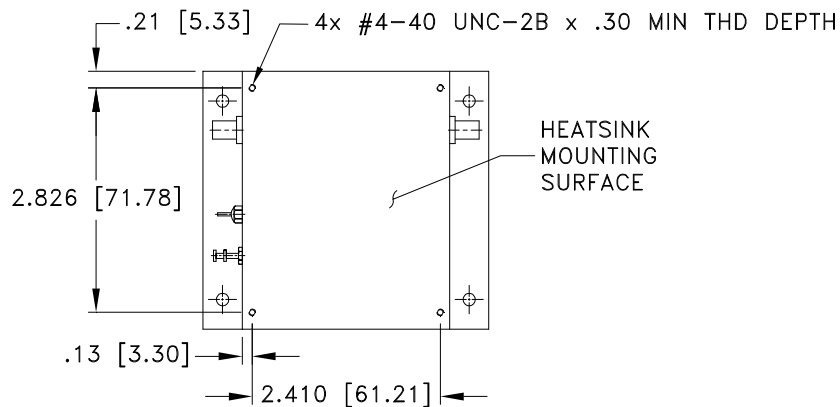

CASE#	A	B	C	D	E	F	G	H	J	K	L	M	N
NN92	3.66 (92.96)	3.25 (82.55)	2.13 (54.10)	.25 (6.35)	3.16 (80.26)	.38 (9.65)	2.50 (63.50)	.156 (3.96)	.72 (18.29)	.64 (16.26)	.74 (18.80)	1.78 (45.21)	2.30 (58.42)

CASE#	P	Q	R	S	WT. GRAMS	WT. WITHOUT HEATSINK GRAMS
NN92	.125 (3.18)	.50 (12.70)	2.66 (67.56)	1.13 (28.58)	500.0	362.0

Dimensions are in inches (mm). Tolerances: 2 Pl. + .03; 3 Pl. + .015

#### Notes:

- Case material: Aluminum alloy.
- Case and mounting bracket finish:  
For RoHS Case Styles: Clear chemical conversion coating, non-chrome or trivalent chrome based.
- Heat sink finish: Black anodize.

All Mini-Circuits products are manufactured under exacting quality assurance and control standards, and are capable of meeting published specifications after being subjected to any or all of the following physical and environmental test.

Specification	Test/Inspection Condition	Reference/Spec
Operating Temperature	-54° to 65°C Ambient Environment	Individual Model Data Sheet
Storage Temperature	-55° to 100° C Ambient Environment	Individual Model Data Sheet
Stabilization Bake	(non-operating) 125°C, 24 hours	- - -
Burn-in at Elevated Temp.	(DC on) 160 hours at 85° C	MIL-STD-202, Method 108
Thermal Shock	-55° to 100°C, 5 cycles	MIL-STD-202, Method 107, Condition A, except 100°C