



COAXIAL High Power Amplifier

ZHL-10W-2G+ ZHL-10W-2GX+

50Ω 10W 800 to 2000 MHz

FEATURES

- High power, 10 Watt
- Low Current consumption, 4A typ.
- High IP3, +50 dBm typ.
- Usable over 700 to 2200 MHz
- No damage with an open or short output load under full CW output power

APPLICATIONS

- Cellular
- PCN
- GSM
- ISM
- Lab Test

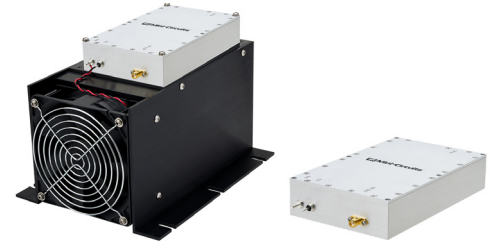

Generic photo used for illustration purposes only

Model No.	ZHL-10W-2G+	ZHL-10W-2GX+ [▲]
Case Style	BT1204	
Connectors	SMA	

+RoHS Compliant
The +Suffix identifies RoHS Compliance.
See our website for methodologies and qualifications

ELECTRICAL SPECIFICATIONS

Parameter	ZHL-10W-2G+ ZHL-10W-2GX+ [▲]			Units
	Min.	Typ.	Max.	
Frequency Range	800		2000	MHz
Gain	40	43	49	dB
Gain Flatness			±2.0	dB
Output Power at 1dB compression	+39	+40		dBm
Saturated Output Power at 3dB compression	+40	+41		dBm
Noise Figure		7.0		dB
Output third order intercept point		+50		dBm
Input VSWR		1.3		:1
Output VSWR		1.3		:1
DC Supply Voltage		24	28	V
Supply Current ¹			5.0	A

1. Power Supply should be capable of delivering 6A at start up.

[▲] Heat sink and fan not included. Alternative heat sinking and heat removal must be provided by the user to limit maximum base-plate temperature to 75°C, in order to ensure proper performance. For reference, this requires thermal resistance of user's external heat sink to be 0.08°C/W max.

ABSOLUTE MAXIMUM RATINGS

Parameter	Ratings
Operating Temperature	-20 °C to +65 °C
Storage Temperature	-55 °C to +100 °C
Base Plate Temperature	75 °C
Input RF Power (no damage)	+1 dBm

Permanent damage may occur if any of these limits are exceeded.





COAXIAL

High Power Amplifier

ZHL-10W-2G+ ZHL-10W-2GX+

Mini-Circuits

50Ω 10W 800 to 2000 MHz

OUTLINE DRAWING

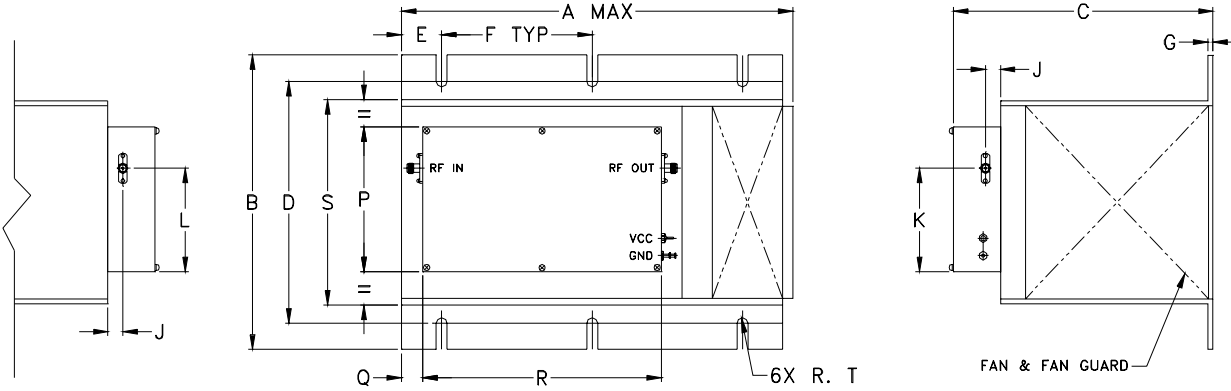

MOUNTING INFORMATION FOR MODELS WITHOUT HEATSINK.

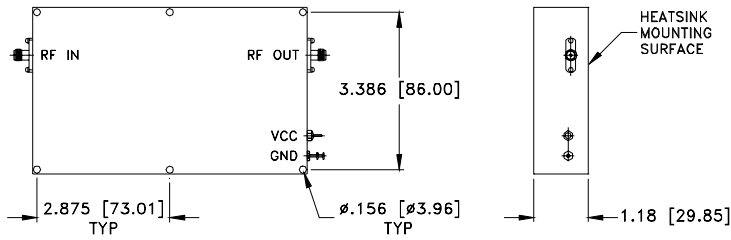

OUTLINE DIMENSIONS (Inch mm)

A	B	C	D	E	F	G	H	J	K	L	M	N	P	Q	R	S	T	wt
9.85	7.3	6.5	6.00	1.00	3.75	.13	—	.37	2.56	2.56	—	—	3.58	.5	5.95	5.1	.135	grams
250.19	185.42	165.10	152.40	25.40	95.25	3.30	—	9.40	65.02	65.02	—	—	90.93	12.70	151.13	129.54	3.43	4265
																		*580 grams without heatsink



COAXIAL

High Power Amplifier

ZHL-10W-2G+ ZHL-10W-2GX+

50Ω 10W 800 to 2000 MHz

TYPICAL PERFORMANCE DATA AND CHARTS

Frequency (MHz)	Gain (dB)			VSWR (:1)		Noise Figure (dB)	Pout at 1dB Compr. (dBm)	IP3 (dBm)
	21V	24V	27V	IN	OUT			
800.00	43.87	43.85	43.83	1.33	1.05	5.15	40.81	52.13
900.00	43.69	43.66	43.64	1.25	1.13	5.07	41.27	52.62
1000.00	43.45	43.42	43.40	1.30	1.14	5.05	41.72	53.42
1100.00	43.20	43.17	43.15	1.38	1.09	5.09	41.89	53.54
1200.00	43.05	43.03	43.01	1.43	1.07	5.09	41.91	53.78
1300.00	43.21	43.19	43.17	1.42	1.17	5.08	41.56	54.28
1400.00	43.41	43.40	43.39	1.37	1.20	5.11	40.89	52.92
1500.00	43.47	43.44	43.43	1.32	1.12	5.11	40.66	52.84
1600.00	43.44	43.40	43.37	1.26	1.09	5.13	40.27	51.87
1700.00	43.51	43.45	43.41	1.22	1.18	5.15	39.69	51.58
1800.00	43.81	43.72	43.67	1.17	1.27	5.23	40.05	51.60
1900.00	44.56	44.43	44.37	1.11	1.29	5.24	40.58	52.24
2000.00	44.57	44.45	44.38	1.12	1.34	5.30	40.29	50.67

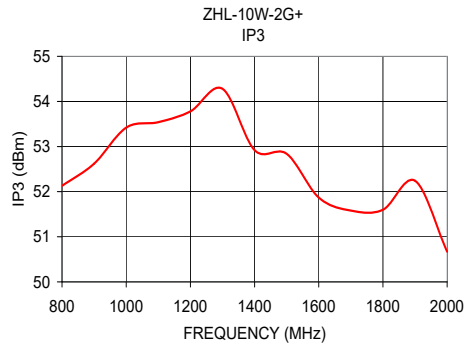
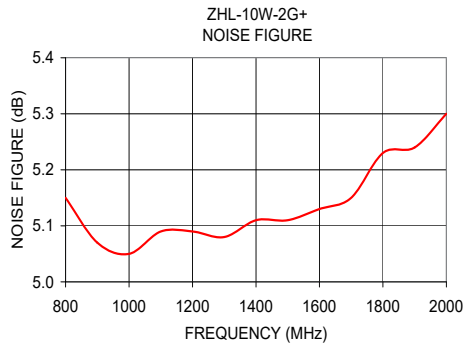
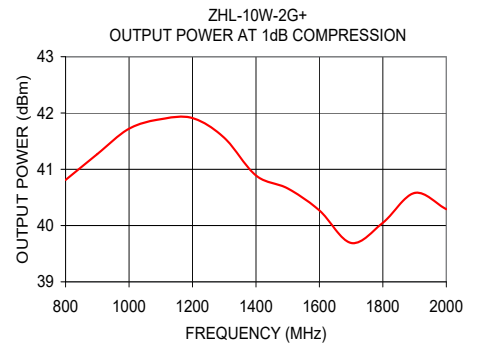
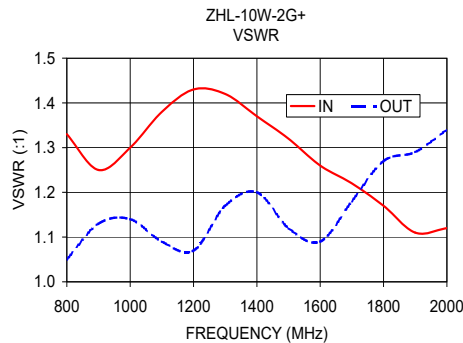
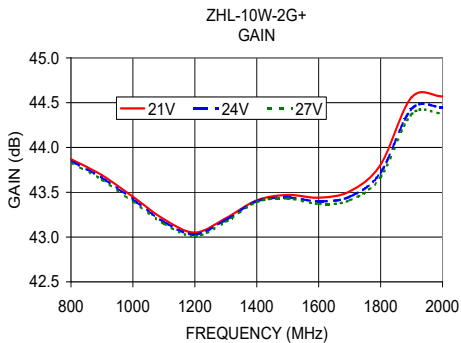

NOTES

- A. Performance and quality attributes and conditions not expressly stated in this specification document are intended to be excluded and do not form a part of this specification document.
- B. Electrical specifications and performance data contained in this specification document are based on Mini-Circuit's applicable established test performance criteria and measurement instructions.
- C. The parts covered by this specification document are subject to Mini-Circuits standard limited warranty and terms and conditions (collectively, "Standard Terms"); Purchasers of this part are entitled to the rights and benefits contained therein. For a full statement of the standard terms and the exclusive rights and remedies thereunder, please visit Mini-Circuits' website at www.minicircuits.com/terms/viewterm.html



Amplifier

ZHL-10W-2G+

Typical Performance Data

FREQUENCY (MHz)	GAIN (dB) 24V	DIRECTIVITY (dB) 24V	VSWR IN (:1) 24V	VSWR OUT (:1) 24V	NOISE FIGURE (dB) 24V	Pout at 1dB Comp. (dBm) 24V	Output IP3 (dBm) 24V
800.0	43.85	44.70	1.33	1.05	5.15	40.81	52.13
900.0	43.66	47.50	1.25	1.13	5.07	41.27	52.62
1000.0	43.42	47.10	1.30	1.14	5.05	41.72	53.42
1100.0	43.17	53.40	1.38	1.09	5.09	41.89	53.54
1200.0	43.03	47.00	1.43	1.07	5.09	41.91	53.78
1300.0	43.19	46.10	1.42	1.17	5.08	41.56	54.28
1400.0	43.40	52.70	1.37	1.20	5.11	40.89	52.92
1500.0	43.44	49.40	1.32	1.12	5.11	40.66	52.84
1600.0	43.40	43.90	1.26	1.09	5.13	40.27	51.87
1700.0	43.45	50.50	1.22	1.18	5.15	39.69	51.58
1800.0	43.72	44.80	1.17	1.27	5.23	40.05	51.60
1900.0	44.43	39.40	1.11	1.29	5.24	40.58	52.24
2000.0	44.45	46.10	1.12	1.34	5.30	40.29	50.67

REV. X1
ZHL-10W-2G+
070515
Page 1 of 1



IF/RF MICROWAVE COMPONENTS • ISO 9001 ISO 14001 AS 9100 CERTIFIED RoHS compliant
P.O. Box 350166, Brooklyn, New York 11235-0003 (718) 934-4500 Fax (718) 332-4661



The Design Engineers Search Engine finds the model you need, Instantly • For detailed performance specs & shopping online see



Typical Performance Curves

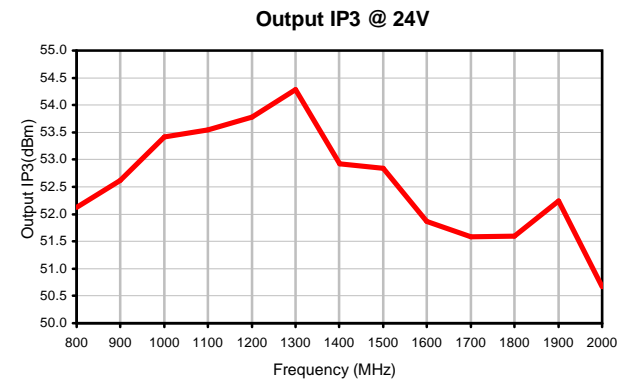
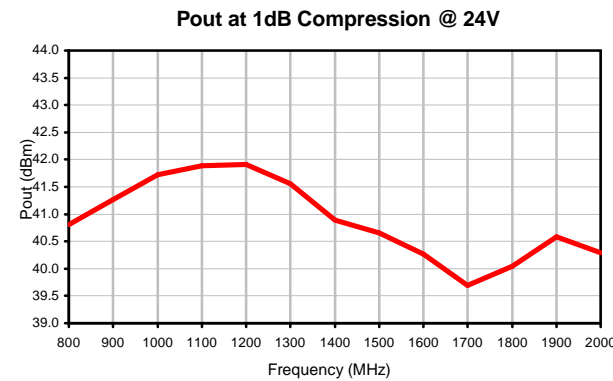
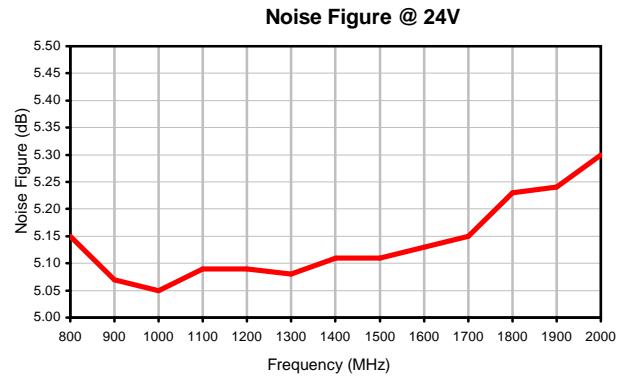
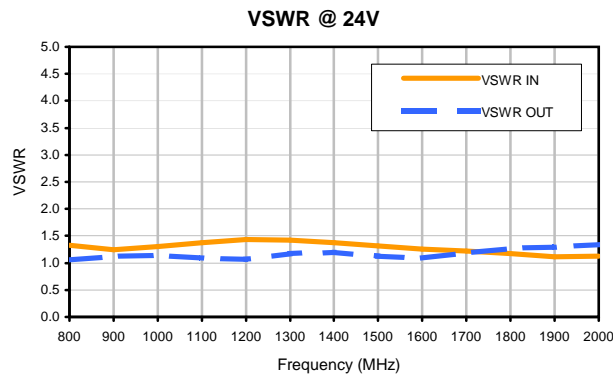
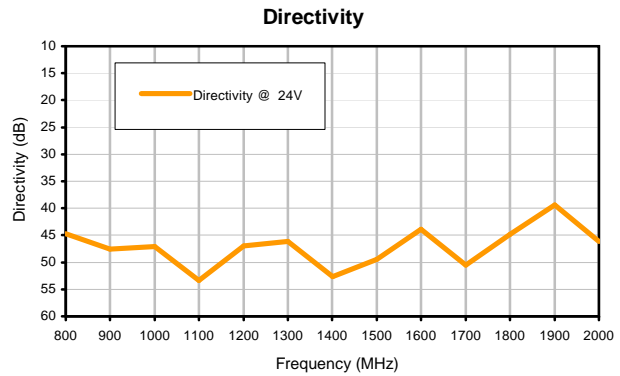
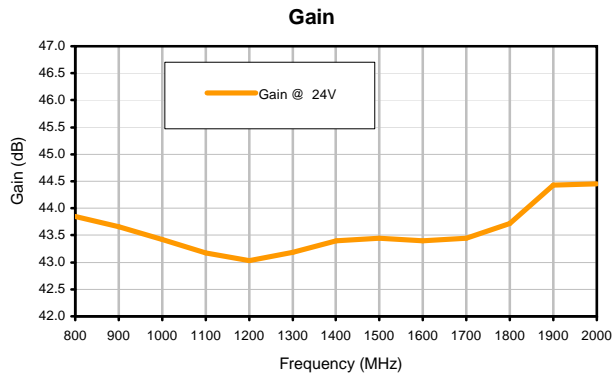

Outline Dimensions

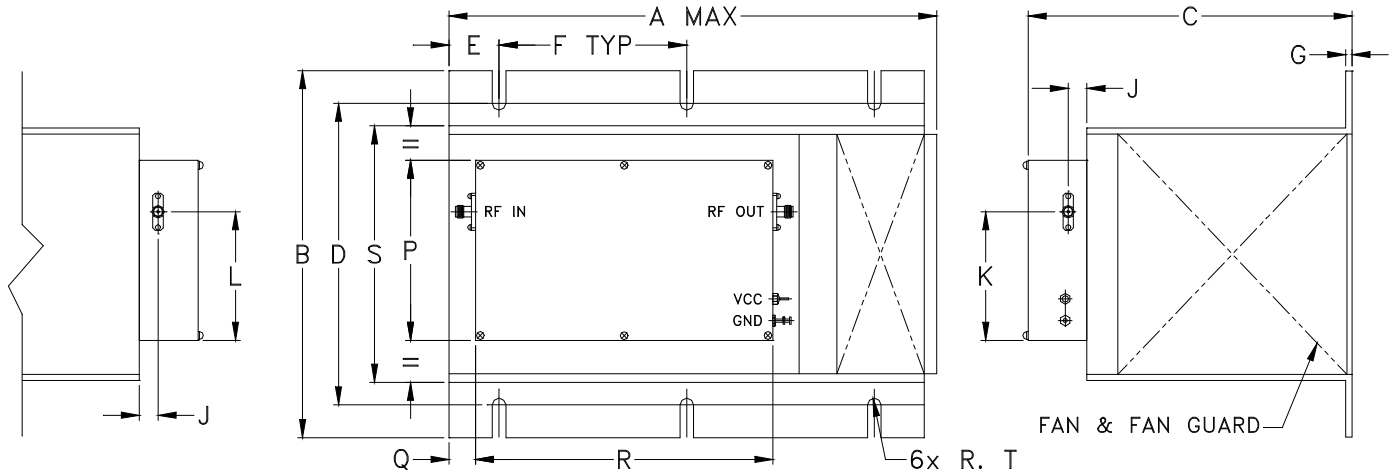

MOUNTING INFORMATION FOR MODELS WITHOUT HEATSINK.

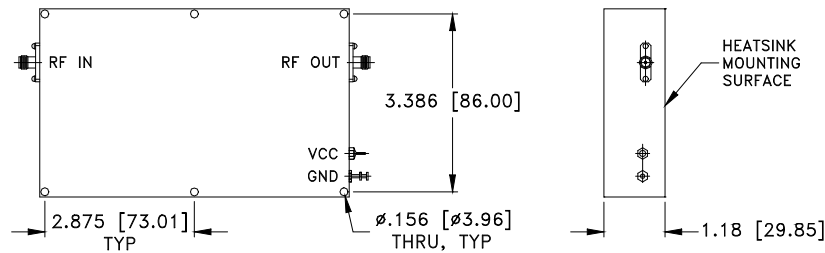

CASE#	A	B	C	D	E	F	G	H	J	K	L	M	N
BT1204	9.85 (250.19)	7.3 (185.42)	6.5 (165.10)	6.00 (152.40)	1.00 (25.40)	3.75 (95.25)	.13 (3.30)	- -	.37 (9.40)	2.56 (65.02)	2.56 (65.02)	- -	- -

CASE#	P	Q	R	S	T	WT, GRAM	WT WITHOUT HEATSINK, GRAM
BT1204	3.58 (90.93)	.5 (12.70)	5.95 (151.13)	5.1 (129.54)	.135 (3.43)	4265	580

Dimensions are in inches (mm). Tolerances: 1 Pl. $\pm .1$; 2 Pl. $\pm .03$; 3 Pl. $\pm .015$

Notes:

- Case material: Aluminum alloy.
- Finish:
For RoHS Case Styles: Clear Chemical conversion coating, non-chrome or trivalent chrome based.
- Heatsink finish: Black anodize.
- Refer to the individual model data sheet for the type of connectors available.
- Recommended screws for mounting model without heat sink on 3/32" thick sheet: #6-32, 1.50" Length.



P.O. Box 350166, Brooklyn, New York 11235-0003 (718) 934-4500 Fax (718) 332-4661 For detailed performance specs & shopping online see Mini-Circuits web site



The Design Engineers Search Engine Provides ACTUAL Data Instantly From MINI-CIRCUITS At: www.minicircuits.com

RF/IF MICROWAVE COMPONENTS

All Mini-Circuits products are manufactured under exacting quality assurance and control standards, and are capable of meeting published specifications after being subjected to any or all of the following physical and environmental test.

Specification	Test/Inspection Condition	Reference/Spec
Operating Temperature	-20° to 65° C Ambient Environment	Individual Model Data Sheet
Storage Temperature	-55° to 100° C Ambient Environment	Individual Model Data Sheet
Stabilization Bake	(non-operating) 125°C, 24 hours	- - -
Burn-in at Elevated Temp.	(DC on) 160 hours at 85° C	MIL-STD-202, Method 108
Thermal Shock	-55° to 100°C, 5 cycles	MIL-STD-202, Method 107, Condition A, except 100°C