



COAXIAL

# RF Instrument Amplifier ZHL-10M4G21W2+

50Ω 10 to 4200 MHz Broadband 2W N-Type

## THE BIG DEAL

- Broadband, 10 to 4200MHz
- High Gain, 44dB typ.
- High P1dB, +33dBm, typ.
- High OIP3, +46dBm typ.
- Built-in 110/220V AC power supply



Generic photo used for illustration purposes only

## APPLICATIONS

- Communication Systems
- R&D, Production, and OTA Test Systems
- Test & Measurement Equipment
- General Laboratory Applications

## PRODUCT OVERVIEW

Mini-Circuits' ZHL-10M4G21W2+ is an instrument amplifier providing more than 1W of output power with a typical small signal gain of 44dB over the 10 to 4200 MHz frequency band. The amplifier uses state-of-the-art semiconductor technology and can be used in a wide range of applications. This model features a built-in digital step attenuator on the input providing gain control from 0 to 15 dB in 1 dB steps with push-button attenuation control on the front panel. The amplifier runs on a built-in 110/220V power supply, making it easy to use in most lab environments. It features thermal self-protection, preventing damage to the amplifier and providing added reliability. It comes housed in a light-weight aluminum alloy case (15.35 x 8.27 x 3.25") with N-type connectors, ideal for bench-top use. 2 N-male to SMA-female adapters come included for the user's convenience.

## FUNCTIONAL DIAGRAM

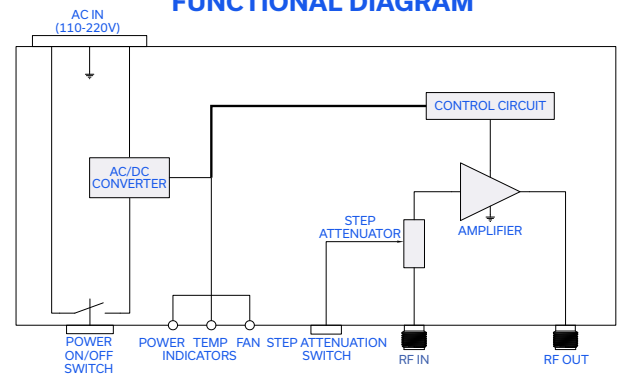

## KEY FEATURES

Feature	Advantages
Extremely Broadband, 10 to 4200 MHz and High Power, 1.9W	One single amplifier that covers the entire frequency band delivering rated power.
High Gain, 44 dB Typ.	High gain allows low drive levels to achieve rated output power which can be obtained from many standard lab generators.
Built-in digital step attenuator, 0 - 15 dB, 1 dB step	Allows up to 15 dB variable gain control via push-button control on the front panel.
High OIP3, +46 dBm Typ.	High OIP3 makes the amplifier suitable for applications requiring high linearity such as digitally modulated signals.
Built-in 110V/220V power supply	Operating from a standard AC line power supply, the ZHL-10M4G21W2X+ can be powered from 110 to 220V, making the amplifier versatile for use in most lab environments.
Thermally-self-protected	A built-in sensing feature signals the unit to power off when the amplifier reaches its maximum rated operating temperature, preventing damage to the equipment and providing added reliability.





COAXIAL

# RF Instrument Amplifier **ZHL-10M4G21W2+**

50Ω 10 to 4200 MHz Broadband 2W N-Type

## ELECTRICAL SPECIFICATIONS AT $T_{AMBIENT} = +25^{\circ}C$

Parameter	Symbol	Condition	Min.	Typ.	Max.	Units
Frequency Range	f		10		4200	MHz
Small Signal Gain	$G_{SS}$		38	44		dB
Small Signal Gain Flatness	$G_{SS-FLAT}$			$\pm 1.3$	$\pm 2.1$	dB
Output Power at 1 dB compression	$P_{1dB}$	10 - 3600 MHz	+29	+33		dBm
		3600 - 4200 MHz	+27	+31		
Noise Figure	NF			5.6		dB
Output Third Order Intercept Point	OIP3	$P_{OUT} = +20dBm/ tone$		+46		dBm
Input VSWR	I-VSWR			1.3	3.0	:1
Output VSWR	O-VSWR			1.5	3.0	:1
DC Supply Voltage	$V_{AC}$		85	110/220	264	V



COAXIAL

# RF Instrument Amplifier **ZHL-10M4G21W2+**

Mini-Circuits

50Ω 10 to 4200 MHz Broadband 2W N-Type

TYPICAL PERFORMANCE DATA AT  $T_{AMBIENT} = 25^{\circ}\text{C}$ , 50 OHM

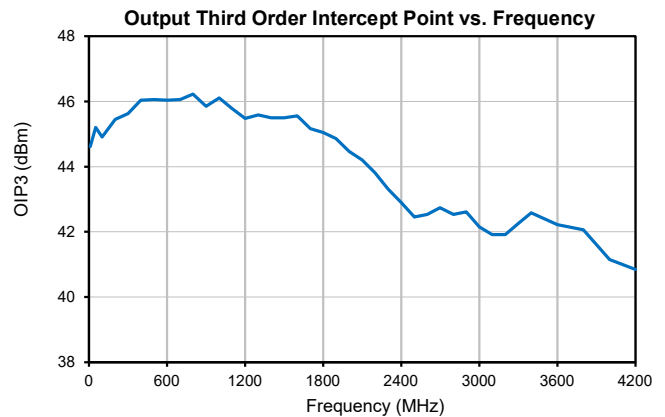
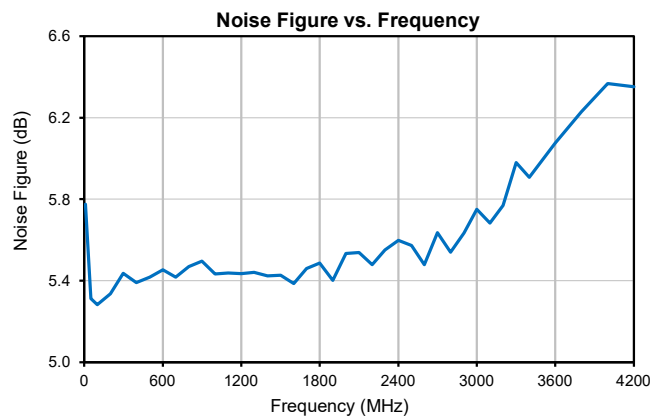
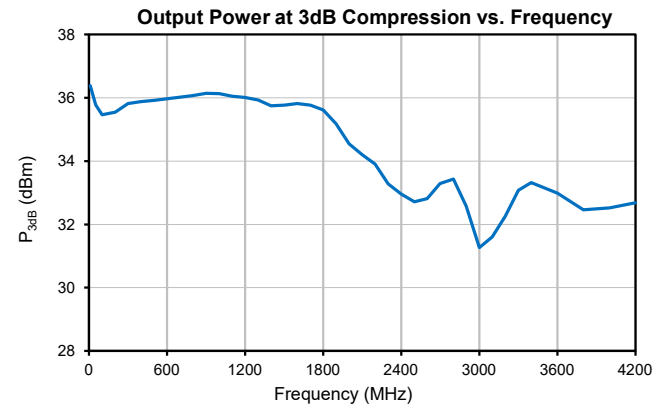
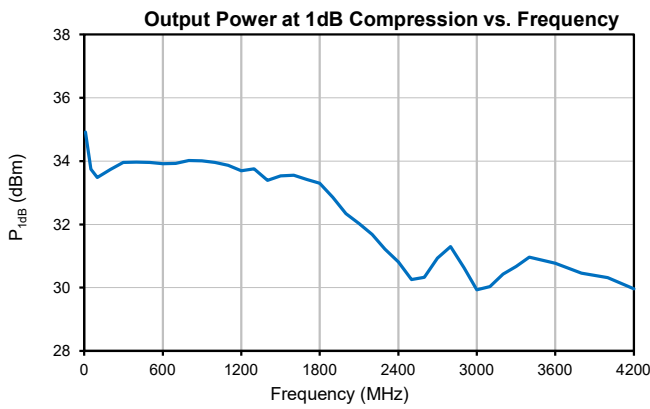
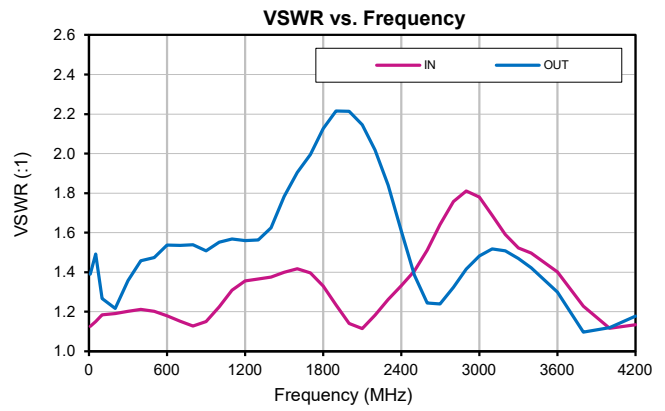
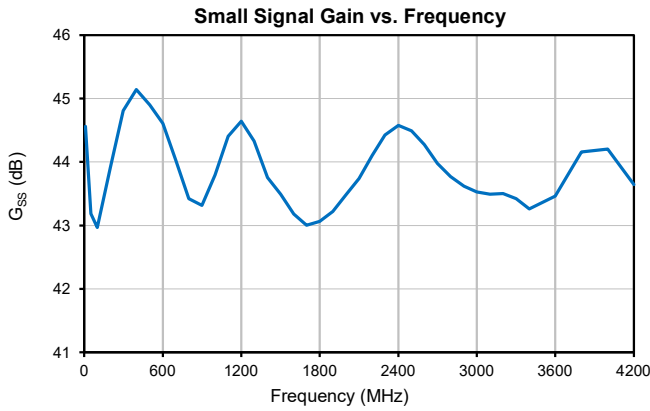



# COAXIAL

# RF Instrument Amplifier **ZHL-10M4G21W2+**

Mini-Circuits

50Ω 10 to 4200 MHz Broadband 2W N-Type

## ABSOLUTE MAXIMUM RATINGS

Parameter	Ratings	
Operating Temperature	ZHL-10M4G21W2+	T <sub>AMBIENT</sub> : 0 °C to +55 °C
Storage Temperature	-40 °C to +70 °C	
No damage with an open or short at P <sub>OUT</sub> = +30 dBm CW for 2 minutes max		
RF Input Power (no damage)	0 dBm	

Permanent damage may occur if any of these limits are exceeded.

## COAXIAL CONNECTIONS

IN (RF IN)	N-Female
OUT (RF OUT)	N-Female

## CASE STYLE DRAWING

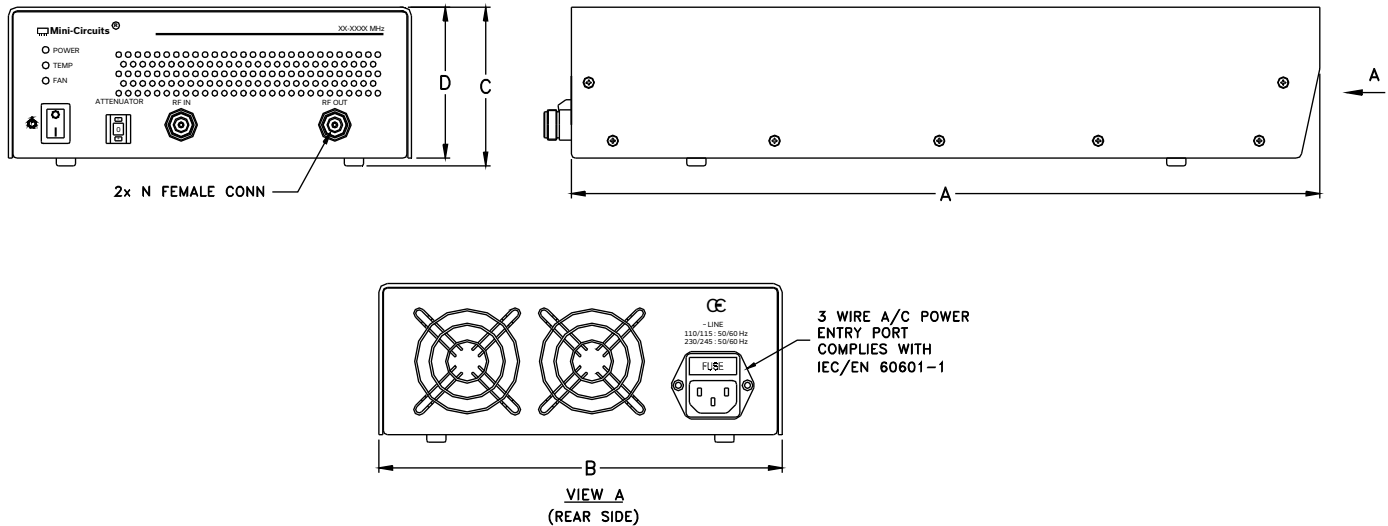

## OUTLINE DIMENSIONS (Inch/mm)

A	B	C	D	WT.
15.35	8.27	3.25	3.09	GRAM
389.89	210.06	82.55	78.49	3550





COAXIAL

# RF Instrument Amplifier **ZHL-10M4G21W2+**

50Ω 10 to 4200 MHz Broadband 2W N-Type

### ADDITIONAL INFORMATION IS AVAILABLE ON OUR DASHBOARD.

Performance Data	Table
	Graphs
	S-Parameter (S2P Files) Data Set (.zip file)
RoHS Status	Compliant
Environmental Ratings	ENV35

### ORDERING INFORMATION

Model No. Links	<a href="#">ZHL-10M4G21W2+</a>
Case Style	PJ2059-1
Connector	IN (N-Female) / OUT (N-Female)

#### NOTES

- A. Performance and quality attributes and conditions not expressly stated in this specification document are intended to be excluded and do not form a part of this specification document.
- B. Electrical specifications and performance data contained in this specification document are based on Mini-Circuit's applicable established test performance criteria and measurement instructions.
- C. The parts covered by this specification document are subject to Mini-Circuits standard limited warranty and terms and conditions (collectively, "Standard Terms"); Purchasers of this part are entitled to the rights and benefits contained therein. For a full statement of the standard terms and the exclusive rights and remedies thereunder, please visit Mini-Circuits' website at [www.minicircuits.com/terms/viewterm.html](http://www.minicircuits.com/terms/viewterm.html)



# Coaxial Amplifier

# ZHL-10M4G21W2+

## Typical Performance Data

Frequency (MHz)	Small Signal Gain (dB)	Isolation (dB)	VSWR (:1)		P <sub>OUT</sub> @ 1 dB Compression (dBm)	P <sub>OUT</sub> @ 3 dB Compression (dBm)	OIP3 (dBm)	Noise Figure (dB)
			In	Out				
10	44.56	82.66	1.13	1.39	34.92	36.39	44.61	5.77
50	43.18	94.14	1.15	1.49	33.74	35.78	45.20	5.31
100	42.97	100.28	1.18	1.27	33.48	35.46	44.91	5.28
200	43.92	105.30	1.19	1.22	33.74	35.54	45.45	5.34
300	44.81	98.25	1.20	1.36	33.96	35.81	45.62	5.44
400	45.14	96.68	1.21	1.46	33.97	35.88	46.04	5.39
500	44.90	94.89	1.20	1.47	33.96	35.92	46.05	5.42
600	44.61	92.80	1.18	1.54	33.92	35.97	46.04	5.45
700	44.03	97.43	1.15	1.54	33.93	36.02	46.06	5.42
800	43.42	92.56	1.13	1.54	34.02	36.07	46.22	5.47
900	43.31	94.44	1.15	1.51	34.01	36.14	45.85	5.50
1000	43.79	90.31	1.22	1.55	33.95	36.13	46.10	5.43
1100	44.41	90.57	1.31	1.57	33.87	36.05	45.78	5.44
1200	44.64	89.82	1.36	1.56	33.69	36.01	45.48	5.43
1300	44.33	89.79	1.37	1.56	33.76	35.93	45.59	5.44
1400	43.75	89.54	1.38	1.62	33.39	35.75	45.50	5.42
1500	43.49	89.59	1.40	1.78	33.53	35.77	45.50	5.43
1600	43.18	90.56	1.42	1.90	33.55	35.81	45.55	5.39
1700	43.00	91.94	1.40	2.00	33.42	35.76	45.17	5.46
1800	43.06	89.19	1.33	2.13	33.30	35.62	45.04	5.49
1900	43.22	88.46	1.23	2.22	32.86	35.18	44.86	5.40
2000	43.48	90.60	1.14	2.21	32.34	34.54	44.46	5.53
2100	43.74	86.03	1.11	2.15	32.02	34.20	44.20	5.54
2200	44.10	88.05	1.18	2.02	31.68	33.91	43.80	5.48
2300	44.43	86.09	1.26	1.84	31.22	33.28	43.31	5.55
2400	44.58	85.04	1.33	1.61	30.81	32.96	42.89	5.60
2500	44.49	85.29	1.41	1.39	30.26	32.72	42.46	5.57
2600	44.28	84.42	1.51	1.24	30.33	32.82	42.53	5.48
2700	43.98	84.65	1.64	1.24	30.93	33.29	42.74	5.63
2800	43.77	84.11	1.76	1.32	31.30	33.42	42.54	5.54
2900	43.62	86.51	1.81	1.42	30.63	32.57	42.61	5.63
3000	43.53	84.85	1.78	1.48	29.93	31.26	42.15	5.75
3100	43.49	87.22	1.69	1.52	30.04	31.60	41.91	5.68
3200	43.50	86.44	1.59	1.51	30.42	32.26	41.92	5.77
3300	43.42	86.89	1.52	1.47	30.67	33.08	42.25	5.98
3400	43.26	87.77	1.50	1.42	30.96	33.33	42.58	5.91
3600	43.46	89.07	1.40	1.30	30.77	32.98	42.22	6.08
3800	44.16	85.54	1.23	1.10	30.46	32.46	42.06	6.23
4000	44.20	88.32	1.12	1.12	30.32	32.52	41.14	6.37
4200	43.64	85.08	1.13	1.18	29.96	32.68	40.84	6.35

## Typical Performance Curves

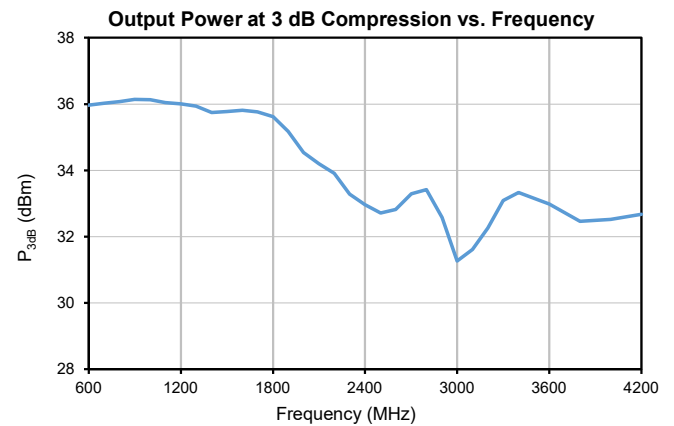
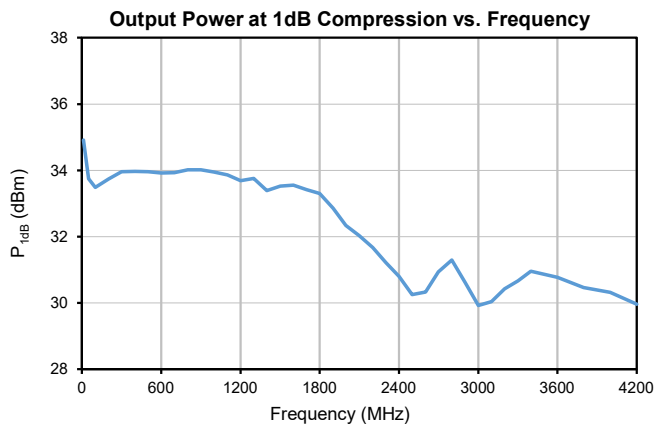
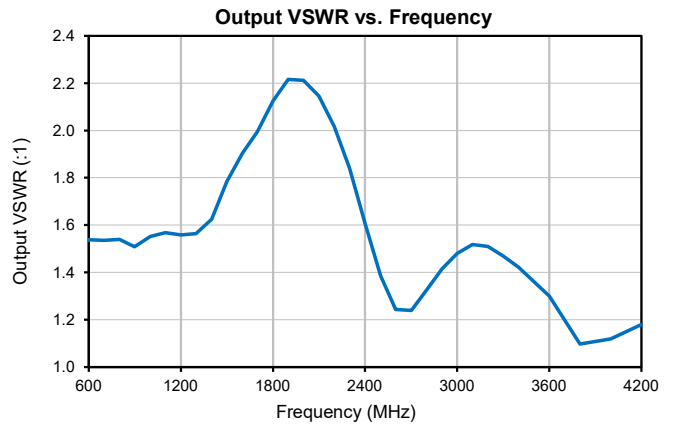
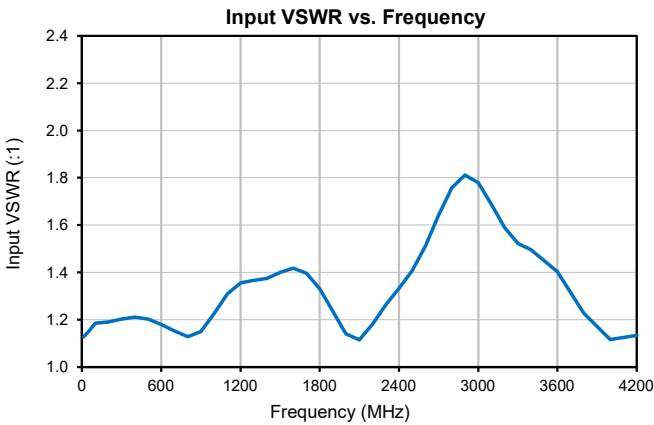
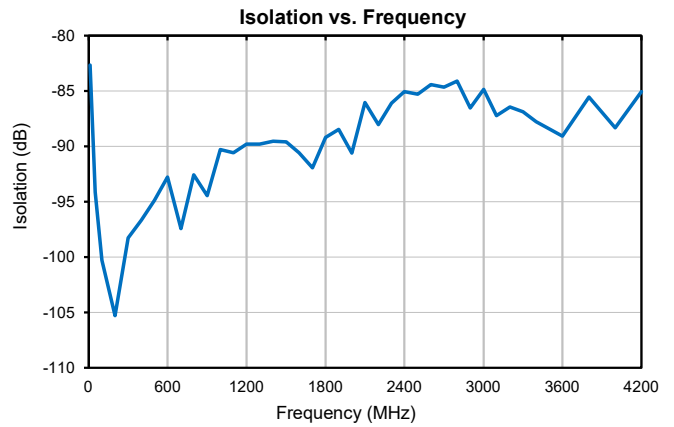
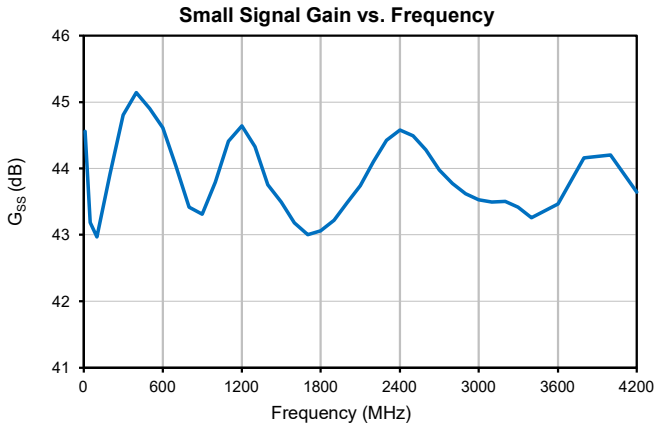

## Typical Performance Curves

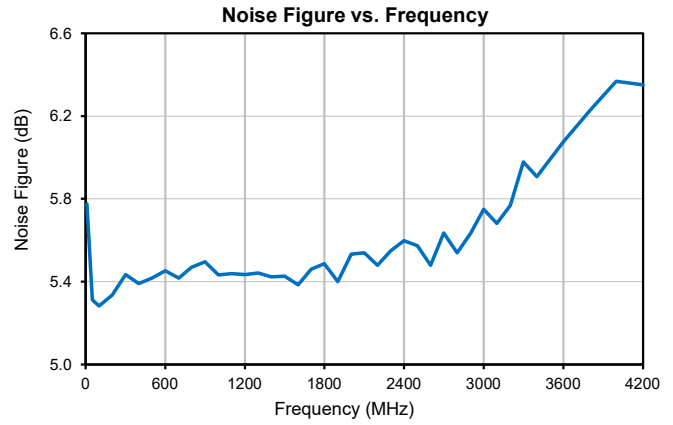
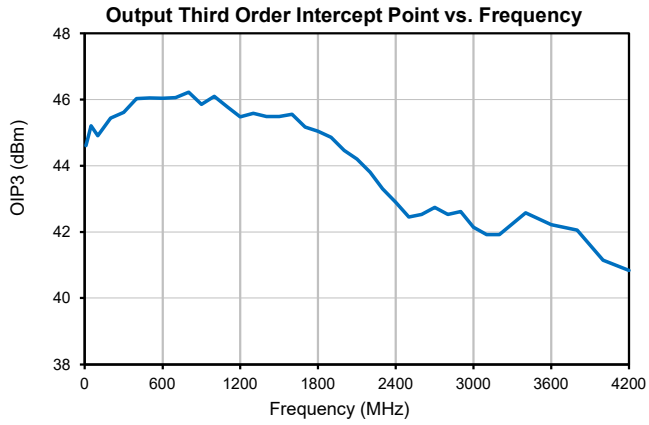



# Case Style

# PJ

## Outline Dimensions

## PJ2059-1

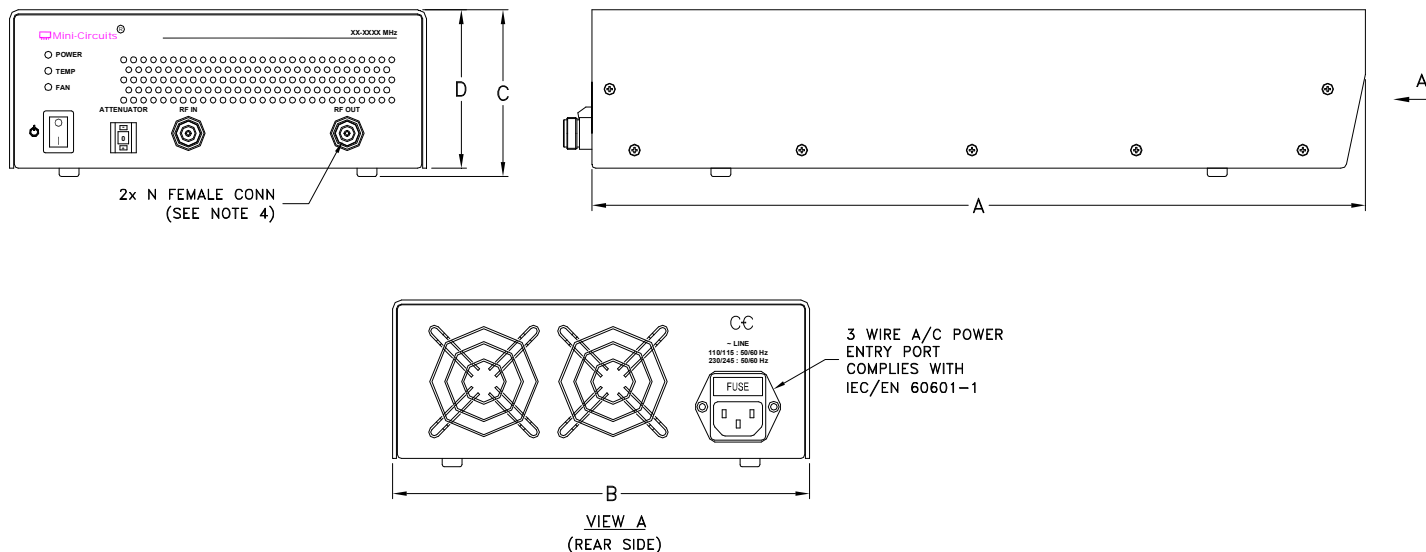

CASE#	A	B	C	D	E	WT, GRAM
PJ2059-1	15.35 (390.0)	8.27 (210.0)	3.25 (82.6)	3.09 (78.5)	-- --	3550

Dimensions are in inches (mm). Tolerances: 2 Pl.  $\pm .03$ ; 3 Pl.  $\pm .015$

### Notes:

1. Case material: Aluminum alloy.
2. Finish: White paint.
3. Keep area adjacent to airvents clear to allow free air flow. Caution: Do not insert anything, especially conductors or fingers into case opening. Physical injury, shock or death may occur.
4. Connector shape may vary.

**Mini-Circuits®**

INTERNET <http://www.minicircuits.com>

P.O. Box 350166, Brooklyn, New York 11235-0003 (718) 934-4500 Fax (718) 332-4661

Distribution Centers NORTH AMERICA 800-654-7949 • 417-335-5935 • Fax 417-335-5945 • EUROPE 44-1252-832600 • Fax 44-1252-837010

Mini-Circuits ISO 9001 & ISO 14001 Certified



All Mini-Circuits products are manufactured under exacting quality assurance and control standards, and are capable of meeting published specifications after being subjected to any or all of the following physical and environmental test.

Specification	Test/Inspection Condition	Reference/Spec
Operating Temperature	-0° to 55° C Ambient Environment	Individual Model Data Sheet
Storage Temperature	-40° to 70° C Ambient Environment	Individual Model Data Sheet