



COAXIAL

Medium Power Amplifier

ZHL-10M4G21W0+
ZHL-10M4G21W0X+

Mini-Circuits

50Ω 10 to 4200 MHz Broadband 1.6W SMA-Female

THE BIG DEAL

- Broadband, 10 to 4200MHz
- High Gain, 37dB typ.
- High P1dB, +32dBm, typ.
- High OIP3, +44dBm typ.



With heatsink

Without heatsink

Generic photo used for illustration purposes only

APPLICATIONS

- Communication Systems
- R&D, Production, and OTA Test Systems
- Test & Measurement Equipment
- General Laboratory Applications

FUNCTIONAL DIAGRAM

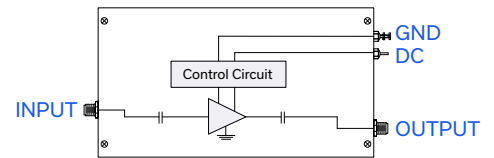

PRODUCT OVERVIEW

The ZHL-10M4G21W0(X)+ is a medium power broadband amplifier providing more than 1W of output power with a typical small signal gain of 37dB over the 10 to 4200 MHz frequency band. The amplifier uses state-of-the-art semiconductor technology and can be used in a wide range of applications. A single supply voltage ensures ease of operation. The amplifier is made with a rugged aluminum housing and can be supplied with or without a heatsink.

KEY FEATURES

Features	Advantages
Extremely Broadband, 10 to 4200 MHz and High Power, 1.6W	One single amplifier that covers the entire frequency band delivering rated power.
High Gain, 37 dB Typ.	High gain allows low drive levels to achieve rated output power which can be obtained from many standard lab generators.
Rugged by design	Accidental reversing of the polarity of the power supply or accidental open/short (delivering P _{1dB} power) will not damage the amplifier.
High OIP3, +44 dBm Typ.	High OIP3 makes the amplifier suitable for applications requiring high linearity such as digitally modulated signals.
Rugged enclosure	The solid aluminum enclosure makes the amplifier usable for any application from industrial, to laboratory environments.

REV. OR
ECO-017275
ZHL-10M4G21W0+
MCL NY
250228





COAXIAL

Medium Power Amplifier

ZHL-10M4G21W0+
ZHL-10M4G21W0X+

Mini-Circuits

50Ω 10 to 4200 MHz Broadband 1.6W SMA-Female

ELECTRICAL SPECIFICATIONS AT $T_{MOUNTINGBASE} = +25^{\circ}C, V_{DC} = +28V$

Parameter	Symbol	Condition	Min.	Typ.	Max.	Units
Frequency Range	f		10		4200	MHz
Small Signal Gain	G_{SS}		31	37	40	dB
Small Signal Gain Flatness	$G_{SS-FLAT}$			± 1.2	± 1.6	dB
Output Power at 1dB compression	P_{1dB}		28	32		dBm
Output Power at 3dB compression	P_{3dB}		29	34		dBm
Noise Figure	NF			6.5		dB
Output Third Order Intercept Point	OIP3	$P_{OUT} = +20dBm/ tone$		44		dBm
Input VSWR	I-VSWR			1.3	2.4	:1
Output VSWR	O-VSWR			1.5	2.4	:1
DC Supply Voltage	V_{DC}		26	28	30	V
Supply Current	I_{DC}	@ P_{3dB}		0.8	1.0	A



COAXIAL

Medium Power Amplifier

ZHL-10M4G21W0+
ZHL-10M4G21W0X+

Mini-Circuits

50Ω 10 to 4200 MHz Broadband 1.6W SMA-Female

TYPICAL PERFORMANCE DATA AT $T_{MOUNTINGBASE} = 25^{\circ}C, V_{DC} = 28V, 50 OHM$

Small Signal Gain vs. Frequency

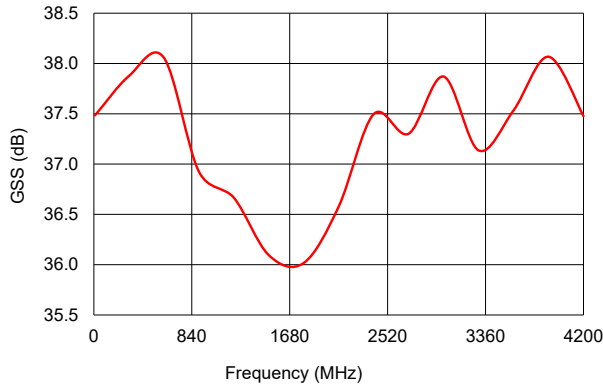

VSWR vs. Frequency

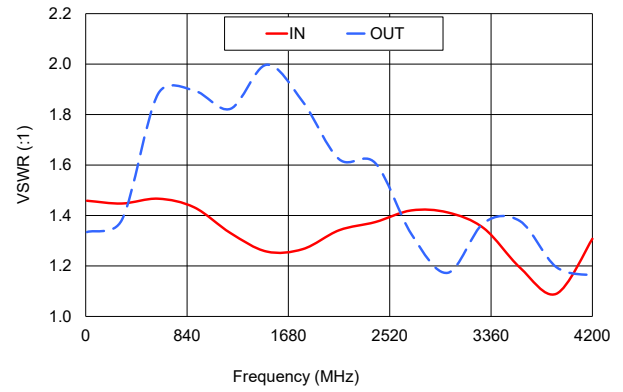

Output Power at 1dB Compression vs. Frequency

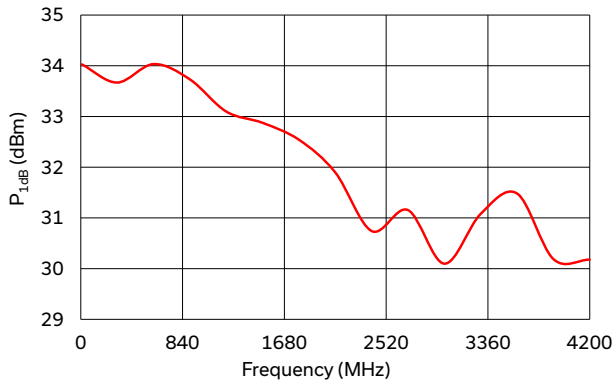

Output Power at 3dB Compression vs. Frequency

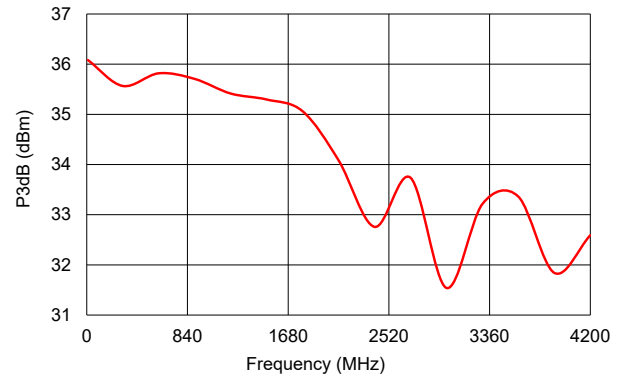

Noise Figure vs. Frequency

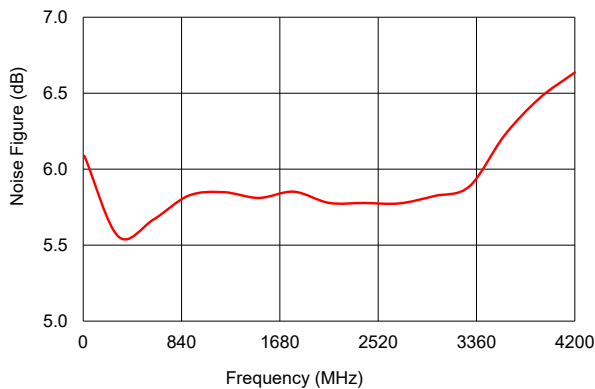

Output Third Order Intercept Point vs. Frequency

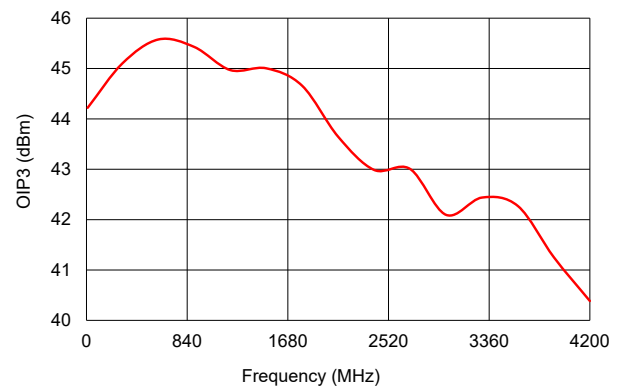



COAXIAL

Medium Power Amplifier

ZHL-10M4G21W0+
ZHL-10M4G21W0X+

Mini-Circuits

50Ω 10 to 4200 MHz Broadband 1.6W SMA-Female

ABSOLUTE MAXIMUM RATINGS

Parameter	Ratings	
Operating Temperature	ZHL-10M4G21W0+	T _{AMBIENT} : -20 °C to +65 °C
	ZHL-10M4G21W0X+	T _{MOUNTINGBASE} : -20 °C to +85 °C
Storage Temperature	-55 °C to +100 °C	
No damage with an open or short at P _{OUT} = +30 dBm CW for 2 minutes max		
RF Input Power (no damage)	+5 dBm	
DC Operating Voltage	± 30 V	

Permanent damage may occur if any of these limits are exceeded.

DETERMINING MAXIMUM THERMAL RESISTANCE OF USERS' EXTERNAL HEAT SINK

$\text{MAXIMUM THERMAL RESISTANCE} = \frac{\text{MAXIMUM OPERATING CASE TEMP} - \text{MAXIMUM USER AMBIENT TEMP}}{\text{POWER DISSIPATION}}$
<p>Example:</p> <p>MAXIMUM MOUNTING BASE TEMP = +85 °C (CHECK MAXIMUM RATINGS TABLE FOR THIS VALUE) MAXIMUM USER AMBIENT TEMP = +65 °C (USER DEFINED) POWER DISSIPATION = 30 WATTS (CHECK MAXIMUM RATINGS TABLE FOR THIS VALUE) THEN MAXIMUM ALLOWABLE THERMAL RESISTANCE = 0.66 °C/W</p>



COAXIAL

Medium Power Amplifier

ZHL-10M4G21W0+ ZHL-10M4G21W0X+

Mini-Circuits

50Ω 10 to 4200 MHz Broadband 1.6W SMA-Female

COAXIAL CONNECTIONS

IN (RF IN)	SMA-Female
OUT (RF OUT)	SMA-Female

CASE STYLE DRAWING WITH HEATSINK (ZHL-10M4G21W0+)

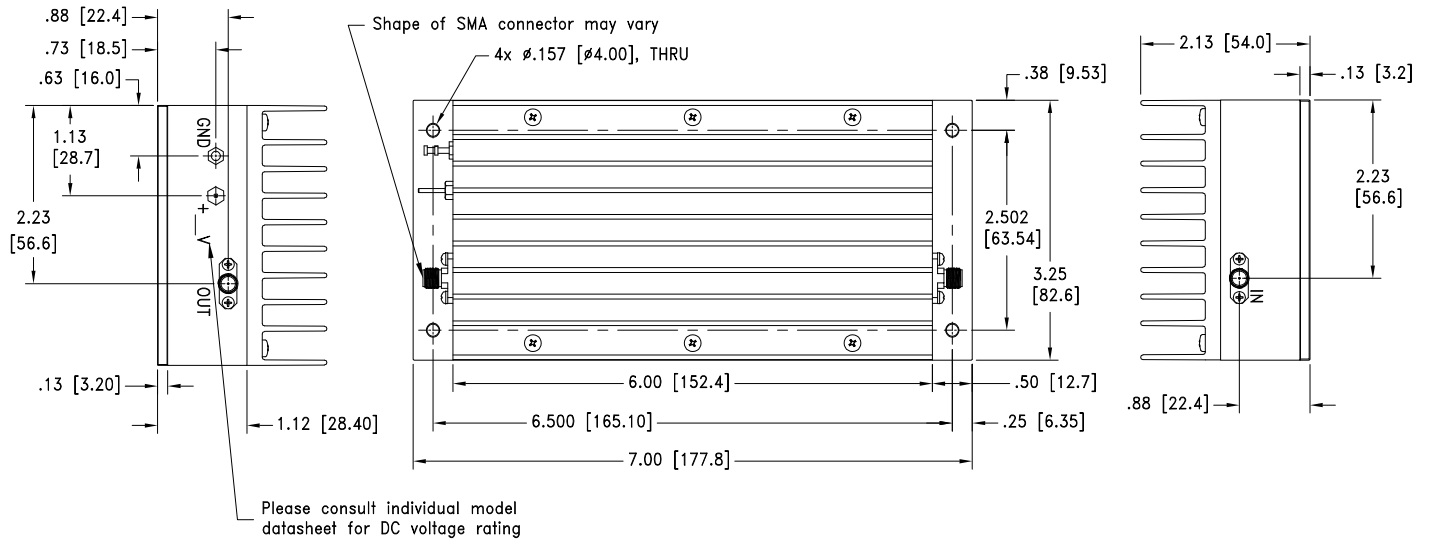

CASE STYLE DRAWING WITHOUT HEATSINK (ZHL-10M4G21W0X+)

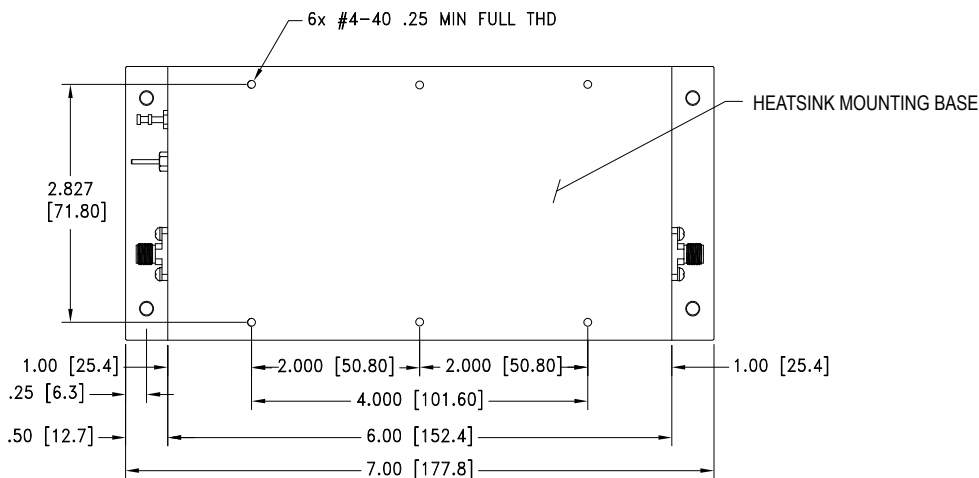

Weight: 900.0 grams. Weight without heatsink: 600.0 grams
 Dimensions are in inches [mm]. Tolerances: 2 Pl. \pm .03; 3 Pl. \pm .015 Inch





COAXIAL

Medium Power Amplifier

ZHL-10M4G21W0+
ZHL-10M4G21W0X+

Mini-Circuits

50Ω 10 to 4200 MHz Broadband 1.6W SMA-Female

ADDITIONAL INFORMATION IS AVAILABLE ON OUR DASHBOARD.

Performance Data	Table
	Graphs
	S-Parameter (S2P Files) Data Set (.zip file)
RoHs Status	Compliant
Environmental Ratings	ENV23T3

ORDERING INFORMATION

Model No. Links	ZHL-10M4G21W0+	ZHL-10M4G21W0X+
Option	With heatsink	Without heatsink
Case Style	U36	
Connector	IN (SMA-Female) / OUT (SMA-Female)	

NOTES

- A. Performance and quality attributes and conditions not expressly stated in this specification document are intended to be excluded and do not form a part of this specification document.
- B. Electrical specifications and performance data contained in this specification document are based on Mini-Circuit's applicable established test performance criteria and measurement instructions.
- C. The parts covered by this specification document are subject to Mini-Circuits standard limited warranty and terms and conditions (collectively, "Standard Terms"); Purchasers of this part are entitled to the rights and benefits contained therein. For a full statement of the standard terms and the exclusive rights and remedies thereunder, please visit Mini-Circuits' website at www.minicircuits.com/terms/viewterm.html



Typical Performance Data

FREQUENCY (MHz)	GAIN (dB) 28V	ISOLATION (dB) 28V	VSWR (:1)		P _{OUT} @ 1 dB COMPRESSION (dBm) 28V	P _{OUT} @ 3 dB COMPRESSION (dBm) 28V	P _{OUT} at SATURATION (dBm) 28V	OIP3 (dBm) 28V
			IN 28V	OUT 28V				
10	37.48	91.21	1.46	1.33	34.0	36.1	36.9	44.2
50	36.33	106.13	1.44	1.45	33.5	35.5	36.3	44.8
100	36.24	113.54	1.44	1.27	33.2	35.1	36.0	44.3
200	37.07	107.22	1.45	1.22	33.3	35.3	36.3	44.8
300	37.87	103.02	1.45	1.38	33.7	35.6	36.8	45.1
400	37.91	100.56	1.45	1.46	33.6	35.5	36.8	45.2
500	38.18	97.46	1.46	1.73	34.0	35.9	37.2	45.5
600	38.06	96.56	1.47	1.88	34.0	35.8	37.1	45.6
700	37.71	95.69	1.46	1.90	33.9	35.8	36.9	45.5
800	37.15	95.45	1.45	1.84	33.9	35.7	36.8	45.4
900	36.93	94.97	1.43	1.90	33.7	35.7	36.7	45.4
1000	36.84	94.42	1.40	1.88	33.6	35.7	36.6	45.5
1100	36.82	93.74	1.36	1.84	33.2	35.5	36.4	45.0
1200	36.67	93.27	1.33	1.82	33.1	35.4	36.2	45.0
1300	36.42	92.48	1.30	1.88	32.8	35.2	36.0	44.6
1400	36.23	92.16	1.28	2.01	32.9	35.3	36.1	44.7
1500	36.10	91.86	1.26	2.00	32.9	35.3	36.0	45.0
1600	35.97	90.93	1.25	1.96	32.6	35.1	35.8	44.6
1700	35.92	90.57	1.25	1.93	32.8	35.3	35.8	44.7
1800	36.02	89.75	1.27	1.85	32.5	35.1	35.7	44.7
1900	36.10	89.21	1.29	1.74	32.1	34.5	35.3	43.9
2000	36.20	88.74	1.32	1.63	32.1	34.2	35.1	44.0
2100	36.58	87.76	1.34	1.62	31.9	34.1	35.2	43.6
2200	37.05	86.98	1.36	1.61	31.8	33.9	35.2	43.5
2300	37.42	86.11	1.37	1.65	31.2	33.3	35.0	43.1
2400	37.50	85.76	1.37	1.61	30.7	32.8	34.8	43.0
2500	37.38	85.67	1.38	1.54	31.1	33.0	35.1	43.0
2600	37.23	85.39	1.40	1.43	30.8	33.1	35.3	43.0
2700	37.30	85.31	1.42	1.33	31.2	33.7	35.5	43.0
2800	37.47	84.81	1.43	1.25	31.5	33.7	35.4	43.2
2900	37.71	84.69	1.43	1.18	30.8	32.4	35.1	42.7
3000	37.87	84.67	1.41	1.17	30.1	31.5	34.7	42.1
3100	37.79	84.78	1.39	1.19	29.8	31.7	34.5	41.5
3200	37.47	85.13	1.37	1.28	30.6	32.7	34.5	42.1
3300	37.14	85.69	1.35	1.37	31.1	33.2	34.6	42.4
3400	36.97	86.01	1.32	1.44	31.2	33.4	34.6	42.4
3600	37.53	86.22	1.19	1.38	31.5	33.4	34.5	42.3
3800	38.14	85.86	1.05	1.20	30.7	32.1	33.6	41.6
4000	37.89	86.85	1.16	1.18	29.9	31.7	33.5	40.5
4200	37.48	86.13	1.31	1.16	30.2	32.6	34.3	40.4

Typical Performance Curves

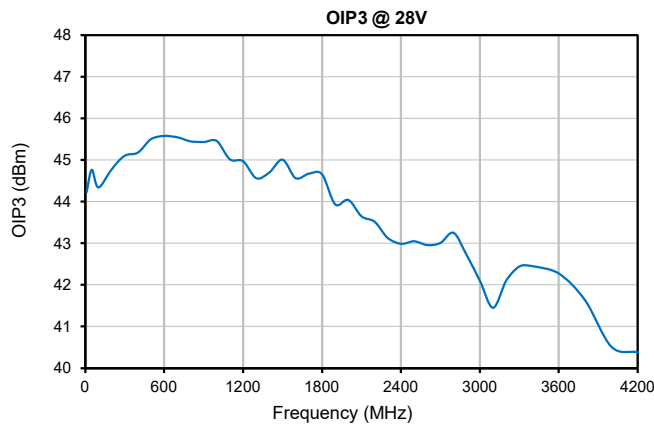
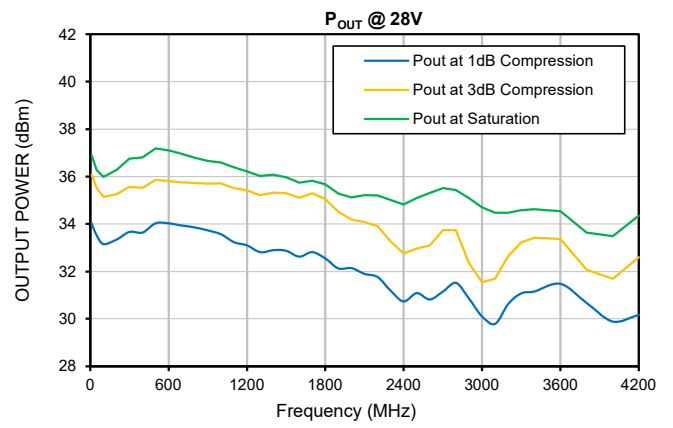
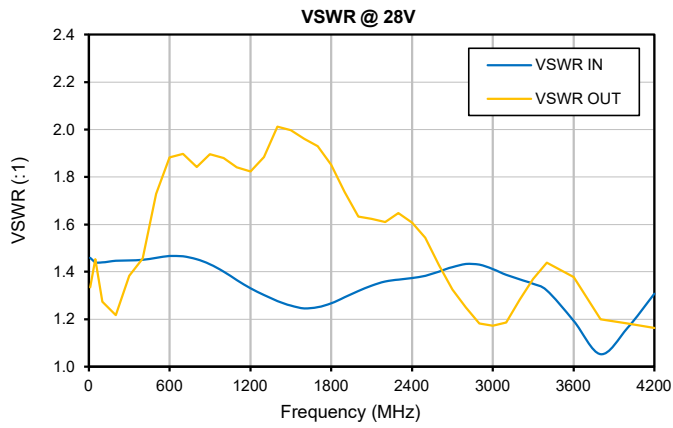
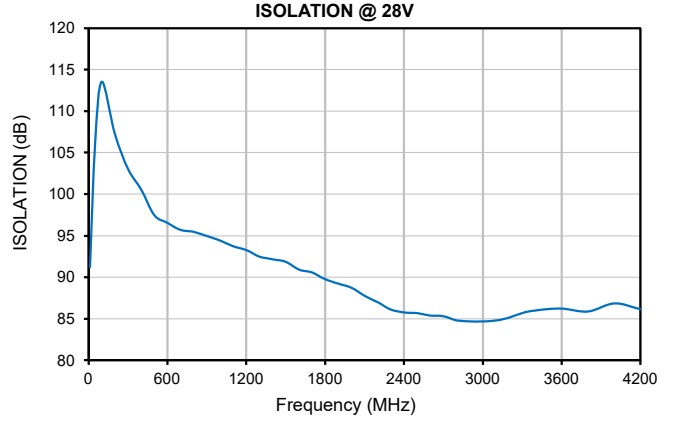
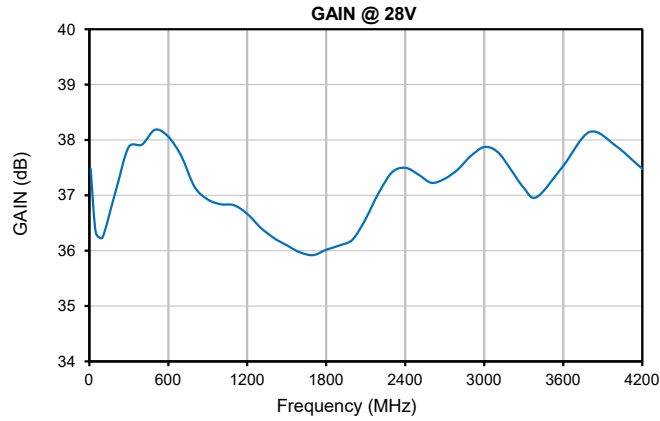

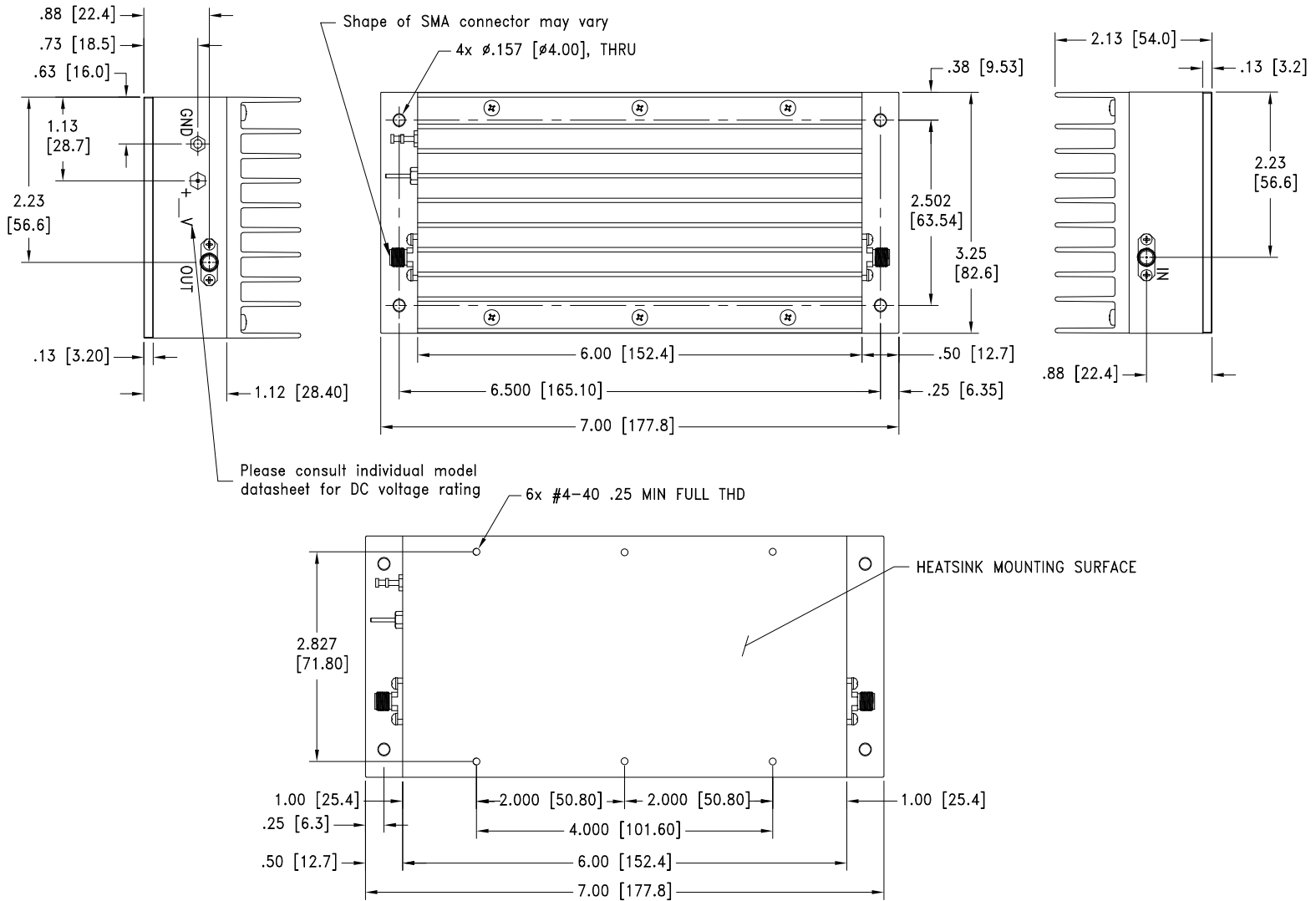

MOUNTING INFORMATION FOR MODELS WITHOUT HEATSINK

Weight: 900.0 grams Weight without heatsink: 600.0 grams

Dimensions are in inches [mm]. Tolerances: 2 Pl. \pm 03; ; 3 Pl. \pm .015 Inch

Notes:

- Case material: Aluminum alloy.
- Case finish and mounting bracket finish:
For RoHS Case Styles: Clear chemical conversion coating, non-chrome or trivalent chrome based.

For Non-RoHS Case Styles: Yellow hexavalent chrome based conversion coating.
Due to transition from non-RoHS to RoHS, models will be supplied with either case style finish until the non-RoHS case inventory is depleted.

- Heat sink finish: Black anodize.



P.O. Box 350166, Brooklyn, New York 11235-0003 (718) 934-4500 Fax (718) 332-4661 For detailed performance specs & shopping online see Mini-Circuits web site



The Design Engineers Search Engine Provides ACTUAL Data Instantly From MINI-CIRCUITS At: www.minicircuits.com

RF/IF MICROWAVE COMPONENTS

All Mini-Circuits products are manufactured under exacting quality assurance and control standards, and are capable of meeting published specifications after being subjected to any or all of the following physical and environmental test.

Specification	Test/Inspection Condition	Reference/Spec
Operating Temperature	-20° to 65° C Ambient Environment	Individual Model Data Sheet
Storage Temperature	-55° to 100° C Ambient Environment	Individual Model Data Sheet
Stabilization Bake	(non-operating) 125°C, 24 hours	- - -
Burn-in at Elevated Temp.	(DC on) 160 hours at 85° C	MIL-STD-202, Method 108
Thermal Shock	-55° to 100°C, 5 cycles	MIL-STD-202, Method 107, Condition A, except 100°C