



COAXIAL

# Medium High Power Amplifier

# ZHL-1042J+ ZHL-1042JX+

50Ω 10 to 4200 MHz

## FEATURES

- Wideband, 10 to 4200 MHz
- High IP3, +35 dBm typ.
- Low noise, 6 dB min.

## APPLICATIONS

- Communication Systems
- Laboratory

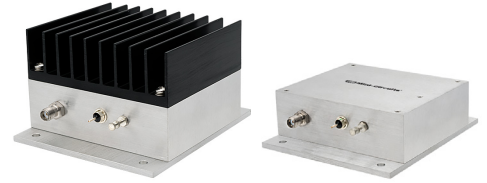

Generic photo used for illustration purposes only

Model No.	ZHL-1042J+	ZHL-1042JX+ <sup>▲</sup>
Case Style	NN92	
Connectors	SMA	

**+RoHS Compliant**  
 The +Suffix identifies RoHS Compliance.  
 See our website for methodologies and qualifications

## ELECTRICAL SPECIFICATIONS AT 25°C

Parameter	Condition (MHz)	ZHL-1042J+ ZHL-1042JX+ <sup>▲</sup>			Units
		Min.	Typ.	Max.	
Frequency Range		10	—	4200	MHz
Gain	10-4200	24	27	32	dB
Gain Flatness	10-4200	—	±1.2	±1.7	dB
Output Power at 1dB compression	10-4200	+20	+22	—	dBm
Output Power at 3dB compression	10-4200	+21	+23	—	dBm
Noise Figure	10-4200	—	6.0	—	dB
Output third order intercept point	10-4200	—	+35	—	dBm
Input VSWR	10-4200	—	—	2.5	:1
Output VSWR	10-4200	—	—	2.5	:1
DC Supply Voltage		—	15	—	V
Supply Current		—	—	0.330	A

Open load is not recommended, potentially can cause damage. With no load derate max. input power by 20 dB.

<sup>▲</sup> Heat sink not included. Alternative heat sinking and heat removal must be provided by the user to limit maximum base-plate temperature to 65°C, in order to ensure proper performance. For reference, this requires thermal resistance of user's external heat sink to be 2.2°C/W max.

## ABSOLUTE MAXIMUM RATINGS

Parameter	Ratings
Operating Temperature	-20°C to +65°C
Storage Temperature	-55°C to +100°C
DC Voltage	+20V
Input RF Power (no damage)	+10 dBm

Permanent damage may occur if any of these limits are exceeded.





COAXIAL

# Medium High Power Amplifier

## ZHL-1042J+ ZHL-1042JX+

50Ω 10 to 4200 MHz

### OUTLINE DRAWING FOR MODELS WITH HEATSINK

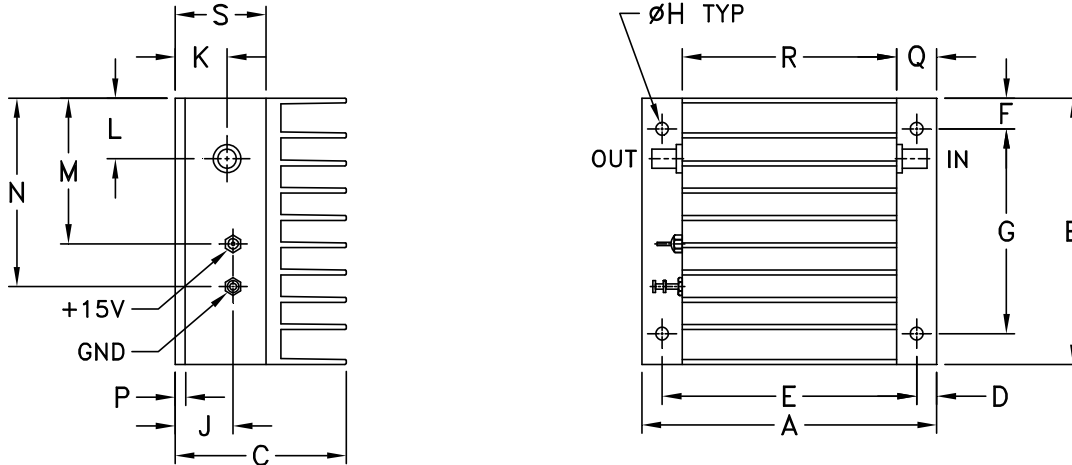

### MOUNTING INFORMATION FOR MODELS WITHOUT HEATSINK

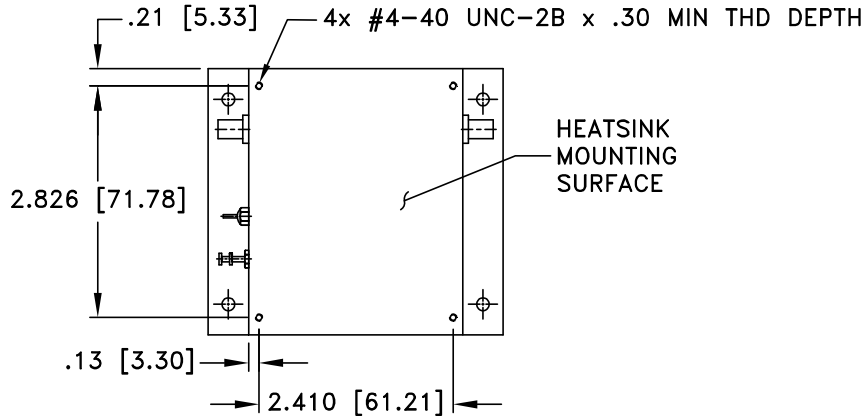

### OUTLINE DIMENSIONS (Inch/mm)

A	B	C	D	E	F	G	H	J	K	L	M	N	P	Q	R	S	wt
3.66	3.25	2.13	.25	3.16	.38	2.50	.156	.72	.64	.74	1.78	2.30	.125	.50	2.66	1.13	grams*
92.96	82.55	54.10	6.35	80.26	9.65	63.50	3.96	18.29	16.26	18.80	45.21	58.42	3.18	12.70	67.56	28.7	500.0
																	*362 grams without heatsink





COAXIAL

# Medium High Power Amplifier

# ZHL-1042J+ ZHL-1042JX+

50Ω 10 to 4200 MHz

### TYPICAL PERFORMANCE DATA/CURVES

FREQUENCY (MHz)	GAIN (dB)	DIRECTIVITY (dB)	VSWR (:1)		POUT at 1 dB COMPR. (dBm)	NOISE FIGURE (dB)	IP3 (dBm)
	15V	15V	IN	OUT	15V	15V	15V
10	27.79	29.01	2.29	2.11	23.20	5.21	33.56
300	28.09	18.28	1.56	1.67	23.35	4.10	38.81
600	27.78	18.55	1.65	1.38	22.89	4.11	40.42
900	27.83	18.03	1.62	1.12	22.78	4.15	42.12
1200	28.19	16.76	1.49	1.19	23.51	4.27	45.58
1500	28.50	15.16	1.45	1.52	24.25	4.35	49.14
1800	28.22	14.69	1.46	1.84	24.02	4.53	46.70
2100	27.95	14.64	1.37	1.94	24.20	4.60	44.94
2400	27.58	14.89	1.38	1.77	24.62	4.72	48.99
2700	27.21	15.26	1.55	1.51	24.31	4.79	47.16
3000	26.86	15.57	1.59	1.48	24.21	4.83	43.89
3300	26.61	15.50	1.36	1.61	24.24	4.96	42.27
3600	26.79	15.54	1.03	1.59	24.03	4.96	41.05
3900	26.67	16.18	1.28	1.39	23.59	4.97	39.79
4200	26.56	17.35	1.21	1.28	22.48	5.01	38.07

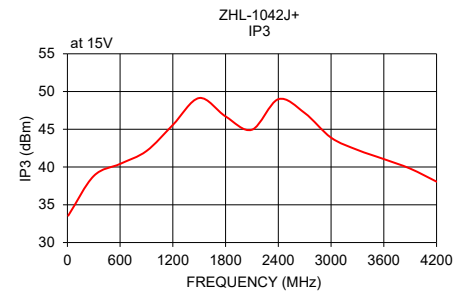
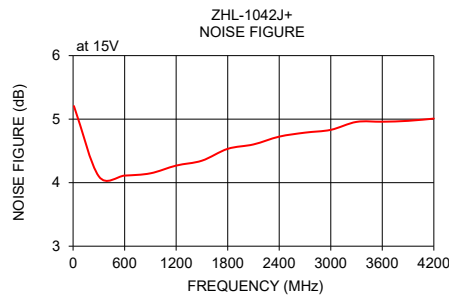
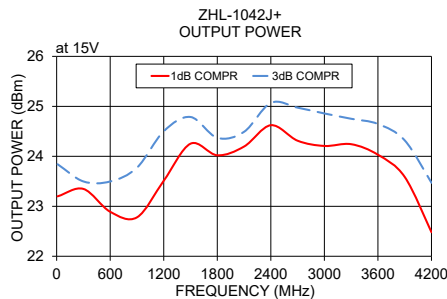
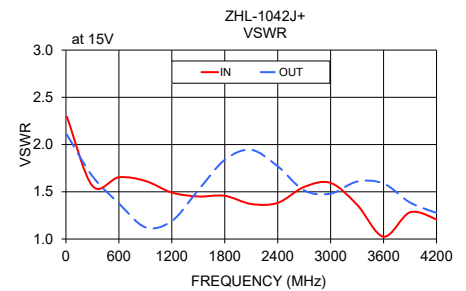
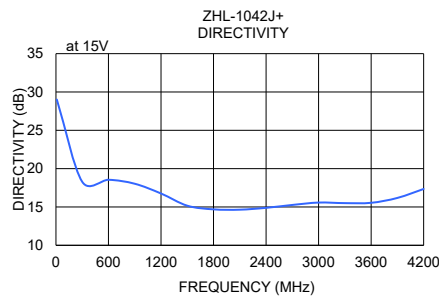
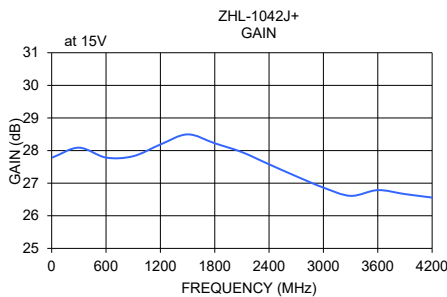

#### NOTES

- A. Performance and quality attributes and conditions not expressly stated in this specification document are intended to be excluded and do not form a part of this specification document.
- B. Electrical specifications and performance data contained in this specification document are based on Mini-Circuit's applicable established test performance criteria and measurement instructions.
- C. The parts covered by this specification document are subject to Mini-Circuits standard limited warranty and terms and conditions (collectively, "Standard Terms"); Purchasers of this part are entitled to the rights and benefits contained therein. For a full statement of the standard terms and the exclusive rights and remedies thereunder, please visit Mini-Circuits' website at [www.minicircuits.com/terms/viewterm.html](http://www.minicircuits.com/terms/viewterm.html)



# Amplifier

# ZHL-1042J+

## Typical Performance Data

FREQ. (MHz)	GAIN (dB)			DIRECTIVITY (dB)			VSWR (:1)		NOISE FIGURE (dB) 15V	POUT @ 1 dB COMPRESSION (dBm) 15V
	12V	15V	16V	12V	15V	16V	IN 15V	OUT 15V		
10.0	27.55	28.68	28.68	33.40	32.60	33.80	1.60	1.57	19.14	22.32
21.4	28.01	29.08	29.09	30.70	19.80	26.40	1.56	1.83	17.99	23.20
67.0	27.31	28.36	28.37	28.30	27.70	27.50	1.57	1.84	13.37	22.82
209.9	27.41	28.43	28.44	32.30	29.80	34.40	1.52	1.78	7.36	22.75
258.5	26.30	27.16	27.18	29.70	23.10	24.80	1.65	1.10	5.34	21.04
657.2	27.06	28.06	28.06	29.80	23.00	30.50	1.24	1.43	5.90	21.80
1514.1	27.81	28.70	28.71	29.50	29.10	27.40	1.53	1.62	5.28	20.96
1836.4	27.53	28.29	28.28	30.00	26.70	27.70	1.88	1.47	5.40	21.14
2158.7	26.69	27.44	27.44	25.50	26.20	27.90	1.94	1.29	5.39	20.59
2373.6	26.44	27.26	27.27	25.00	26.00	28.50	1.83	1.20	5.30	20.84
2910.8	26.45	27.38	27.41	23.90	28.10	23.20	1.48	1.12	5.41	20.61
3233.1	26.74	27.60	27.60	23.50	31.50	25.70	1.45	1.34	5.43	20.72
3555.4	26.87	27.63	27.64	28.60	25.90	25.80	1.17	1.64	5.43	20.61
3877.7	27.26	28.14	28.15	22.20	20.80	22.20	1.31	1.75	5.55	21.22
4200.0	27.17	28.06	28.08	21.90	18.30	21.20	1.46	1.66	5.58	20.82



P.O. Box 350166, Brooklyn, New York 11235-0003 (718) 934-4500 • Fax (718) 332-4661 For detailed performance specs & shopping online see Mini-Circuits web site  
 The Design Engineers Search Engine Provides ACTUAL Data Instantly From MINI-CIRCUITS At: [www.minicircuits.com](http://www.minicircuits.com)



IF/RF MICROWAVE COMPONENTS

REV. OR  
 ZHL-1042J+  
 6/6/2013  
 Page 1 of 1

## Typical Performance Curves

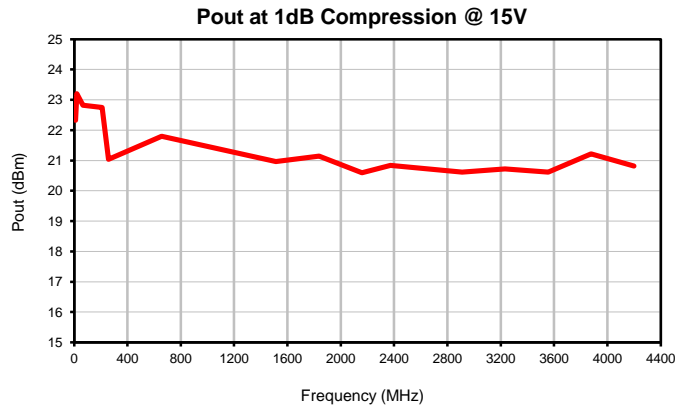
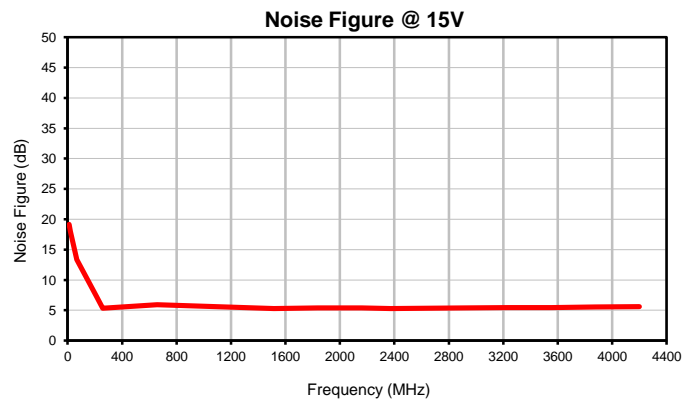
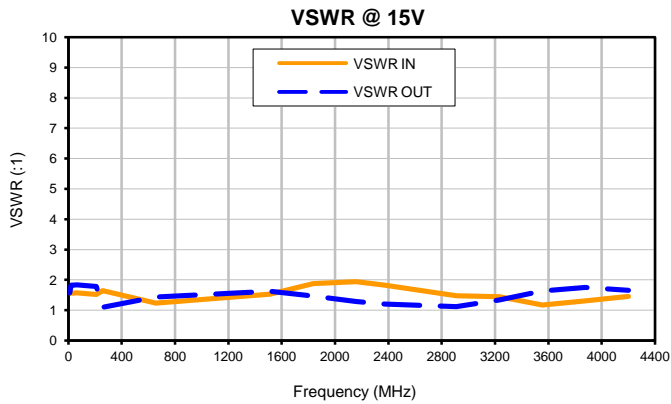
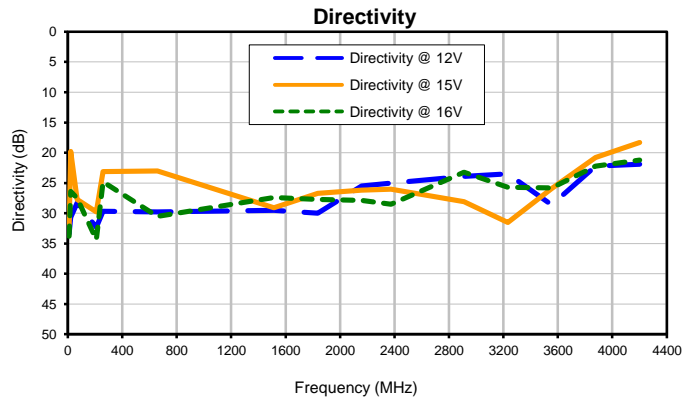
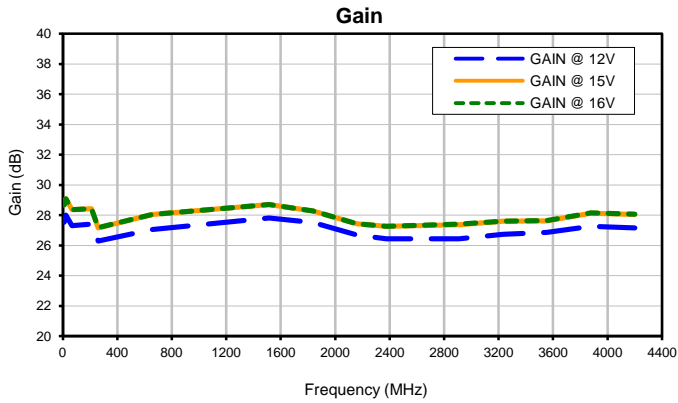

### Outline Dimensions

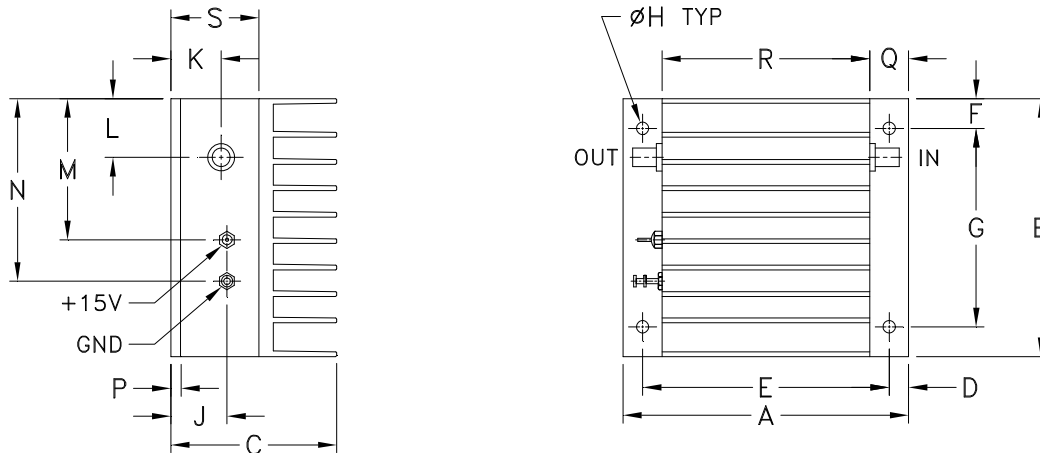

#### MOUNTING INFORMATION FOR MODELS WITHOUT HEATSINK

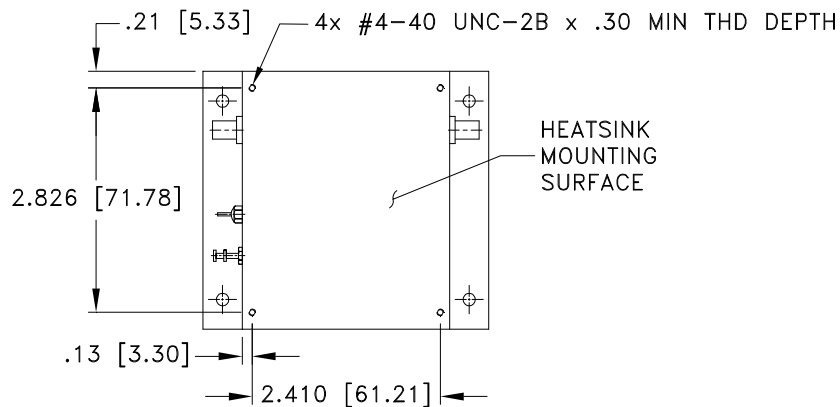

CASE#	A	B	C	D	E	F	G	H	J	K	L	M	N
NN92	3.66 (92.96)	3.25 (82.55)	2.13 (54.10)	.25 (6.35)	3.16 (80.26)	.38 (9.65)	2.50 (63.50)	.156 (3.96)	.72 (18.29)	.64 (16.26)	.74 (18.80)	1.78 (45.21)	2.30 (58.42)

CASE#	P	Q	R	S	WT. GRAMS	WT. WITHOUT HEATSINK GRAMS
NN92	.125 (3.18)	.50 (12.70)	2.66 (67.56)	1.13 (28.58)	500.0	362.0

Dimensions are in inches (mm). Tolerances: 2 Pl. + .03; 3 Pl. + .015

#### Notes:

- Case material: Aluminum alloy.
- Case and mounting bracket finish:  
For RoHS Case Styles: Clear chemical conversion coating, non-chrome or trivalent chrome based.
- Heat sink finish: Black anodize.

All Mini-Circuits products are manufactured under exacting quality assurance and control standards, and are capable of meeting published specifications after being subjected to any or all of the following physical and environmental test.

Specification	Test/Inspection Condition	Reference/Spec
Operating Temperature	-20° to 65° C Ambient Environment	Individual Model Data Sheet
Storage Temperature	-55° to 100° C Ambient Environment	Individual Model Data Sheet
Stabilization Bake	(non-operating) 125°C, 24 hours	- - -
Burn-in at Elevated Temp.	(DC on) 160 hours at 85° C	MIL-STD-202, Method 108
Thermal Shock	-55° to 100°C, 5 cycles	MIL-STD-202, Method 107, Condition A, except 100°C