



(LTCC) COAXIAL

# High Pass Filter

## ZHFW-K8400+

50Ω 9.2 to 18 GHz 2.92mm Female

### KEY FEATURES

- Low Insertion Loss, 1.4 dB Typ.
- Return Loss, 11 dB Typ.
- Stop Band Rejection, 44 dB Typ.
- Broadband Connectorized Package.
- Power Handling: 2.5 Watts.

### APPLICATIONS

- Test and Measurement Equipment.
- Military Applications.
- Telecommunications and Broadband Wireless systems.



Generic photo used for illustration purposes only

### PRODUCT OVERVIEW

ZHFW-K8400+ is a 50ohm high pass filter built in broad band connectorized package. Covering 9.2-18 GHz bandwidth, these units offer good matching within the passband and good rejection in stopband. ZHFW-K8400+ offer low insertion loss, and excellent power handling capability. It handles up to 2.5 W RF input power and provides a wide operating temperature range from -55°C to 125°C.

### FUNCTIONAL DIAGRAM

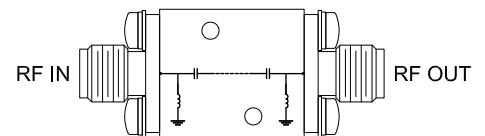

### ELECTRICAL SPECIFICATIONS<sup>1,2</sup> AT +25°C

Parameter		F#	Frequency (GHz)	Min.	Typ.	Max.	Units
Pass Band	Insertion Loss	F3-F4	9.2 - 11.5	—	2.0	—	dB
		F4-F5	11.5 - 17	—	1.4	2.2	
		F5-F6	17 - 18	—	1.4	—	
Pass Band	Return Loss	F3-F4	9.2 - 11.5	—	11	—	dB
		F4-F5	11.5 - 17	—	11	—	
		F5-F6	17 - 18	—	8	—	
Stop Band	Rejection	DC-F1	DC - 5.2	32	44	—	dB
		F1-F2	5.2 - 6.5	20	34	—	
	Freq. Cut-Off <sup>3</sup>	Fc <sup>3</sup>	8.4	—	3	—	dB

1. This filter is bi-directional, RF1 and RF2 ports may be interchanged, see S-Parameters for actual performance.

2. This component should not be used as a DC-block. In applications where DC voltage and/or current is present at either the input or output ports, external DC blocking capacitors are required.

3. Typical variation ± 5%

### ABSOLUTE MAXIMUM RATINGS<sup>4</sup>

Parameter	Ratings
Operating Temperature	-55 °C to +125 °C
Storage Temperature	-55 °C to +125 °C
Input Power <sup>5</sup>	2.5 W @25°C

4. Permanent damage may occur if any of these limits are exceeded.

5. Power rating applies only to signals within the passband. Power rating above +25°C operating temperature decreases linearly to 0.6W at +125°C.

### TYPICAL FREQUENCY RESPONSE

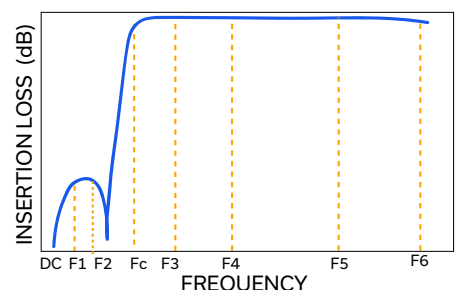



(LTCC) COAXIAL

# High Pass Filter

## ZHFW-K8400+

50Ω 9.2 to 18 GHz 2.92mm Female

### TYPICAL PERFORMANCE GRAPHS

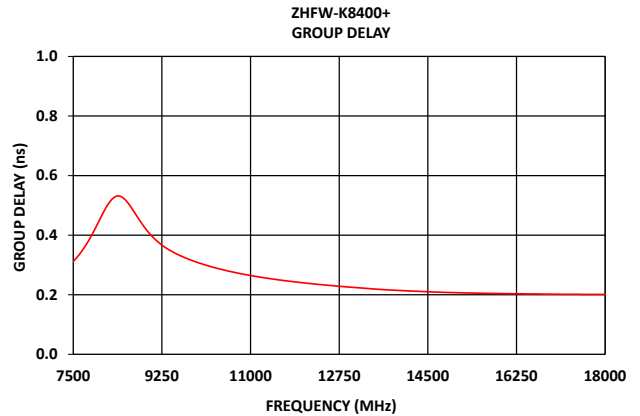
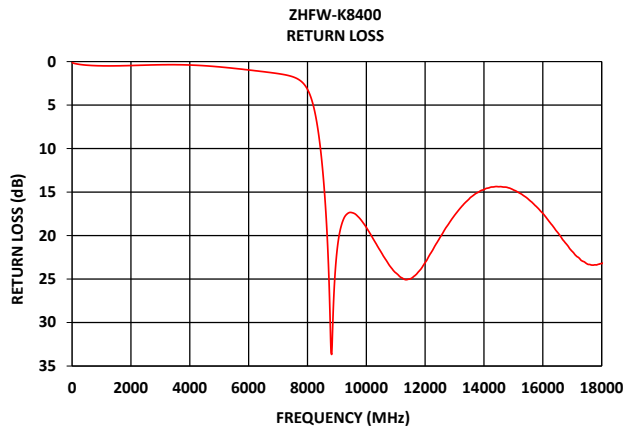
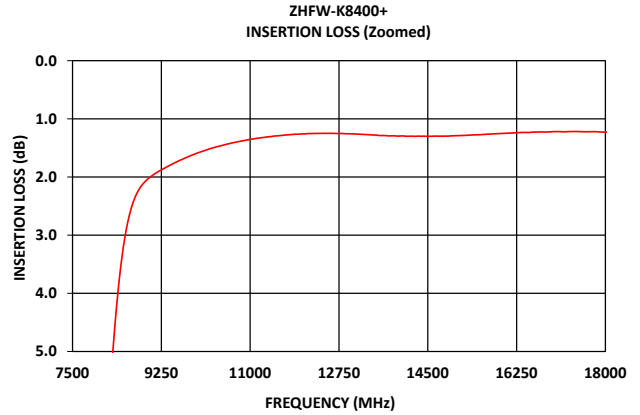
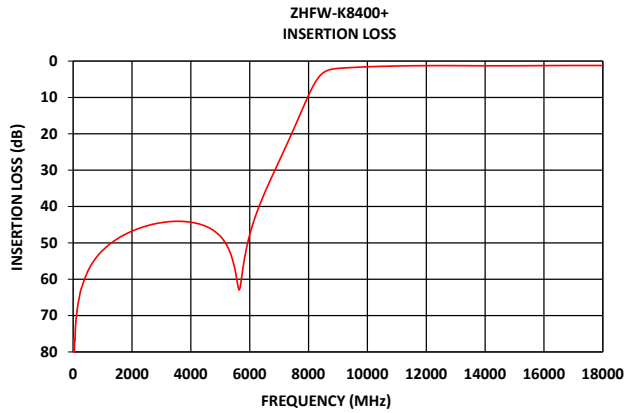



(LTCC) COAXIAL

# High Pass Filter

## ZHFW-K8400+

50Ω 9.2 to 18 GHz 2.92mm Female

### CONNECTOR DESCRIPTION

Function	Marking on Unit	Connector
RF1 <sup>1</sup>	1	2.92mm Female
RF2 <sup>1</sup>	2	2.92mm Female

### CASE STYLE DRAWING

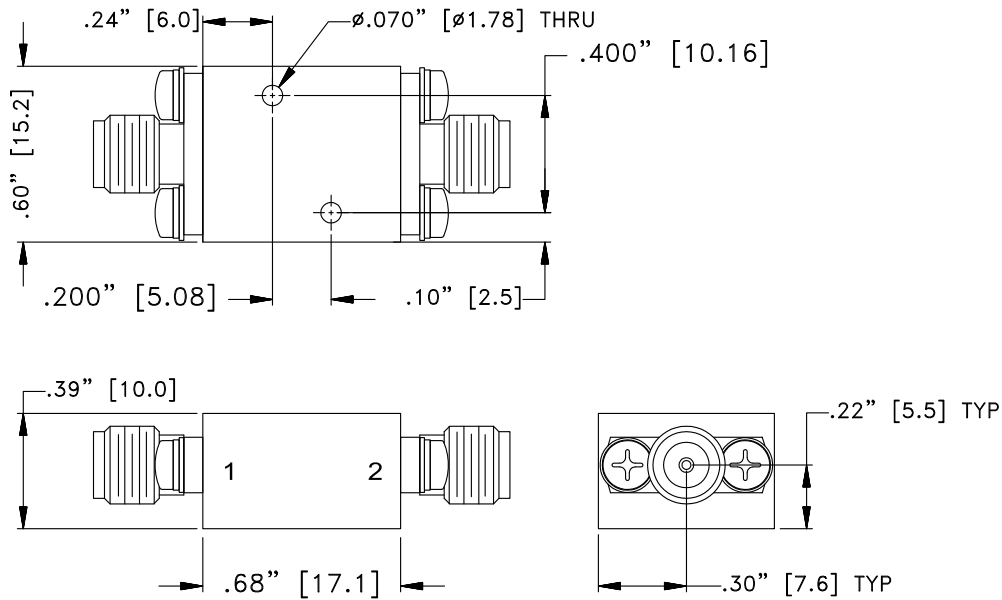

Unit weight: 24grams

Dimensions are in inches (mm). Tolerances: 2 Pl.±.050"; 3 Pl.±.015"

**PRODUCT MARKING\*:** ZHFW-K8400+

\*Marking may contain other features or characters for internal lot control.



(LTCC) COAXIAL

# High Pass Filter

## ZHFW-K8400+

50Ω 9.2 to 18 GHz 2.92mm Female

ADDITIONAL INFORMATION IS AVAILABLE ON OUR DASHBOARD

[CLICK HERE](#)

Performance Data & Graphs	<p>Data</p> <p>Graphs</p> <p>S-Parameter (S2P Files) Data Set (.zip file)</p>
Case Style	UK3042
RoHS Status	Compliant
Environmental Ratings	ENV124

### NOTES

- A. Performance and quality attributes and conditions not expressly stated in this specification document are intended to be excluded and do not form a part of this specification document.
- B. Electrical specifications and performance data contained in this specification document are based on Mini-Circuits' applicable established test performance criteria and measurement instructions.
- C. The parts covered by this specification document are subject to Mini-Circuits' standard limited warranty and terms and conditions (collectively, "Standard Terms"); Purchasers of this part are entitled to the rights and benefits contained therein. For a full statement of the standard terms and the exclusive rights and remedies thereunder, please visit Mini-Circuits' website at [www.minicircuits.com/terms/viewterm.html](http://www.minicircuits.com/terms/viewterm.html)



# Coaxial High Pass Filter

# ZHFW-K8400

## Typical Performance Data

FREQ.	Insertion Loss	Input Return Loss	Output Return Loss	FREQ.	Group Delay
(MHz)	(dB)	(dB)	(dB)	(MHz)	(ns)
10	79.16	0.12	0.11	9400	0.35
20	76.30	0.14	0.13	9500	0.34
40	80.38	0.17	0.16	9600	0.33
50	76.99	0.18	0.17	9700	0.32
80	72.77	0.21	0.21	9800	0.32
100	71.02	0.23	0.23	9900	0.31
150	67.63	0.26	0.27	10000	0.31
200	65.40	0.29	0.31	10200	0.30
250	63.28	0.32	0.33	10400	0.29
350	60.83	0.36	0.38	10600	0.28
450	58.75	0.40	0.41	10800	0.27
550	56.99	0.42	0.44	11000	0.26
650	55.61	0.45	0.46	11200	0.26
750	54.41	0.46	0.48	11400	0.25
850	53.38	0.47	0.50	11600	0.25
950	52.50	0.48	0.51	11800	0.24
1000	52.08	0.49	0.51	12000	0.24
1200	50.63	0.49	0.53	12200	0.24
1400	49.43	0.49	0.53	12400	0.23
1600	48.39	0.48	0.52	12600	0.23
1800	47.52	0.47	0.51	12800	0.23
1400	49.43	0.49	0.53	13000	0.23
1500	48.91	0.49	0.53	13200	0.22
1600	48.39	0.48	0.52	13400	0.22
1700	47.96	0.48	0.52	13600	0.22
1800	47.52	0.47	0.51	13800	0.22
1900	47.14	0.46	0.51	14000	0.21
2000	46.77	0.45	0.49	14200	0.21
2500	45.33	0.40	0.44	14400	0.21
3000	44.44	0.37	0.39	14600	0.21
3500	44.06	0.36	0.37	14800	0.21
4000	44.33	0.39	0.39	15000	0.21
4500	45.41	0.48	0.47	15100	0.21
5000	48.15	0.61	0.59	15200	0.21
5500	57.30	0.78	0.74	15300	0.21
6000	47.77	0.96	0.91	15400	0.21
6500	36.43	1.16	1.08	15500	0.21
7000	27.51	1.38	1.27	15600	0.20
7500	18.61	1.74	1.58	15700	0.20
8000	9.42	3.19	2.83	15800	0.20
8400	3.94	8.87	7.63	15900	0.20
9000	2.02	21.91	17.41	16000	0.20
9400	1.81	17.39	16.57	16100	0.20
10000	1.58	19.05	17.95	16200	0.20
10500	1.44	21.88	19.50	16300	0.20
11000	1.35	24.28	20.97	16400	0.20
11500	1.29	24.97	22.19	16500	0.20
12000	1.26	23.11	22.10	16600	0.20
12500	1.25	20.25	20.58	16700	0.20
13000	1.26	17.67	18.67	16800	0.20
13500	1.28	15.77	17.09	16900	0.20
14000	1.29	14.71	16.05	17000	0.20
14500	1.30	14.39	15.59	17100	0.20
15000	1.29	14.75	15.53	17200	0.20
15500	1.27	15.79	15.93	17300	0.20
16000	1.25	17.45	16.62	17500	0.20
16500	1.23	19.63	17.49	17600	0.20
17000	1.22	21.82	18.43	17700	0.20
17500	1.22	23.25	19.39	17800	0.20
18000	1.23	23.21	20.23	18000	0.20

Typical Performance Curves

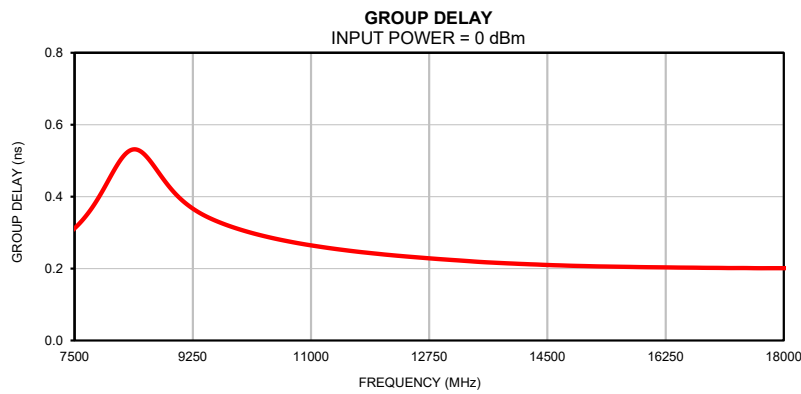
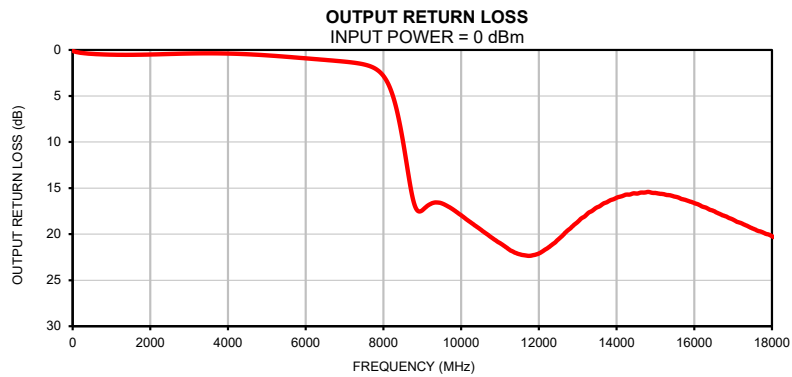
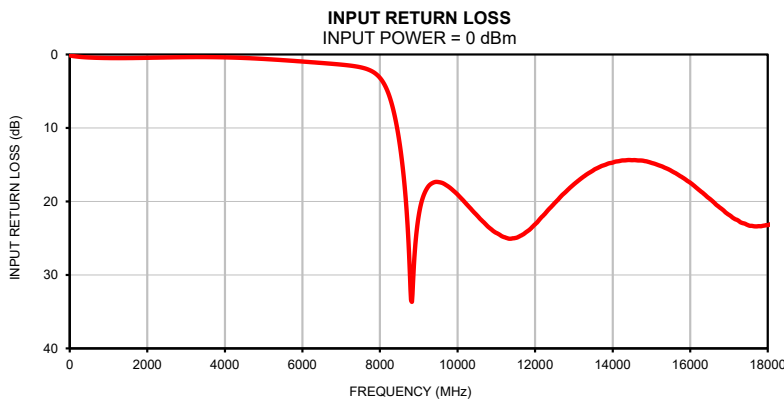
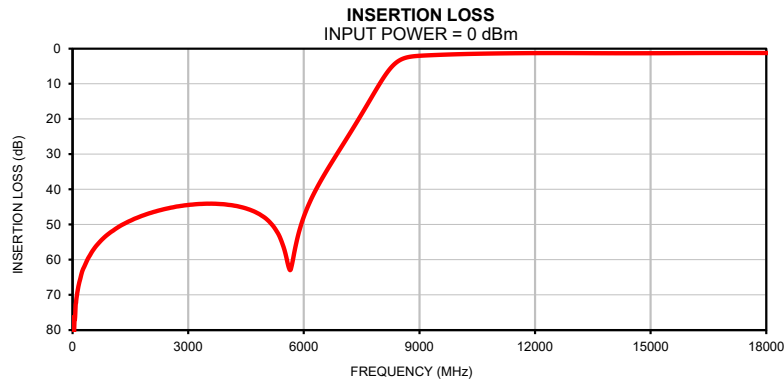

## Outline Dimensions

UK3042

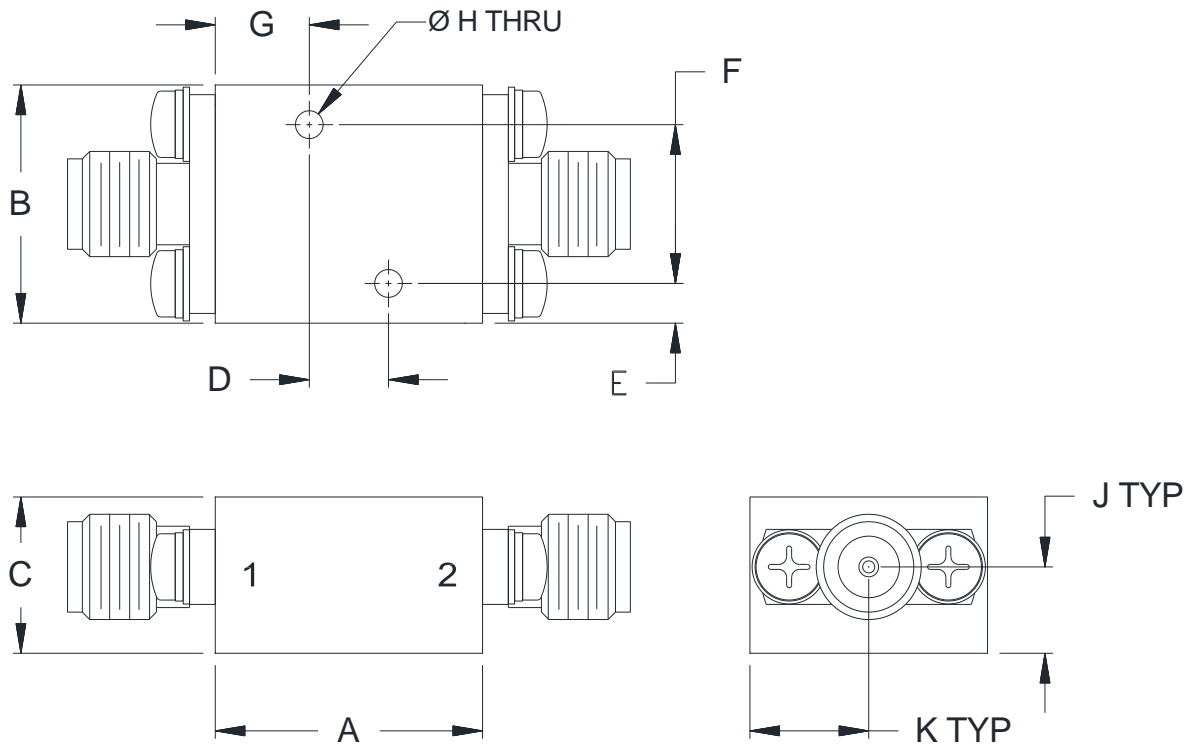

CASE#	A	B	C	D	E	F
UK3042	.68 (17.1)	.60 (15.2)	.39 (10.0)	.200 (5.08)	.10 (2.5)	.400 (10.16)

CASE#	G	H	J	K	WT.GRAMS
UK3042	.24 (6.0)	.070 (1.78)	.22 (5.5)	.30 (7.6)	24

Dimensions are in inches (mm). Tolerances: 2 Pl.  $\pm .050$ ; 3 Pl.  $\pm .015$

### Notes:

1. Case material: Brass alloy.
2. Case Finish:
  - a. Case & Cover of the units –Gold plating.
3. Refer to the individual model data sheet for the type of connectors available.



P.O. Box 350166, Brooklyn, New York 11235-0003 (718) 934-4500 Fax (718) 332-4661 For detailed performance specs & shopping online see Mini-Circuits web site



The Design Engineers Search Engine Provides ACTUAL Data Instantly From MINI-CIRCUITS At: [www.minicircuits.com](http://www.minicircuits.com)

RF/IF MICROWAVE COMPONENTS



All Mini-Circuits products are manufactured under exacting quality assurance and control standards, and are capable of meeting published specifications after being subjected to any or all of the following physical and environmental test.

Specification	Test/Inspection Condition	Reference/Spec
Operating Temperature	-55° to 125° C Ambient Environment	Individual Model Data Sheet
Storage Temperature	-55° to 125° C Ambient Environment	Individual Model Data Sheet