



(LTCC) COAXIAL

High Pass Filter

ZHFW-K133+

50Ω 14.2 to 20.5 GHz 2.92mm Female

KEY FEATURES

- Low Insertion Loss, 1.7 dB Typ.
- Return Loss, 10 dB Typ.
- Stop Band Rejection, 35 dB Typ.
- Broadband Connectorized Package.
- Power Handling: 2.5 Watts

APPLICATIONS

- Test and Measurement Equipment
- Radar, EW, and ECM Defense Systems
- Back Haul Radio Systems



Generic photo used for illustration purposes only

PRODUCT OVERVIEW

ZHFW-K133+ is a 50ohm high pass filter built in broad band connectorized package. Covering 14.2-20.5 GHz bandwidth, these units offer good matching within the passband and good rejection in stopband. ZHFW-K133+ offer low insertion loss, and excellent power handling capability. It handles up to 2.5 W RF input power and provides a wide operating temperature range from -55°C to 125°C.

FUNCTIONAL DIAGRAM

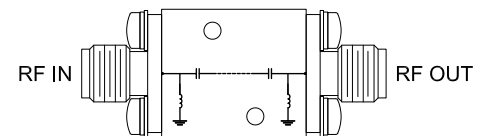

ELECTRICAL SPECIFICATIONS^{1,2} AT +25°C

Parameter		F#	Frequency (GHz)	Min.	Typ.	Max.	Units
Pass Band	Insertion Loss	F3-F4	14.2 - 16.5	—	2.5	—	dB
		F4-F5	16.5 - 19.5	—	1.7	2.4	
		F5-F6	19.5 - 20.5	—	1.7	—	
Pass Band	Return Loss	F3-F4	14.2 - 16.5	—	8	—	dB
		F4-F5	16.5 - 19.5	—	10	—	
		F5-F6	19.5 - 20.5	—	8	—	
Stop Band	Rejection	DC-F1	DC - 8.5	30	35	—	dB
		F1-F2	8.5 - 10.2	24	32	—	
	Freq. Cut-Off ³	Fc ³	13.3	—	3	—	dB

1. This filter is bi-directional, RF1 and RF2 ports may be interchanged, see S-Parameters for actual performance.

2. This component should not be used as a DC-block. In applications where DC voltage and/or current is present at either the input or output ports, external DC blocking capacitors are required.

3. Typical variation ± 5%

ABSOLUTE MAXIMUM RATINGS⁴

Parameter	Ratings
Operating Temperature	-55 °C to +125°C
Storage Temperature	-55 °C to +125°C
Input Power ⁵	2.5 W @25°C

4. Permanent damage may occur if any of these limits are exceeded.

5. Power rating applies only to signals within the passband. Power rating above +25°C operating temperature decreases linearly to 0.6W at +125°C.

TYPICAL FREQUENCY RESPONSE

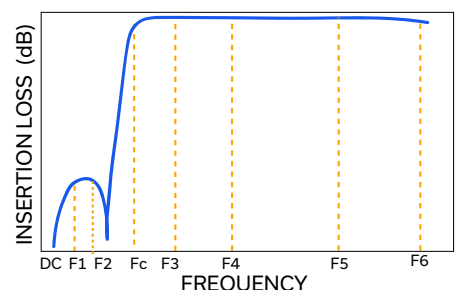



(LTCC) COAXIAL

High Pass Filter

ZHFW-K133+

Mini-Circuits

50Ω 14.2 to 20.5 GHz 2.92mm Female

TYPICAL PERFORMANCE GRAPHS

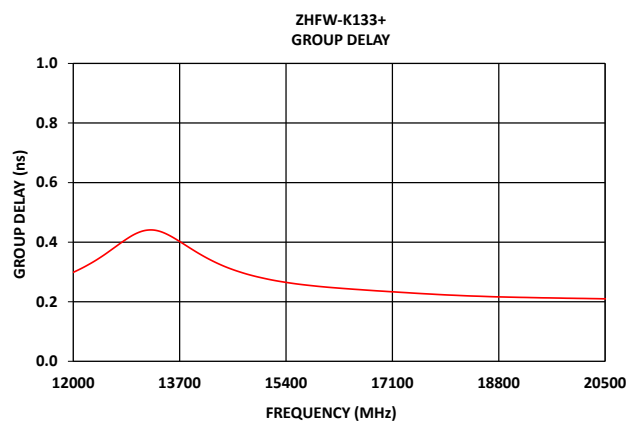
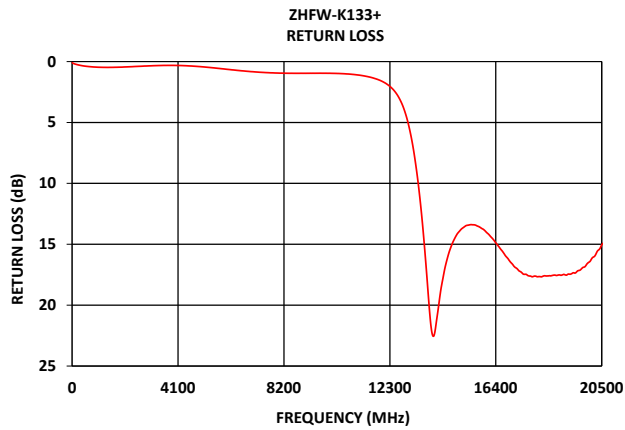
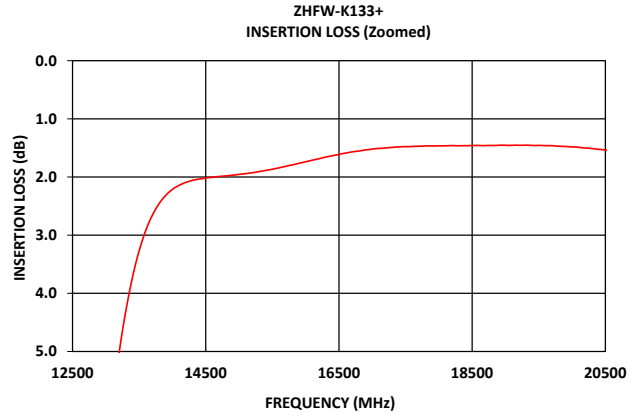
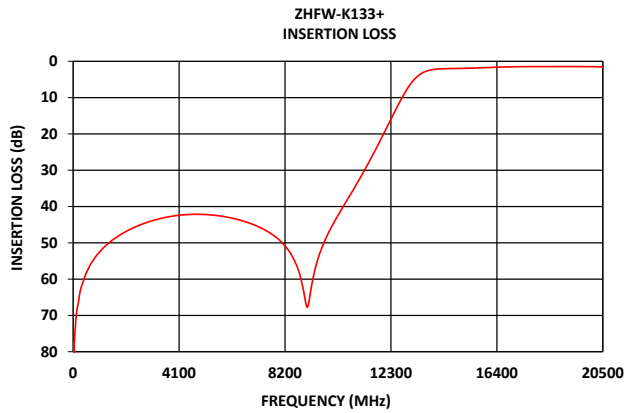



(LTCC) COAXIAL

High Pass Filter

ZHFW-K133+

50Ω 14.2 to 20.5 GHz 2.92mm Female

CONNECTOR DESCRIPTION

Function	Marking on Unit	Connector
RF1 ¹	1	2.92mm Female
RF2 ¹	2	2.92mm Female

CASE STYLE DRAWING

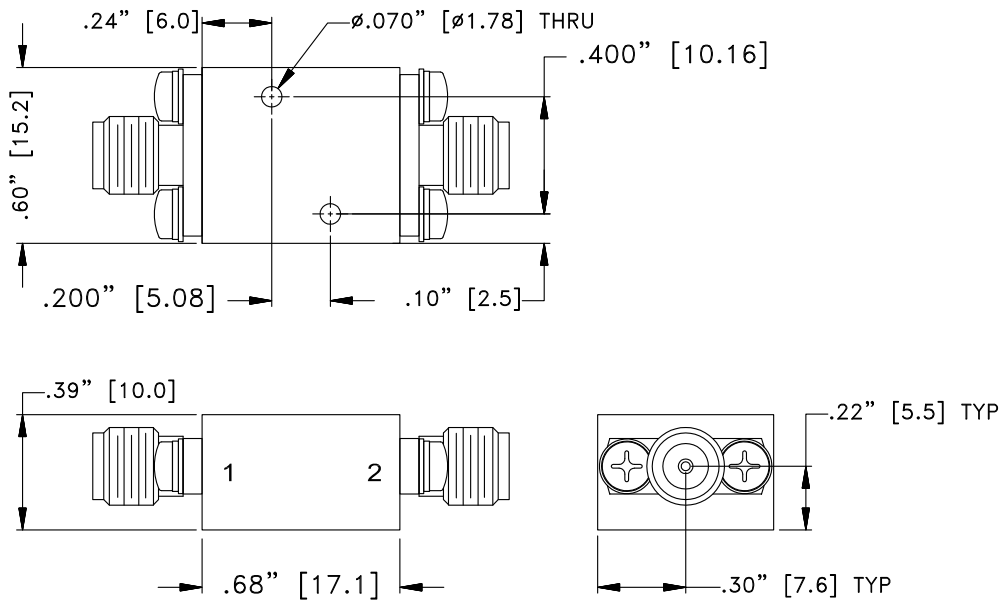

Unit weight: 24grams

Dimensions are in inches (mm). Tolerances: 2 Pl.±.050"; 3 Pl.±.015"

PRODUCT MARKING*: ZHFW-K133+

*Marking may contain other features or characters for internal lot control.



(LTCC) COAXIAL

High Pass Filter

ZHFW-K133+

50Ω 14.2 to 20.5 GHz 2.92mm Female

ADDITIONAL INFORMATION IS AVAILABLE ON OUR DASHBOARD

[CLICK HERE](#)

Performance Data & Graphs	<p>Data</p> <p>Graphs</p> <p>S-Parameter (S2P Files) Data Set (.zip file)</p>
Case Style	UK3042
RoHS Status	Compliant
Environmental Ratings	ENV124

NOTES

- A. Performance and quality attributes and conditions not expressly stated in this specification document are intended to be excluded and do not form a part of this specification document.
- B. Electrical specifications and performance data contained in this specification document are based on Mini-Circuits' applicable established test performance criteria and measurement instructions.
- C. The parts covered by this specification document are subject to Mini-Circuits' standard limited warranty and terms and conditions (collectively, "Standard Terms"); Purchasers of this part are entitled to the rights and benefits contained therein. For a full statement of the standard terms and the exclusive rights and remedies thereunder, please visit Mini-Circuits' website at www.minicircuits.com/terms/viewterm.html



Coaxial High Pass Filter

ZHFW-K133+

Typical Performance Data

FREQ.	Insertion Loss	Input Return Loss	Output Return Loss	FREQ.	Group Delay
(MHz)	(dB)	(dB)	(dB)	(MHz)	(ns)
10	77.54	0.09	0.10	14200	0.34
20	78.45	0.11	0.12	14300	0.33
40	78.09	0.14	0.15	14400	0.32
100	71.51	0.19	0.21	14500	0.31
150	68.31	0.22	0.24	14600	0.30
200	66.64	0.25	0.27	14700	0.30
300	62.56	0.30	0.33	14800	0.29
400	60.44	0.34	0.37	14900	0.29
500	58.43	0.37	0.40	15000	0.28
600	56.99	0.40	0.42	15100	0.28
700	55.63	0.42	0.44	15200	0.27
850	54.06	0.44	0.46	15300	0.27
900	53.56	0.45	0.47	15400	0.26
1000	52.72	0.46	0.48	15500	0.26
1500	49.37	0.47	0.49	15600	0.26
2000	47.08	0.44	0.45	15700	0.26
3300	43.46	0.33	0.33	15800	0.25
4400	42.23	0.34	0.33	15900	0.25
5500	42.44	0.52	0.49	16000	0.25
6100	43.14	0.66	0.62	16100	0.25
7400	46.37	0.89	0.87	16200	0.25
8000	49.36	0.94	0.94	16300	0.24
8500	53.99	0.96	0.98	16400	0.24
10200	43.07	0.97	1.02	16500	0.24
10600	38.27	1.01	1.04	16600	0.24
11000	33.47	1.08	1.08	16700	0.24
11200	30.98	1.14	1.11	16800	0.24
11300	29.71	1.18	1.13	16900	0.24
11500	27.09	1.26	1.18	17000	0.23
11700	24.38	1.38	1.26	17100	0.23
12000	20.22	1.62	1.44	17200	0.23
12100	18.79	1.74	1.53	17300	0.23
12300	15.94	2.03	1.78	17400	0.23
12500	13.12	2.47	2.17	17500	0.23
12700	10.41	3.16	2.82	17600	0.23
13000	6.84	4.99	4.63	17700	0.23
13300	4.31	8.44	8.22	17800	0.22
13500	3.27	11.97	12.21	17900	0.22
14000	2.21	22.54	30.13	18000	0.22
14200	2.09	19.86	20.26	18100	0.22
14600	2.01	15.61	14.88	18200	0.22
14800	1.98	14.56	13.82	18300	0.22
15000	1.95	13.91	13.24	18400	0.22
15200	1.93	13.54	12.97	18500	0.22
15400	1.89	13.40	12.95	18600	0.22
15600	1.84	13.42	13.13	18700	0.22
15800	1.79	13.62	13.44	18800	0.22
16000	1.74	13.93	13.91	18900	0.22
16200	1.69	14.37	14.46	19000	0.22
16400	1.63	14.88	15.10	19100	0.21
16500	1.61	15.15	15.43	19200	0.21
16800	1.55	16.01	16.37	19300	0.21
17000	1.52	16.54	16.91	19400	0.21
17500	1.48	17.47	17.56	19500	0.21
18000	1.46	17.66	17.46	19600	0.21
18500	1.46	17.59	17.33	19700	0.21
18700	1.46	17.54	17.31	19800	0.21
19000	1.45	17.50	17.30	19900	0.21
19500	1.46	17.33	17.11	20000	0.21
20500	1.54	15.05	15.08	20500	0.21

Typical Performance Curves

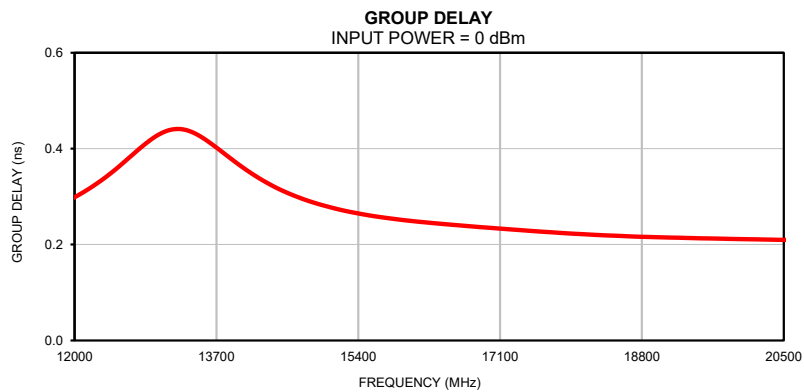
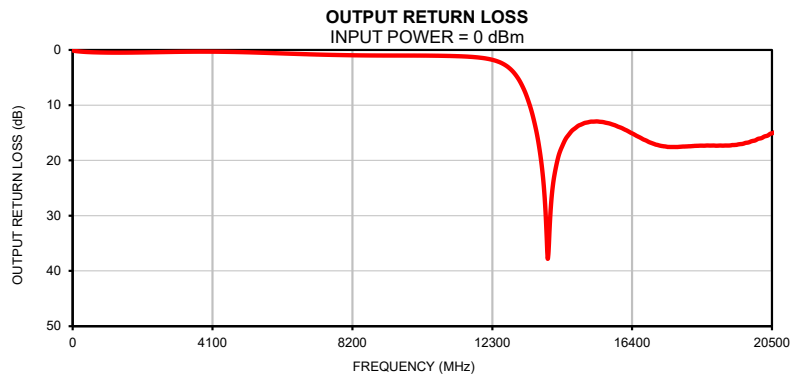
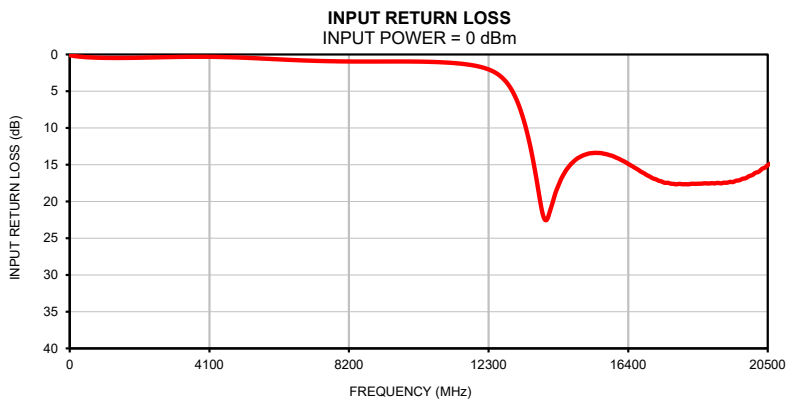
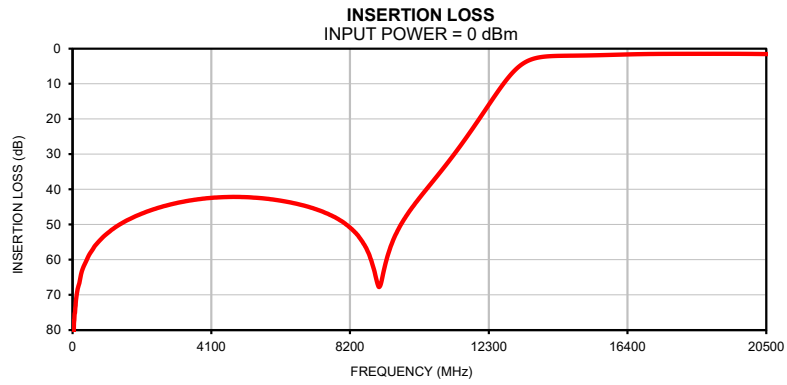

Outline Dimensions

UK3042

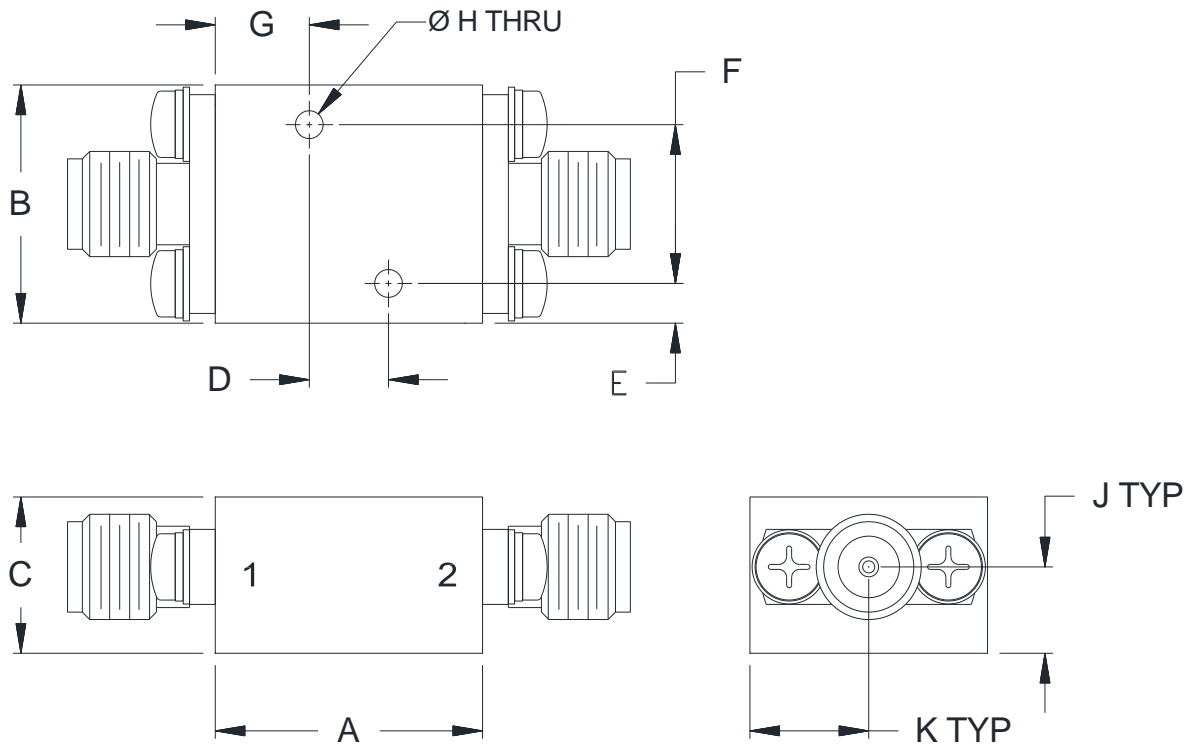

CASE#	A	B	C	D	E	F
UK3042	.68 (17.1)	.60 (15.2)	.39 (10.0)	.200 (5.08)	.10 (2.5)	.400 (10.16)

CASE#	G	H	J	K	WT.GRAMS
UK3042	.24 (6.0)	.070 (1.78)	.22 (5.5)	.30 (7.6)	24

Dimensions are in inches (mm). Tolerances: 2 Pl. $\pm .050$; 3 Pl. $\pm .015$

Notes:

1. Case material: Brass alloy.
2. Case Finish:
 - a. Case & Cover of the units –Gold plating.
3. Refer to the individual model data sheet for the type of connectors available.



P.O. Box 350166, Brooklyn, New York 11235-0003 (718) 934-4500 Fax (718) 332-4661 For detailed performance specs & shopping online see Mini-Circuits web site



The Design Engineers Search Engine Provides ACTUAL Data Instantly From MINI-CIRCUITS At: www.minicircuits.com

RF/IF MICROWAVE COMPONENTS



All Mini-Circuits products are manufactured under exacting quality assurance and control standards, and are capable of meeting published specifications after being subjected to any or all of the following physical and environmental test.

Specification	Test/Inspection Condition	Reference/Spec
Operating Temperature	-55° to 125° C Ambient Environment	Individual Model Data Sheet
Storage Temperature	-55° to 125° C Ambient Environment	Individual Model Data Sheet