



(LTCC) COAXIAL

High Pass Filter

ZHFG-K3250+

50Ω 3.65 to 16.5 GHz 2.92mm Female

KEY FEATURES

- Low Insertion Loss, 1.8 dB Typ.
- Return Loss, 12 dB Typ.
- Stop Band Rejection, 46 dB Typ.
- Broadband Connectorized Package.
- Power Handling: 3 Watts

APPLICATIONS

- Test and Measurement Equipment.
- SATCOM.
- 5G MIMO and Back Haul Radio Systems.
- WiFi 6E.



Generic photo used for illustration purposes only

PRODUCT OVERVIEW

ZHFG-K3250+ is a 50ohm high pass filter built in broad band connectorized package. Covering 3.65-16.5 GHz bandwidth, these units offer good matching within the passband and good rejection in stopband. ZHFG-K3250+ offer low insertion loss, and excellent power handling capability. It handles up to 3 W RF input power and provides a wide operating temperature range from -55°C to 125°C.

FUNCTIONAL DIAGRAM

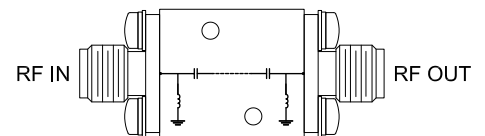

ELECTRICAL SPECIFICATIONS^{1,2} AT +25°C

Parameter		F#	Frequency (GHz)	Min.	Typ.	Max.	Units
Pass Band	Insertion Loss	F3-F4	3.65 - 4.3	—	2.0	—	dB
		F4-F5	4.3 - 5.5	—	1.3	2.0	
		F5-F6	5.5 - 14.1	—	1.1	1.8	
		F6-F7	14.1-16.5	—	2.2	—	
	Return Loss	F3-F4	3.65 - 16.5	—	11	—	dB
Stop Band	Rejection	DC-F1	DC - 2	38	46	—	dB
		F1-F2	2 - 2.5	27	39	—	dB
	Freq. Cut-Off ³	Fc ³	3.25	—	3	—	dB

1. This filter is bi-directional, RF1 and RF2 ports may be interchanged, see S-Parameters for actual performance.

2. This component should not be used as a DC-block. In applications where DC voltage and/or current is present at either the input or output ports, external DC blocking capacitors are required.

3. Typical variation ± 5%

ABSOLUTE MAXIMUM RATINGS⁴

Parameter	Ratings
Operating Temperature	-55 °C to +125 °C
Storage Temperature	-55 °C to +125 °C
Input Power ⁵	3 W @25°C

4. Permanent damage may occur if any of these limits are exceeded.

5. Power rating applies only to signals within the passband. Power rating above +25°C operating temperature decreases linearly to 0.6 W at +125°C.

TYPICAL FREQUENCY RESPONSE AT +25°C

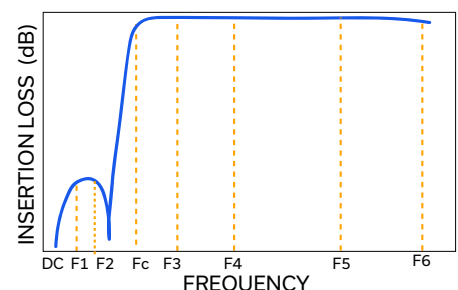



(LTCC) COAXIAL

High Pass Filter

ZHFG-K3250+

Mini-Circuits

50Ω 3.65 to 16.5 GHz 2.92mm Female

TYPICAL PERFORMANCE GRAPHS

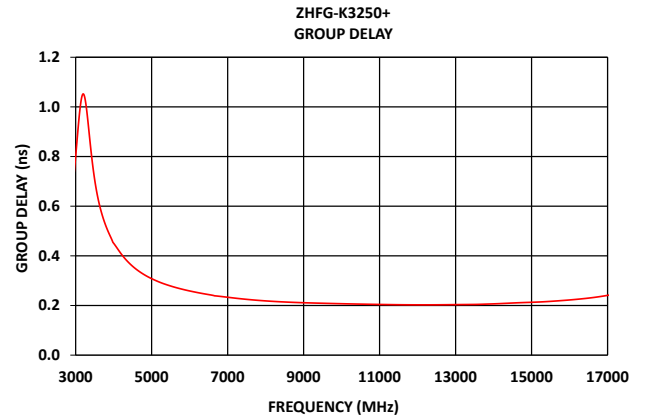
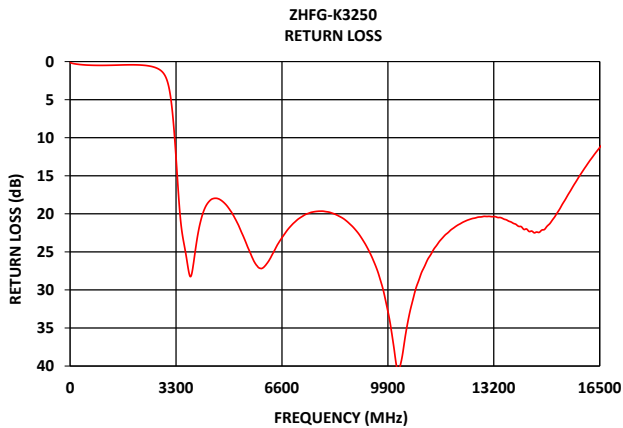
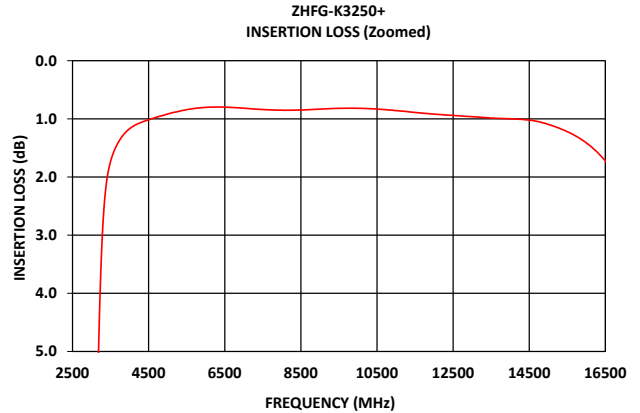
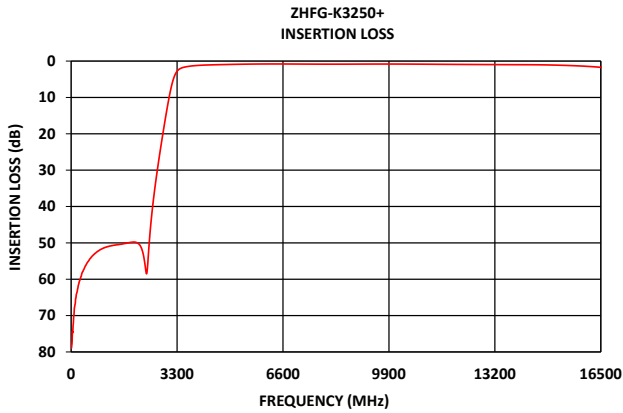



(LTCC) COAXIAL

High Pass Filter

ZHFG-K3250+

50Ω 3.65 to 16.5 GHz 2.92mm Female

CONNECTOR DESCRIPTION

Function	Marking on Unit	Connector
RF1 ¹	1	2.92mm Female
RF2 ¹	2	2.92mm Female

CASE STYLE DRAWING

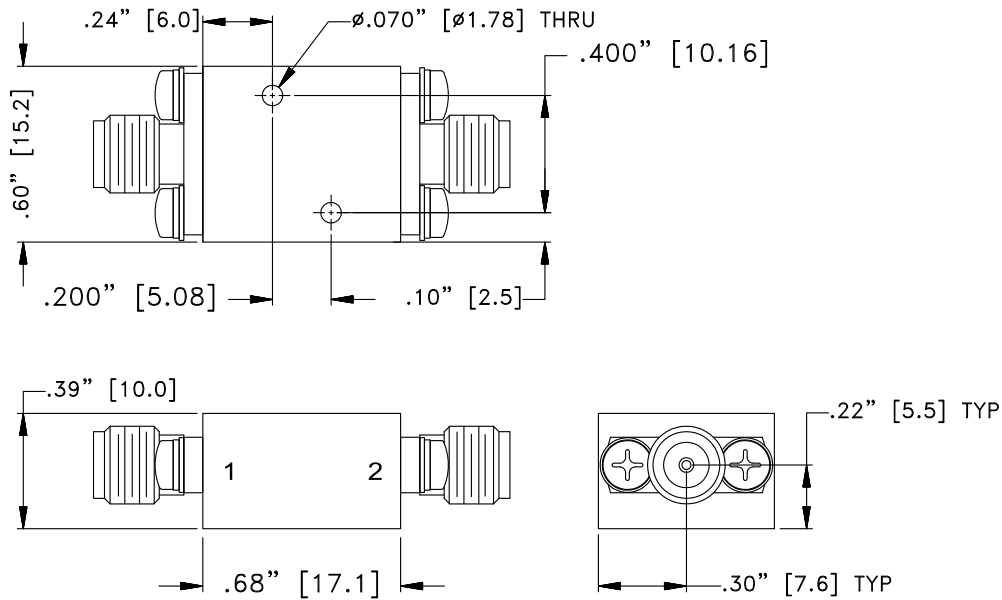

Unit weight: 24grams

Dimensions are in inches (mm). Tolerances: 2 Pl.±.050"; 3 Pl.±.015"

PRODUCT MARKING*: ZHFG-K3250+

*Marking may contain other features or characters for internal lot control.



(LTCC) COAXIAL

High Pass Filter

ZHFG-K3250+

50Ω 3.65 to 16.5 GHz 2.92mm Female

ADDITIONAL INFORMATION IS AVAILABLE ON OUR DASHBOARD

[CLICK HERE](#)

Performance Data & Graphs	Data Graphs S-Parameter (S2P Files) Data Set (.zip file)
Case Style	UK3042
RoHS Status	Compliant
Environmental Ratings	ENV124

NOTES

- A. Performance and quality attributes and conditions not expressly stated in this specification document are intended to be excluded and do not form a part of this specification document.
- B. Electrical specifications and performance data contained in this specification document are based on Mini-Circuits' applicable established test performance criteria and measurement instructions.
- C. The parts covered by this specification document are subject to Mini-Circuits' standard limited warranty and terms and conditions (collectively, "Standard Terms"); Purchasers of this part are entitled to the rights and benefits contained therein. For a full statement of the standard terms and the exclusive rights and remedies thereunder, please visit Mini-Circuits' website at www.minicircuits.com/terms/viewterm.html



Coaxial High Pass Filter

ZHFG-K3250+

Typical Performance Data

FREQ.	Insertion Loss	Input Return Loss	Output Return Loss	FREQ.	Group Delay
(MHz)	(dB)	(dB)	(dB)	(MHz)	(ns)
10	78.96	0.13	0.14	3650	0.59
20	78.15	0.16	0.17	3750	0.54
40	74.38	0.19	0.20	4000	0.45
100	67.99	0.26	0.26	4100	0.43
120	66.98	0.27	0.28	4200	0.41
200	62.71	0.33	0.33	4300	0.39
300	59.40	0.38	0.38	4400	0.37
400	57.25	0.42	0.42	4500	0.36
500	55.49	0.45	0.44	4600	0.35
600	54.27	0.47	0.46	4700	0.33
700	53.27	0.48	0.47	4800	0.32
800	52.50	0.49	0.48	4900	0.32
900	51.91	0.50	0.48	5000	0.31
1000	51.47	0.50	0.48	5100	0.30
1500	50.44	0.46	0.45	5500	0.28
2000	49.81	0.43	0.42	5600	0.27
2500	43.21	0.61	0.62	6000	0.26
3000	12.48	2.23	2.46	6500	0.24
3250	3.51	9.61	11.17	6700	0.24
3650	1.47	26.42	19.39	6800	0.24
4100	1.12	20.45	19.76	7000	0.23
4300	1.06	18.53	18.83	7200	0.23
5200	0.88	21.11	22.97	7400	0.23
5500	0.84	24.01	26.60	7600	0.22
6000	0.80	27.13	25.77	7800	0.22
7000	0.82	21.09	19.09	8000	0.22
8500	0.85	20.59	20.24	8200	0.22
9000	0.83	22.68	23.05	8400	0.21
10000	0.82	35.10	32.76	8600	0.21
10200	0.82	40.58	32.11	8800	0.21
10400	0.83	37.28	30.14	9000	0.21
10600	0.84	32.62	28.18	10000	0.21
10800	0.85	29.45	26.60	10050	0.21
11000	0.86	27.27	25.36	10800	0.20
11200	0.87	25.60	24.38	11000	0.20
11400	0.88	24.26	23.58	11500	0.20
11600	0.90	23.18	22.97	11650	0.20
11800	0.91	22.37	22.50	12000	0.20
12000	0.92	21.70	22.13	12050	0.20
12200	0.93	21.19	21.82	12100	0.20
12400	0.94	20.80	21.53	12600	0.20
12600	0.95	20.57	21.37	12800	0.20
12800	0.95	20.41	21.22	12900	0.20
13000	0.96	20.35	21.15	13000	0.20
13200	0.97	20.37	21.15	13200	0.20
13620	0.99	20.85	21.20	13500	0.20
13650	0.99	20.93	21.21	13620	0.20
13800	1.00	21.23	21.32	13650	0.20
14010	1.00	21.66	21.49	13800	0.21
15000	1.09	20.97	21.26	14010	0.21
15600	1.25	16.90	18.22	15000	0.21
15810	1.33	15.44	16.82	15600	0.22
15900	1.37	14.84	16.23	15810	0.22
16020	1.42	14.07	15.42	15900	0.22
16290	1.57	12.46	13.68	16020	0.22
16350	1.62	12.11	13.29	16290	0.23
16410	1.66	11.78	12.93	16350	0.23
16440	1.68	11.62	12.75	16410	0.23
16470	1.70	11.46	12.56	16440	0.23
16500	1.72	11.29	12.37	16500	0.23

Typical Performance Curves

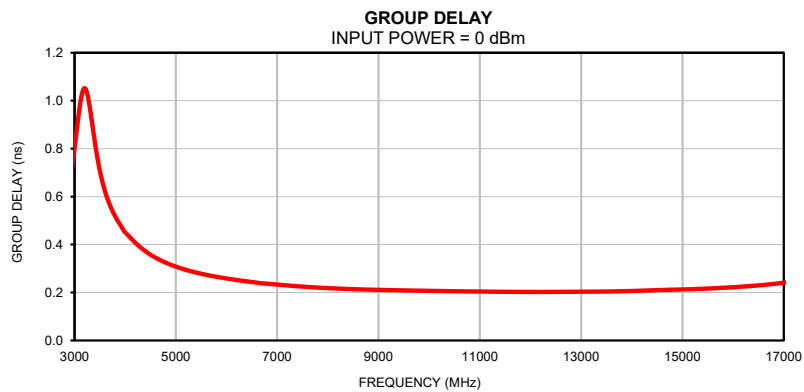
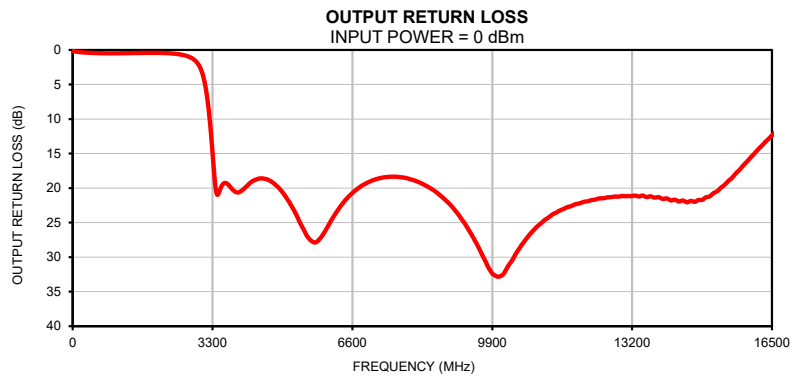
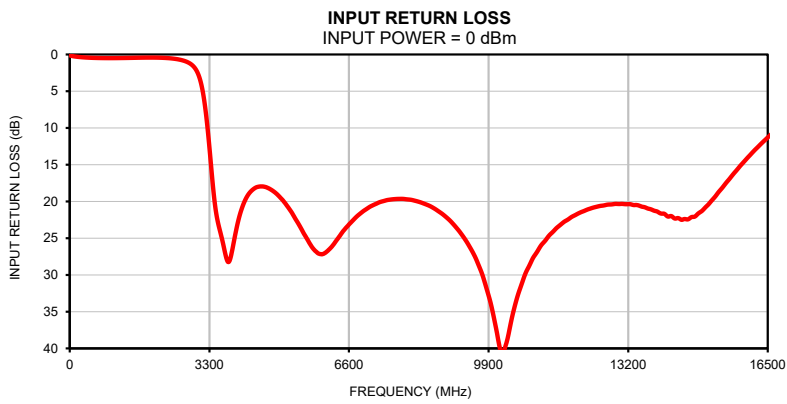
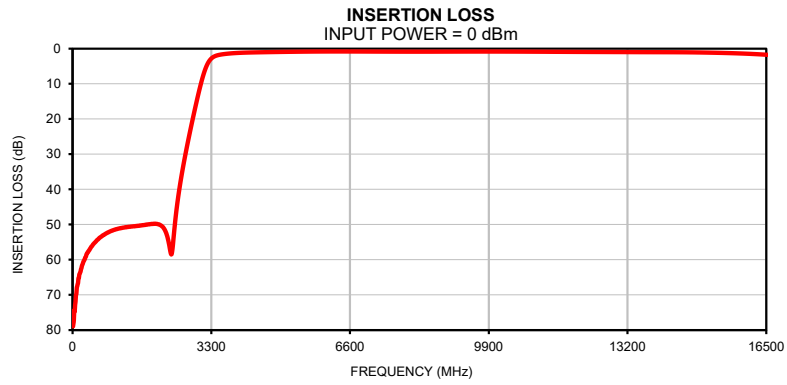

Outline Dimensions

UK3042

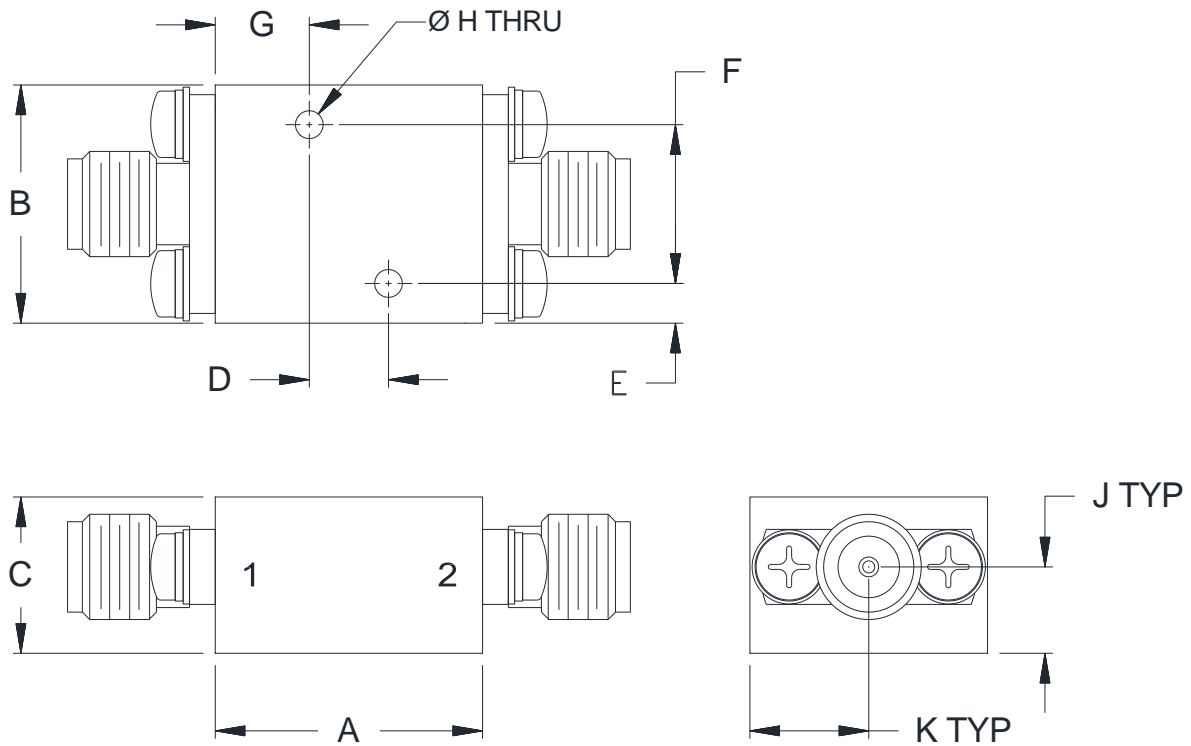

CASE#	A	B	C	D	E	F
UK3042	.68 (17.1)	.60 (15.2)	.39 (10.0)	.200 (5.08)	.10 (2.5)	.400 (10.16)

CASE#	G	H	J	K	WT.GRAMS
UK3042	.24 (6.0)	.070 (1.78)	.22 (5.5)	.30 (7.6)	24

Dimensions are in inches (mm). Tolerances: 2 Pl. $\pm .050$; 3 Pl. $\pm .015$

Notes:

1. Case material: Brass alloy.
2. Case Finish:
 - a. Case & Cover of the units –Gold plating.
3. Refer to the individual model data sheet for the type of connectors available.



P.O. Box 350166, Brooklyn, New York 11235-0003 (718) 934-4500 Fax (718) 332-4661 For detailed performance specs & shopping online see Mini-Circuits web site



The Design Engineers Search Engine Provides ACTUAL Data Instantly From MINI-CIRCUITS At: www.minicircuits.com

RF/IF MICROWAVE COMPONENTS



All Mini-Circuits products are manufactured under exacting quality assurance and control standards, and are capable of meeting published specifications after being subjected to any or all of the following physical and environmental test.

Specification	Test/Inspection Condition	Reference/Spec
Operating Temperature	-55° to 125° C Ambient Environment	Individual Model Data Sheet
Storage Temperature	-55° to 125° C Ambient Environment	Individual Model Data Sheet