

Power Splitter/Combiner

ZFSC-4375+

4 Way-0° 75Ω 50 to 90 MHz



BNC version shown
CASE STYLE: G15

Connectors Model
BNC ZFSC-4375+
BRACKET (OPTION "B")

Maximum Ratings

Operating Temperature	-55°C to 100°C
Storage Temperature	-55°C to 100°C
Power Input (as a splitter)	1W max.
Internal Dissipation	0.250W max.

Permanent damage may occur if any of these limits are exceeded.

Coaxial Connections

SUM PORT	S
PORT 1	1
PORT 2	2
PORT 3	3
PORT 4	4

Features

- high isolation, 34 dB typ.
- low insertion loss, 0.3 dB typ.
- rugged shielded case
- excellent VSWR, 1.05:1 typ.

Applications

- VHF
- radio communication

+RoHS Compliant
The +Suffix identifies RoHS Compliance. See our web site for RoHS Compliance methodologies and qualifications

Electrical Specifications

FREQ. RANGE (MHz)	ISOLATION (dB)		INSERTION LOSS (dB) ABOVE 6.0 dB		PHASE UNBALANCE (Degrees)	AMPLITUDE UNBALANCE (dB)
	Typ.	Min.	Typ.	Max.		
f_L - f_U					Max.	Max.
50-90	34	30	0.3	0.8	4	0.15

Outline Drawing

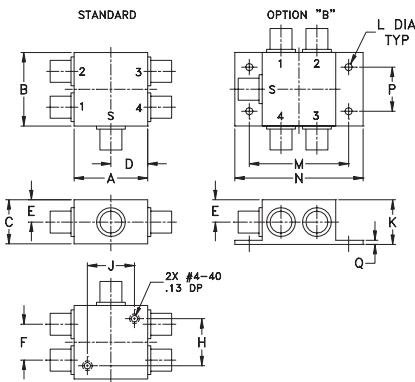

Outline Dimensions (inch/mm)

A	B	C	D	E	F	G	H
1.25	1.25	.75	.63	.38	.61	--	.80
31.75	31.75	19.05	16.00	9.65	15.49	--	20.32
J	K	L	M	N	P	Q	wt
.80	.76	.125	1.688	2.18	.75	.07	grams
20.32	19.30	3.18	42.88	55.37	19.05	1.78	85.0

Typical Performance Data

Freq. (MHz)	Total Loss ¹ (dB)				Amp. Unbal. (dB)	Isolation (dB)			Phase Unbal. (deg.)	VSWR S	VSWR 1	VSWR 2	VSWR 3	VSWR 4
	S-1	S-2	S-3	S-4		1-2	1-4	3-4						
50.00	6.29	6.29	6.30	6.29	0.01	45.87	37.46	46.83	0.25	1.08	1.01	1.01	1.01	1.01
52.00	6.29	6.29	6.30	6.30	0.01	45.35	37.43	46.49	0.22	1.08	1.02	1.01	1.01	1.01
55.00	6.29	6.29	6.30	6.29	0.01	45.15	37.39	46.06	0.28	1.07	1.02	1.01	1.02	1.02
58.00	6.31	6.30	6.31	6.31	0.01	44.78	37.24	45.54	0.28	1.07	1.02	1.02	1.02	1.02
60.00	6.30	6.30	6.30	6.30	0.01	44.24	37.29	45.24	0.40	1.06	1.02	1.02	1.02	1.02
62.00	6.31	6.31	6.31	6.31	0.01	43.95	37.16	44.90	0.28	1.06	1.02	1.02	1.02	1.02
65.00	6.30	6.31	6.30	6.31	0.01	43.62	37.08	44.62	0.37	1.06	1.02	1.02	1.02	1.02
70.00	6.31	6.32	6.32	6.32	0.01	43.13	36.98	43.83	0.33	1.05	1.02	1.02	1.02	1.02
72.00	6.30	6.31	6.33	6.32	0.02	42.80	36.99	43.62	0.37	1.04	1.02	1.02	1.02	1.02
75.00	6.31	6.31	6.31	6.31	0.01	42.50	36.91	43.36	0.39	1.04	1.02	1.02	1.02	1.02
77.00	6.32	6.32	6.33	6.32	0.01	42.38	36.84	43.13	0.41	1.04	1.02	1.02	1.02	1.02
80.00	6.31	6.32	6.31	6.31	0.01	41.89	36.81	42.65	0.36	1.03	1.02	1.02	1.02	1.02
83.00	6.32	6.32	6.32	6.33	0.02	41.68	36.76	42.52	0.38	1.03	1.02	1.02	1.02	1.02
85.00	6.31	6.32	6.32	6.32	0.01	41.46	36.66	42.21	0.38	1.03	1.02	1.02	1.02	1.02
90.00	6.33	6.32	6.32	6.32	0.01	40.89	36.58	41.70	0.54	1.03	1.02	1.02	1.02	1.02

1. Total Loss = Insertion Loss + 6dB splitter loss.

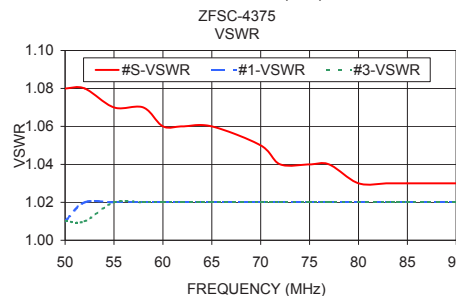
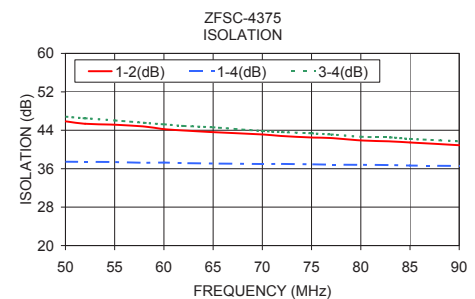
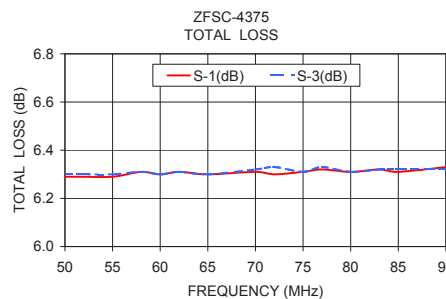

electrical schematic



Notes

- Performance and quality attributes and conditions not expressly stated in this specification document are intended to be excluded and do not form a part of this specification document.
- Electrical specifications and performance data contained in this specification document are based on Mini-Circuit's applicable established test performance criteria and measurement instructions.
- The parts covered by this specification document are subject to Mini-Circuits standard limited warranty and terms and conditions (collectively, "Standard Terms"); Purchasers of this part are entitled to the rights and benefits contained therein. For a full statement of the Standard Terms and the exclusive rights and remedies thereunder, please visit Mini-Circuits' website at www.minicircuits.com/WCLStore/terms.jsp



4 Way-0° Power Splitter/Combiner

ZFSC-4375+

Typical Performance Data

FREQ. (MHz)	TOTAL LOSS ¹ (dB)				AMP. UNBAL. (dB)	ISOLATION (dB)			PHASE UNBAL. (deg.)	FREQ. (MHz)	VSWR (:1)				
	S-1	S-2	S-3	S-4		1-2	1-4	3-4			S	1	2	3	4
50.0	6.29	6.29	6.30	6.29	0.01	45.87	37.46	46.83	0.25	50.0	1.08	1.01	1.01	1.01	1.01
51.0	6.29	6.29	6.30	6.31	0.01	45.63	37.48	46.70	0.21	51.0	1.08	1.01	1.01	1.01	1.01
52.0	6.29	6.29	6.30	6.30	0.01	45.35	37.43	46.49	0.22	52.0	1.08	1.02	1.01	1.01	1.01
53.0	6.30	6.29	6.29	6.30	0.01	45.39	37.45	46.41	0.25	53.0	1.07	1.02	1.01	1.01	1.02
54.0	6.29	6.30	6.31	6.30	0.01	45.12	37.38	46.14	0.25	54.0	1.07	1.02	1.01	1.01	1.02
55.0	6.29	6.29	6.30	6.29	0.01	45.15	37.39	46.06	0.28	55.0	1.07	1.02	1.01	1.02	1.02
56.0	6.30	6.30	6.31	6.30	0.01	44.90	37.30	45.90	0.27	56.0	1.07	1.02	1.01	1.02	1.02
57.0	6.31	6.30	6.31	6.31	0.01	44.76	37.24	45.65	0.26	57.0	1.07	1.02	1.02	1.02	1.02
58.0	6.31	6.30	6.31	6.31	0.01	44.78	37.24	45.54	0.28	58.0	1.07	1.02	1.02	1.02	1.02
59.0	6.30	6.31	6.31	6.30	0.01	44.44	37.27	45.42	0.31	59.0	1.06	1.02	1.02	1.02	1.02
60.0	6.30	6.30	6.30	6.30	0.01	44.24	37.29	45.24	0.40	60.0	1.06	1.02	1.02	1.02	1.02
61.0	6.30	6.31	6.30	6.30	0.01	44.23	37.21	45.06	0.19	61.0	1.06	1.02	1.02	1.02	1.02
62.0	6.31	6.31	6.31	6.31	0.01	43.95	37.16	44.90	0.28	62.0	1.06	1.02	1.02	1.02	1.02
63.0	6.31	6.32	6.31	6.31	0.01	43.86	37.07	44.82	0.27	63.0	1.06	1.02	1.02	1.02	1.02
64.0	6.31	6.31	6.31	6.31	0.00	43.81	37.13	44.70	0.27	64.0	1.06	1.02	1.02	1.02	1.02
65.0	6.30	6.31	6.30	6.31	0.01	43.62	37.08	44.62	0.37	65.0	1.06	1.02	1.02	1.02	1.02
66.0	6.31	6.31	6.31	6.29	0.02	43.64	37.08	44.32	0.25	66.0	1.05	1.02	1.02	1.02	1.02
67.0	6.31	6.32	6.31	6.32	0.01	43.36	37.09	44.20	0.36	67.0	1.05	1.02	1.02	1.02	1.02
68.0	6.31	6.31	6.32	6.31	0.01	43.25	37.02	44.08	0.31	68.0	1.05	1.02	1.02	1.02	1.02
69.0	6.31	6.32	6.32	6.32	0.01	43.18	37.00	44.09	0.31	69.0	1.05	1.02	1.02	1.02	1.02
70.0	6.31	6.32	6.32	6.32	0.01	43.13	36.98	43.83	0.33	70.0	1.05	1.02	1.02	1.02	1.02
71.0	6.32	6.31	6.31	6.33	0.02	42.88	36.94	43.86	0.34	71.0	1.05	1.02	1.02	1.02	1.02
72.0	6.30	6.31	6.33	6.32	0.02	42.80	36.99	43.62	0.37	72.0	1.04	1.02	1.02	1.02	1.02
73.0	6.32	6.32	6.31	6.33	0.02	42.78	36.91	43.42	0.35	73.0	1.04	1.02	1.02	1.02	1.02
74.0	6.32	6.32	6.31	6.31	0.01	42.59	36.94	43.42	0.34	74.0	1.04	1.02	1.02	1.02	1.02
75.0	6.31	6.31	6.31	6.31	0.01	42.50	36.91	43.36	0.39	75.0	1.04	1.02	1.02	1.02	1.02
76.0	6.31	6.31	6.32	6.33	0.02	42.24	36.84	43.24	0.40	76.0	1.04	1.02	1.02	1.02	1.02
77.0	6.32	6.32	6.33	6.32	0.01	42.38	36.84	43.13	0.41	77.0	1.04	1.02	1.02	1.02	1.02
78.0	6.32	6.31	6.33	6.32	0.01	42.18	36.85	42.89	0.35	78.0	1.04	1.02	1.02	1.02	1.02
79.0	6.31	6.32	6.33	6.33	0.02	42.03	36.82	42.84	0.36	79.0	1.04	1.02	1.02	1.02	1.02
80.0	6.31	6.32	6.31	6.31	0.01	41.89	36.81	42.65	0.36	80.0	1.03	1.02	1.02	1.02	1.02
81.0	6.33	6.32	6.33	6.32	0.01	41.74	36.81	42.57	0.40	81.0	1.03	1.02	1.02	1.02	1.02
82.0	6.32	6.32	6.32	6.32	0.00	41.80	36.72	42.47	0.34	82.0	1.03	1.02	1.02	1.02	1.02
83.0	6.32	6.32	6.32	6.33	0.02	41.68	36.76	42.52	0.38	83.0	1.03	1.02	1.02	1.02	1.02
84.0	6.32	6.32	6.32	6.32	0.00	41.43	36.68	42.33	0.35	84.0	1.03	1.02	1.02	1.02	1.02
85.0	6.31	6.32	6.32	6.32	0.01	41.46	36.66	42.21	0.38	85.0	1.03	1.02	1.02	1.02	1.02
86.0	6.32	6.32	6.33	6.33	0.01	41.33	36.74	42.07	0.47	86.0	1.03	1.02	1.02	1.02	1.02
87.0	6.31	6.32	6.32	6.32	0.00	41.24	36.70	41.94	0.47	87.0	1.03	1.02	1.02	1.02	1.02
88.0	6.32	6.32	6.33	6.33	0.02	41.17	36.60	41.99	0.41	88.0	1.03	1.02	1.02	1.02	1.02
89.0	6.31	6.32	6.32	6.32	0.01	41.06	36.61	41.71	0.43	89.0	1.03	1.02	1.02	1.02	1.02
90.0	6.33	6.32	6.32	6.32	0.01	40.89	36.58	41.70	0.54	90.0	1.03	1.02	1.02	1.02	1.02

¹ Total Loss = Insertion Loss+ 6dB Splitter Loss



4 Way-0° Power Splitter/Combiner

ZFSC-4375+

Typical Performance Curves

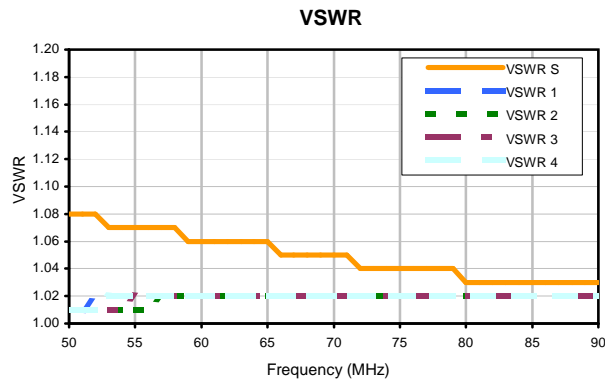
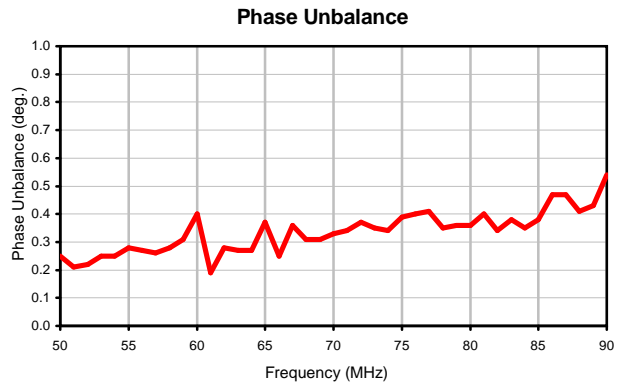
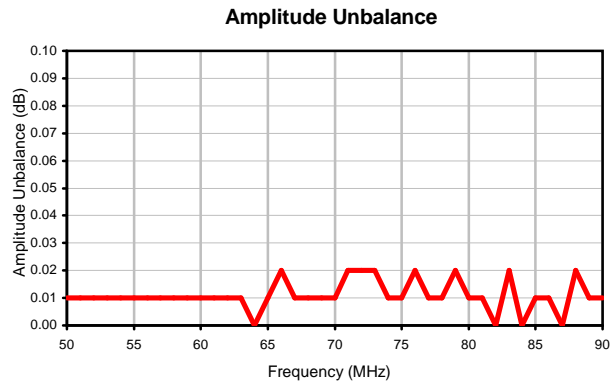
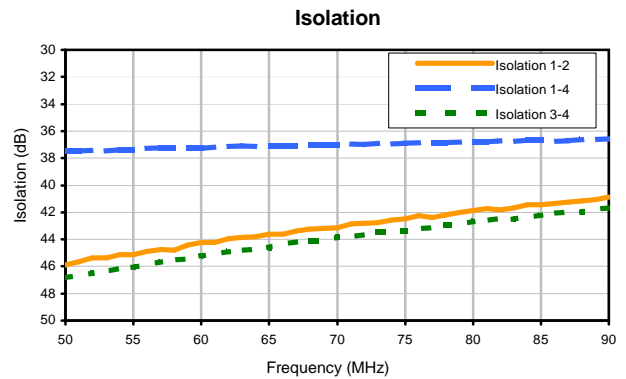
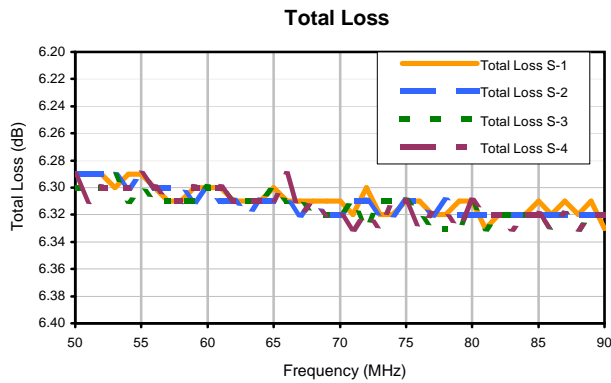

REV. X2
ZFSC-4375+
120424
Page 1 of 1

Outline Dimensions

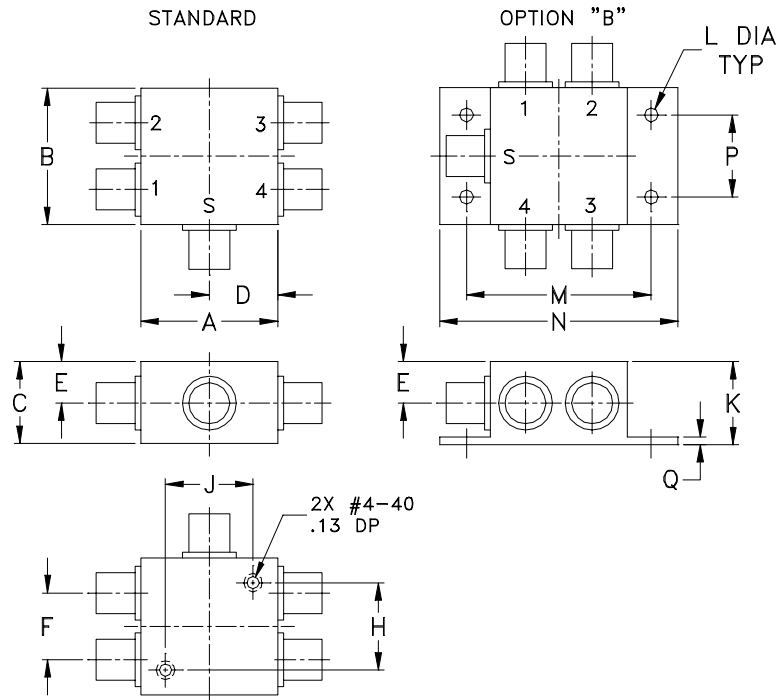

CASE #	A	B	C	D	E	F	G	H	J	K	L
G15	1.25 (31.75)	1.25 (31.75)	.75 (19.05)	.63 (16.00)	.38 (9.65)	.61 (15.49)	--	.80 (20.32)	.80 (20.32)	.76 (19.30)	.125 (3.18)

CASE #	M	N	P	Q	WT. GRAM
G15	1.688 (42.88)	2.18 (55.37)	.75 (19.05)	.07 (1.78)	85.0

Dimensions are in inches (mm). Tolerances: 2Pl. $\pm .03$; 3 Pl. $\pm .015$

Notes:

- Case material: Aluminum alloy.
- Case finish:
For RoHS Case Styles: Clear chemical conversion coating, non-chrome or trivalent chrome based.
- Mounting bracket available on request. Add suffix B to part number.
- For Bracket version, option "B" dimension "K" changes from .76 to .90 inches when connectors are type TNC.



All Mini-Circuits products are manufactured under exacting quality assurance and control standards, and are capable of meeting published specifications after being subjected to any or all of the following physical and environmental test.

Specification	Test/Inspection Condition	Reference/Spec
Operating Temperature	-55° to 100°C Ambient Environment	Individual Model Data Sheet
Storage Temperature	-55° to 100° C Ambient Environment	Individual Model Data Sheet
Barometric Pressure	100,000 Feet	MIL-STD-202, Method 105, Condition D
Humidity	90% RH, 65°C Units may require bake-out after humidity to restore full performance.	MIL-STD-202, Method 103
Thermal Shock	-65° to 125°C, 5 cycles	MIL-STD-202, Method 107, Condition B
Vibration (High Frequency)	20g peak, 10-2000 Hz, 12 times in each of three perpendicular directions (total 36)	MIL-STD-202, Method 204, Condition D
Mechanical Shock	100g, 6ms sawtooth, 3 shocks each direction 3 axes (total 18)	MIL-STD-202, Method 213, Condition I