

Coaxial Amplifier

ZFL-2000+

50Ω Medium Power 10 to 2000 MHz

Features

- wideband, 10 to 2000 MHz
- high gain, 20 dB min.
- unconditionally stable
- protected by US Patent, 6,943,629

Applications

- instrumentation
- communication
- lab use



ZFL-2000X+

ZFL-2000+

Generic photo used for illustration purposes only

CASE STYLE: SS98

Connectors	Model
SMA	ZFL-2000+
BRACKET (OPTION "B")	
SMA	ZFL-2000X+

+RoHS Compliant

The +Suffix identifies RoHS Compliance. See our web site for RoHS Compliance methodologies and qualifications

Amplifier Electrical Specifications

MODEL NO.	FREQUENCY (MHz)		GAIN (dB)		MAXIMUM POWER (dBm)		DYNAMIC RANGE		VSWR (:1) Typ.		DC POWER	
	f_L	f_U	Min.	Flatness Max.	Output ¹ (1 dB Compr.)	Input (no damage)	NF (dB) Typ.	IP3 (dBm) Typ.	In	Out	Volt (V) Nom.	Current (mA) Max.
ZFL-2000+	10	2000	20	±1.5	+16	+5	7.0	+25	2.0	2.0	15	120
ZFL-2000X+	10	2000	20	±1.5	+16	+5	7.0	+25	2.0	2.0	15	120

* Heat sink not included

¹+15 dBm below 1000 MHz.

Open load is not recommended, potentially can cause damage. With no load derate max input power by 20 dB

To order without heat sink, add suffix X to model number. Alternative heat sinking and heat removal must be provided by the user to limit maximum temperature to 71°C, in order to ensure proper performance. For reference, this requires thermal resistance of user's external heat sink to be 15°C/W Max.

Maximum Ratings

Operating Temperature -20°C to 71°C

Storage Temperature -55°C to 100°C

DC Voltage +17V Max.

Permanent damage may occur if any of these limits are exceeded.

Outline Drawing

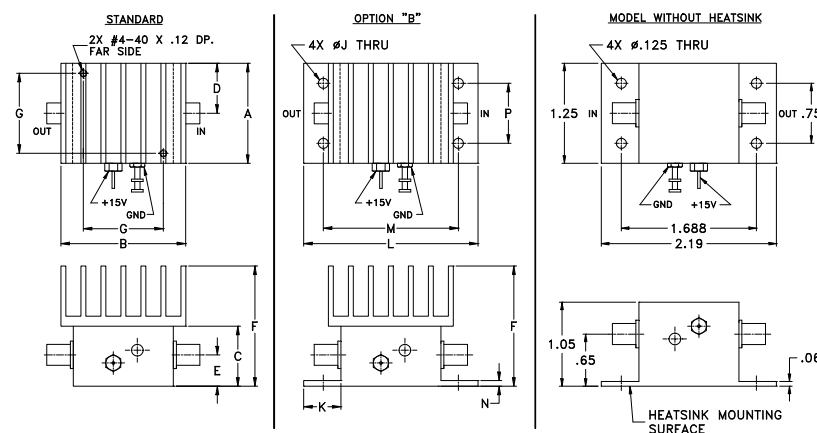

Outline Dimensions (inch/mm)

A	B	C	D	E	F	G	H	J	K	L	M	N	P	wt*
1.25	1.56	.75	.63	.39	1.50	1.000	--	.125	.46	2.19	1.688	.06	.750	grams
31.75	39.62	19.05	16.00	9.91	38.10	25.40	--	3.18	11.68	55.63	42.88	1.52	19.05	85.0
														*70 grams without heat sink

Notes

- Performance and quality attributes and conditions not expressly stated in this specification document are intended to be excluded and do not form a part of this specification document.
- Electrical specifications and performance data contained in this specification document are based on Mini-Circuit's applicable established test performance criteria and measurement instructions.
- The parts covered by this specification document are subject to Mini-Circuits standard limited warranty and terms and conditions (collectively, "Standard Terms"); Purchasers of this part are entitled to the rights and benefits contained therein. For a full statement of the Standard Terms and the exclusive rights and remedies thereunder, please visit Mini-Circuits' website at www.minicircuits.com/WCLStore/terms.jsp

REV. F
ECO-010199
ZFL-2000+
211019



FREQUENCY (MHz)	GAIN (dB)			DIRECTIVITY (dB)			VSWR (:1)		NOISE FIGURE (dB)	POUT at 1 dB COMPR. (dBm)
	12V	15V	16V	12V	15V	16V	IN	OUT		
10.00	20.67	21.23	21.35	17.50	16.70	16.80	1.65	1.78	5.52	15.80
19.10	20.87	21.42	21.53	16.80	16.40	16.60	1.62	1.44	5.24	16.11
50.50	20.82	21.38	21.49	17.10	16.80	16.60	1.62	1.30	4.28	15.83
133.40	20.79	21.34	21.45	17.00	16.50	16.20	1.60	1.30	3.96	15.95
352.30	20.77	21.30	21.41	16.10	15.80	15.80	1.56	1.33	4.14	16.30
724.40	21.03	21.53	21.64	14.50	13.90	13.90	1.43	1.35	4.23	16.76
877.40	21.07	21.56	21.65	13.80	13.30	13.00	1.37	1.27	4.28	16.72
1030.50	20.97	21.46	21.55	13.00	12.60	12.60	1.31	1.19	4.39	16.69
1132.60	20.85	21.37	21.47	12.90	12.30	12.30	1.29	1.16	4.44	16.60
1234.60	20.76	21.27	21.37	12.50	12.40	12.40	1.30	1.21	4.49	16.73
1387.70	20.56	21.06	21.14	12.20	11.90	12.10	1.43	1.36	4.59	16.74
1540.80	20.50	20.96	21.02	11.60	11.60	11.50	1.63	1.54	4.78	16.74
1693.80	20.68	21.11	21.17	10.20	10.50	10.50	1.79	1.61	4.90	16.99
1846.90	20.87	21.32	21.40	8.60	9.10	9.10	1.77	1.43	4.99	16.99
2000.00	20.86	21.38	21.47	7.50	7.80	8.10	1.47	1.07	5.30	16.80

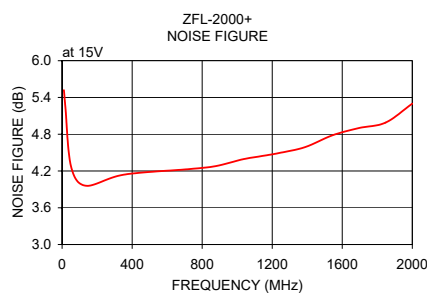
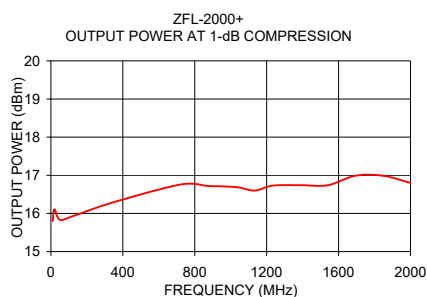
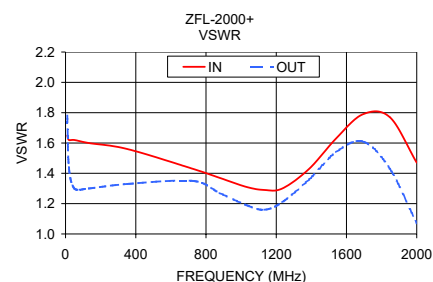
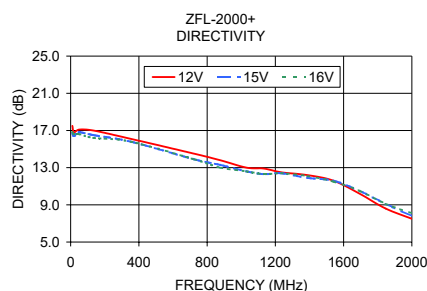
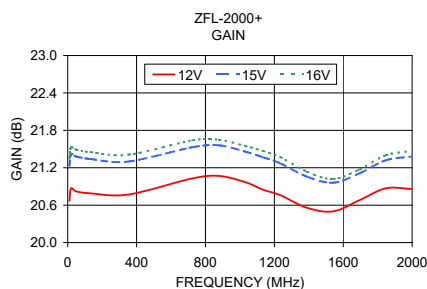

Notes

- A. Performance and quality attributes and conditions not expressly stated in this specification document are intended to be excluded and do not form a part of this specification document.
- B. Electrical specifications and performance data contained in this specification document are based on Mini-Circuit's applicable established test performance criteria and measurement instructions.
- C. The parts covered by this specification document are subject to Mini-Circuits standard limited warranty and terms and conditions (collectively, "Standard Terms"); Purchasers of this part are entitled to the rights and benefits contained therein. For a full statement of the Standard Terms and the exclusive rights and remedies thereunder, please visit Mini-Circuits' website at www.minicircuits.com/MCLStore/terms.jsp



Amplifier

ZFL-2000+

Typical Performance Data

FREQUENCY (MHz)	GAIN (dB)			DIRECTIVITY (dB)			VSWR IN (:1) 15V	VSWR OUT (:1) 15V	NOISE FIGURE (dB) 15V	Pout at 1dB Comp. (dBm) 15V
	12V	15V	16V	12V	15V	16V				
10.0	20.67	21.23	21.35	17.50	16.70	16.80	1.65	1.78	5.52	15.80
19.1	20.87	21.42	21.53	16.80	16.40	16.60	1.62	1.44	5.24	16.11
50.5	20.82	21.38	21.49	17.10	16.80	16.60	1.62	1.30	4.28	15.83
133.4	20.79	21.34	21.45	17.00	16.50	16.20	1.60	1.30	3.96	15.95
352.3	20.77	21.30	21.41	16.10	15.80	15.80	1.56	1.33	4.14	16.30
724.4	21.03	21.53	21.64	14.50	13.90	13.90	1.43	1.35	4.23	16.76
877.4	21.07	21.56	21.65	13.80	13.30	13.00	1.37	1.27	4.28	16.72
1030.5	20.97	21.46	21.55	13.00	12.60	12.60	1.31	1.19	4.39	16.69
1132.6	20.85	21.37	21.47	12.90	12.30	12.30	1.29	1.16	4.44	16.60
1234.6	20.76	21.27	21.37	12.50	12.40	12.40	1.30	1.21	4.49	16.73
1387.7	20.56	21.06	21.14	12.20	11.90	12.10	1.43	1.36	4.59	16.74
1540.8	20.50	20.96	21.02	11.60	11.60	11.50	1.63	1.54	4.78	16.74
1693.8	20.68	21.11	21.17	10.20	10.50	10.50	1.79	1.61	4.90	16.99
1846.9	20.87	21.32	21.40	8.60	9.10	9.10	1.77	1.43	4.99	16.99
2000.0	20.86	21.38	21.47	7.50	7.80	8.10	1.47	1.07	5.30	16.80

REV. X1
ZFL-2000+
060913
Page 1 of 1



IF/RF MICROWAVE COMPONENTS • ISO 9001 ISO 14001 AS 9100 CERTIFIED • RoHS compliant
P.O. Box 350166, Brooklyn, New York 11235-0003 (718) 934-4500 Fax (718) 332-4661



The Design Engineers Search Engine finds the model you need, Instantly • For detailed performance specs & shopping online see



Typical Performance Curves

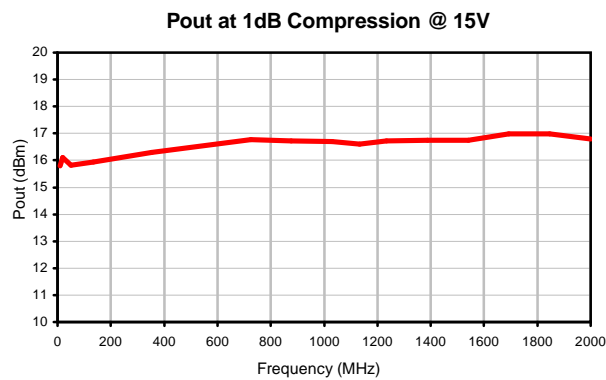
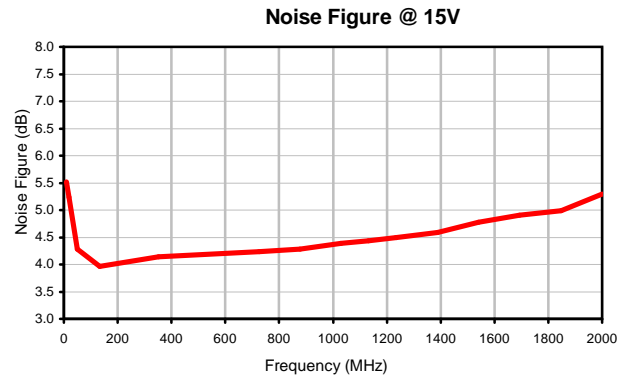
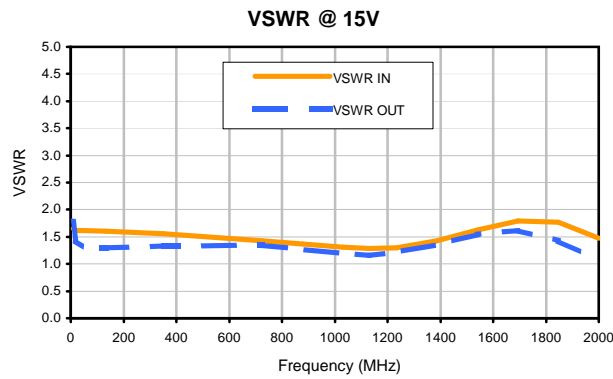
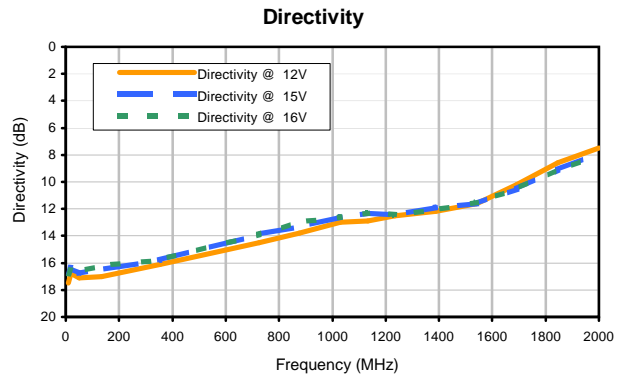
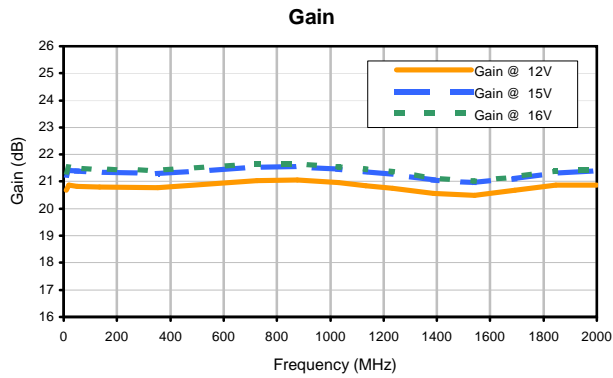

Case Style

SS

SS98

Outline Dimensions

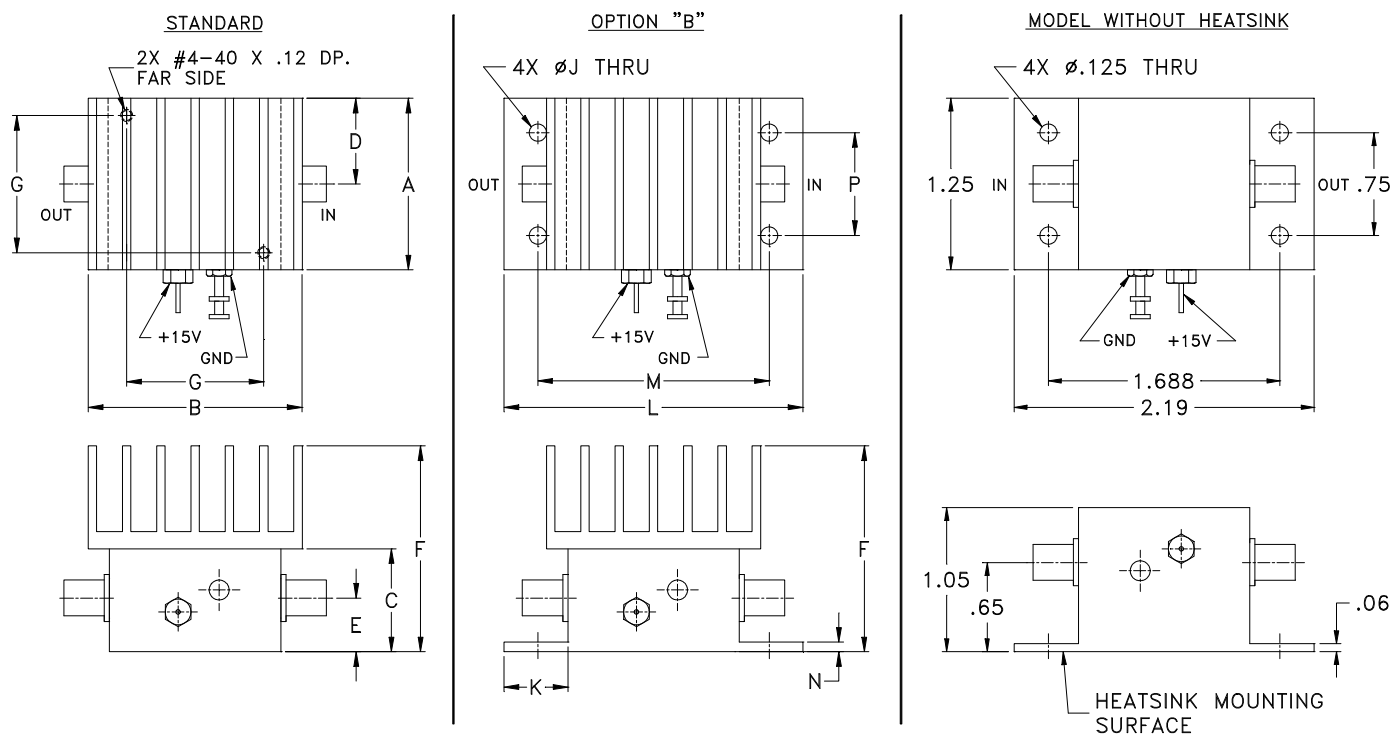

CASE#	A	B	C	D	E	F	G	H	J	K	L	M	N
SS98	1.25 (31.75)	1.56 (39.62)	.75 (19.05)	.63 (16.00)	.39 (9.91)	1.50 (38.10)	1.000 (25.40)	--	.125 (3.18)	.46 (11.68)	2.19 (55.63)	1.688 (42.88)	.06 (1.52)

CASE#	P	WT. GRAMS	WT. WITHOUT HEATSINK GRAMS
SS98	.750 (19.05)	85.0	70.0

Dimensions are in inches (mm). Tolerances: 2 Pl. $\pm .03$; 3 Pl. $\pm .015$

Notes:

- Case material: Aluminum alloy.
- Case finish:
For RoHS Case Styles: Clear chemical conversion coating, non-chrome or trivalent chrome based.
- Heat sink finish: Black anodize.
- Refer to the individual model data sheet for the type of connector available.

Mini-Circuits[®]

INTERNET <http://www.minicircuits.com>

P.O. Box 350166, Brooklyn, New York 11235-0003 (718) 934-4500 Fax (718) 332-4661

Distribution Centers NORTH AMERICA 800-654-7949 • 417-335-5935 • Fax 417-335-5945 • EUROPE 44-1252-832600 • Fax 44-1252-837010

Mini-Circuits ISO 9001 & ISO 14001 Certified



All Mini-Circuits products are manufactured under exacting quality assurance and control standards, and are capable of meeting published specifications after being subjected to any or all of the following physical and environmental test.

Specification	Test/Inspection Condition	Reference/Spec
Operating Temperature	-20° to 71° C Ambient Environment	Individual Model Data Sheet
Storage Temperature	-55° to 100° C Ambient Environment	Individual Model Data Sheet
Stabilization Bake	(non-operating) 125°C, 24 hours	- - -
Burn-in at Elevated Temp.	(DC on) 160 hours at 85° C	MIL-STD-202, Method 108
Thermal Shock	-55° to 100°C, 5 cycles	MIL-STD-202, Method 107, Condition A, except 100°C