

Coaxial Directional Coupler

50Ω

20 to 2000 MHz

ZFDC-6-23-S+



Generic photo used for illustration purposes only

CASE STYLE: K18

Connectors	Model
SMA	ZFDC-6-23-S+
BRACKET (OPTION "B")	

+RoHS Compliant

The +Suffix identifies RoHS Compliance. See our web site for RoHS Compliance methodologies and qualifications

Maximum Ratings

Operating Temperature	-55°C to 100°C
Storage Temperature	-55°C to 100°C

Coaxial Connections

INPUT	3
OUTPUT	1
COUPLED	2

Outline Drawing

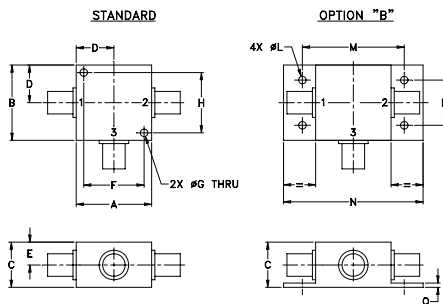

Outline Dimensions (inch/mm)

A	B	C	D	E	F	G	H
1.25	1.25	.75	.63	.38	1.00	.125	1.000
31.75	31.75	19.05	16.00	9.65	25.40	3.18	25.40
J	K	L	M	N	P	Q	wt
--	--	.125	1.688	2.18	.75	.07	grams
--	--	3.18	42.88	55.37	19.05	1.78	70.0

Electrical Schematic

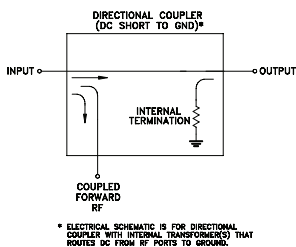

Features

- very wideband, 20 to 2000 MHz
- good directivity, 17 dB typ.
- can be used for unbalance 2 way splitter
- rugged shielded case

Applications

- cellular
- instrumentation
- communication receivers & transmitters
- GPS

Electrical Specifications at 25°C

Parameter	Condition (MHz)	Min.	Typ.	Max.	Unit
Frequency Range		20		2000	MHz
Mainline Loss¹	20-1300	—	2.0	2.8	dB
	1300-2000	—	2.7	3.5	
Nominal Coupling	20-2000	—	6.4±0.5	—	dB
Coupling Flatness(±)	20-2000	—	0.3	0.7	dB
Directivity	20-2000	11	18	—	dB
Return Loss (Input)	20-700	11	16	—	dB
	700-1600	15	22	—	
	1600-2000	12	18	—	
Return Loss (Output)	20-700	14	22	—	dB
	700-1600	17	24	—	
	1600-2000	14	22	—	
Return Loss (Coupling)	20-700	11	16	—	dB
	700-1600	10	15	—	
	1600-2000	10	14	V	
Input Power	20-2000			0.5	W

1. Include coupling loss.

Typical Performance Data

Frequency (MHz)	Mainline Loss (dB) In-Out	Coupling (dB) In-Cpl	Directivity (dB)	Return Loss (dB)		
				In	Out	Cpl
20	2.13	6.64	15.21	13.94	17.62	13.81
50	1.94	6.58	15.87	15.69	22.88	15.49
200	1.86	6.59	16.01	17.46	26.12	16.89
400	1.89	6.58	15.95	18.53	26.28	17.24
700	1.94	6.50	15.95	20.19	25.13	17.28
1000	2.04	6.39	16.12	22.58	23.61	16.88
1300	2.22	6.28	16.52	25.66	22.97	15.80
1600	2.48	6.18	16.54	25.36	21.71	14.31
1800	2.72	6.14	15.80	22.29	20.07	13.41
2000	3.02	6.12	14.54	18.96	17.99	12.50

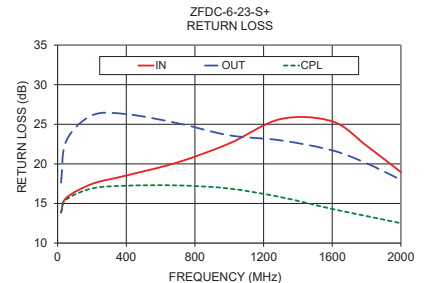
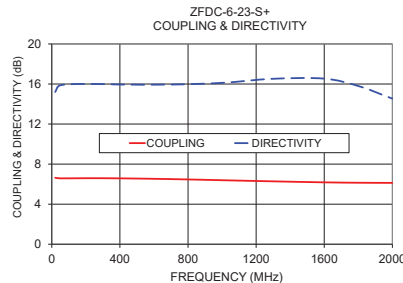
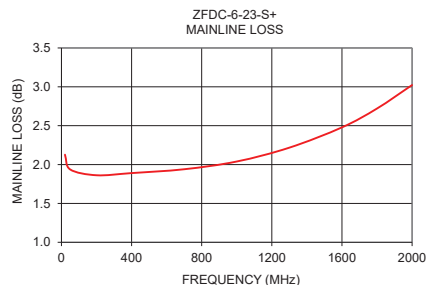

Notes

- Performance and quality attributes and conditions not expressly stated in this specification document are intended to be excluded and do not form a part of this specification document.
- Electrical specifications and performance data contained in this specification document are based on Mini-Circuit's applicable established test performance criteria and measurement instructions.
- The parts covered by this specification document are subject to Mini-Circuit's standard limited warranty and terms and conditions (collectively, "Standard Terms"); Purchasers of this part are entitled to the rights and benefits contained therein. For a full statement of the Standard Terms and the exclusive rights and remedies thereunder, please visit Mini-Circuit's website at www.minicircuits.com/WCLStore/terms.jsp

Mini-Circuits®

www.minicircuits.com P.O. Box 350166, Brooklyn, NY 11235-0003 (718) 934-4500 sales@minicircuits.com

REV. OR
ECO-001941
ZFDC-6-23-S+
ED-19081401
YL/CP/AM
200226

Typical Performance Data

FREQUENCY (MHz)	INSERTION LOSS (dB)	COUPLING (dB)	DIRECTIVITY (dB)	RETURN LOSS (dB)		
				IN	OUT	CPL
9	2.46	6.75	13.96	11.45	12.32	11.38
15	2.22	6.67	14.82	13.19	15.71	13.07
20	2.13	6.64	15.21	13.94	17.62	13.81
25	2.07	6.62	15.45	14.42	19.05	14.30
30	2.03	6.60	15.59	14.80	20.15	14.65
50	1.94	6.58	15.87	15.69	22.88	15.49
100	1.87	6.57	16.08	16.76	25.28	16.37
150	1.86	6.58	15.97	17.41	25.98	16.79
200	1.86	6.59	16.01	17.46	26.12	16.89
250	1.87	6.59	16.05	17.60	26.66	16.93
300	1.87	6.59	16.07	17.79	26.78	16.98
350	1.88	6.59	16.00	18.05	26.39	17.12
400	1.89	6.58	15.95	18.53	26.28	17.24
450	1.90	6.57	15.94	18.65	25.90	17.24
500	1.90	6.56	16.00	18.83	26.28	17.15
600	1.92	6.53	16.01	19.12	25.68	17.21
700	1.94	6.50	15.95	20.19	25.13	17.28
800	1.97	6.46	16.02	20.72	25.21	17.09
900	2.00	6.43	16.13	21.38	24.64	17.02
1000	2.04	6.39	16.12	22.58	23.61	16.88
1050	2.06	6.37	16.20	23.07	23.99	16.65
1100	2.09	6.35	16.34	23.30	23.67	16.46
1150	2.12	6.34	16.38	23.57	23.60	16.36
1200	2.15	6.32	16.41	24.55	23.67	16.23
1250	2.18	6.30	16.46	25.19	22.84	16.05
1300	2.22	6.28	16.52	25.66	22.97	15.80
1350	2.25	6.26	16.63	26.24	22.98	15.49
1400	2.30	6.24	16.70	25.97	22.63	15.25
1450	2.34	6.23	16.71	26.10	22.70	15.08
1500	2.38	6.21	16.65	26.59	22.42	14.88
1550	2.43	6.20	16.58	25.87	21.64	14.61
1600	2.48	6.18	16.54	25.36	21.71	14.31
1650	2.54	6.17	16.46	24.71	21.34	14.01
1700	2.60	6.16	16.32	23.67	20.68	13.79
1750	2.66	6.15	16.05	23.03	20.93	13.62
1800	2.72	6.14	15.80	22.29	20.07	13.41
1850	2.79	6.13	15.52	21.30	19.49	13.12
1900	2.86	6.12	15.23	20.49	19.23	12.86
1950	2.94	6.12	14.95	19.94	18.57	12.66
2000	3.02	6.12	14.54	18.96	17.99	12.50
2100	3.18	6.13	13.74	17.82	17.17	12.21
2200	3.36	6.13	12.98	16.56	16.24	11.84
2300	3.56	6.16	12.16	15.47	15.34	11.66
2400	3.77	6.20	11.34	14.47	14.33	11.52

Directional Coupler

Typical Performance Curves

ZFDC-6-23-S+

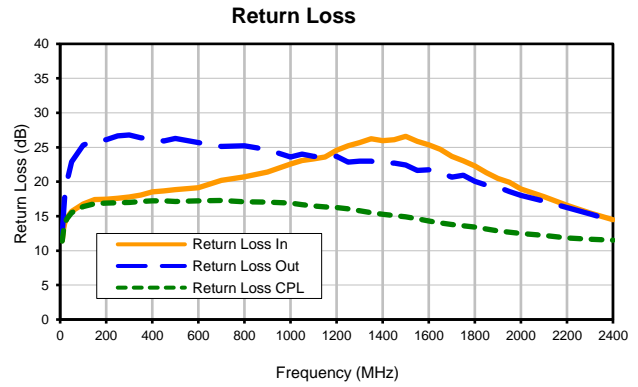
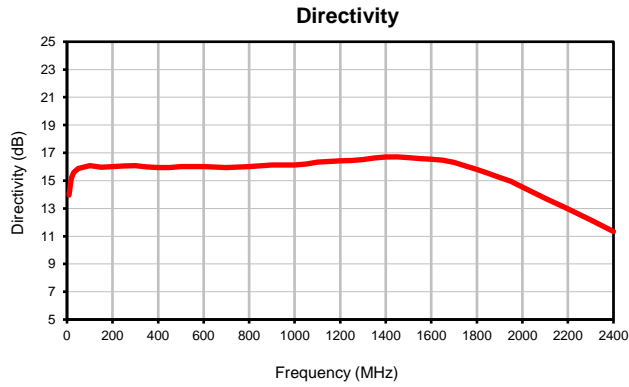
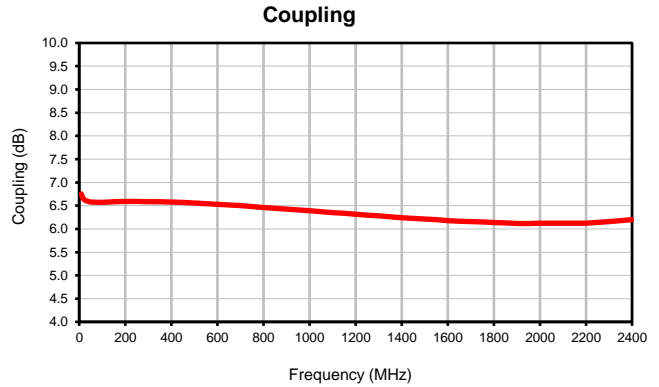
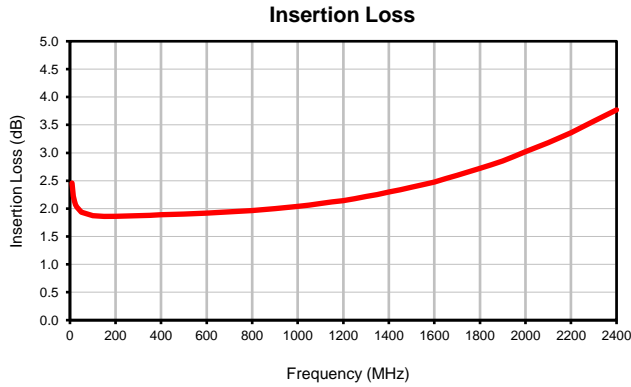

P.O. Box 350166, Brooklyn, New York 11235-0003 (718) 934-4500 • Fax (718) 332-4661 For detailed performance specs & shopping online see Mini-Circuits web site
 The Design Engineers Search Engine Provides ACTUAL Data Instantly From MINI-CIRCUITS At: www.minicircuits.com



IF/RF MICROWAVE COMPONENTS

REV. OR
 ZFDC-6-23-S+
 7/28/2020
 Page 1 of 1

Outline Dimensions



CASE#	A	B	C	D	E	F	G	H	J	K	L	M	N
K18	1.25 (31.75)	1.25 (31.75)	.75 (19.05)	.63 (16.00)	.38 (9.65)	1.000 (25.40)	.125 (3.18)	1.000 (25.40)	--	--	.125 (3.18)	1.688 (42.88)	2.18 (55.37)

CASE#	P	Q	WT. GRAMS
K18	.75 (19.05)	.07 (1.78)	70.0

Dimensions are in inches (mm). Tolerances: 2 Pl. $\pm .03$; 3 Pl. $\pm .015$

Notes:

- Case material: Aluminum alloy.
- Case finish:
For RoHS Case Styles: Clear chemical conversion coating, non-chrome or trivalent chrome based.
- Mounting bracket available on request. Add suffix B to part number.
- For port marking 1, 2, and 3 see specifications data sheet.
- For bracket version, option B, dimension "C" changes from .75 to .94 inches when connectors are type N.
- Refer to the individual model data sheet for the type of connectors available.

Mini-Circuits®

INTERNET <http://www.minicircuits.com>

P.O. Box 350166, Brooklyn, New York 11235-0003 (718) 934-4500 Fax (718) 332-4661

Distribution Centers NORTH AMERICA 800-654-7949 • 417-335-5935 • Fax 417-335-5945 • EUROPE 44-1252-832600 • Fax 44-1252-837010

Mini-Circuits ISO 9001 & ISO 14001 Certified



All Mini-Circuits products are manufactured under exacting quality assurance and control standards, and are capable of meeting published specifications after being subjected to any or all of the following physical and environmental test.

Specification	Test/Inspection Condition	Reference/Spec
Operating Temperature	-55° to 100°C Ambient Environment	Individual Model Data Sheet
Storage Temperature	-55° to 100° C Ambient Environment	Individual Model Data Sheet
Barometric Pressure	100,000 Feet	MIL-STD-202, Method 105, Condition D
Humidity	90% RH, 65°C Units may require bake-out after humidity to restore full performance.	MIL-STD-202, Method 103
Thermal Shock	-65° to 125°C, 5 cycles	MIL-STD-202, Method 107, Condition B
Vibration (High Frequency)	20g peak, 10-2000 Hz, 12 times in each of three perpendicular directions (total 36)	MIL-STD-202, Method 204, Condition D
Mechanical Shock	100g, 6ms sawtooth, 3 shocks each direction 3 axes (total 18)	MIL-STD-202, Method 213, Condition I