

# Coaxial Directional Coupler

50Ω

20 to 3000 MHz

ZFDC-20-33+



Generic photo used for illustration purposes only  
CASE STYLE: K18

Connectors	Model
SMA	ZFDC-20-33-S+
N-TYPE	ZFDC-20-33-N+
BRACKET (OPTION "B")	

**+RoHS Compliant**

The +Suffix identifies RoHS Compliance. See our web site for RoHS Compliance methodologies and qualifications

## Maximum Ratings

Operating Temperature	-40°C to 85°C
Storage Temperature	-55°C to 100°C

## Coaxial Connections

INPUT	3
OUTPUT	1
COUPLED	2

## Outline Drawing

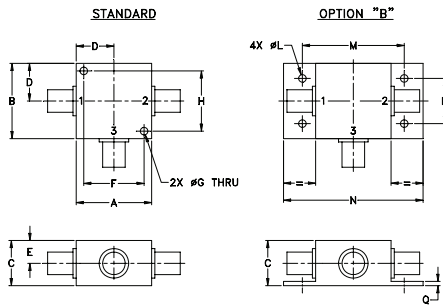

## Outline Dimensions (inch/mm)

A	B	C	D	E	F	G	H	
1.25	1.25	.75	.63	.38	1.00	.125	1.000	
31.75	31.75	19.05	16.00	9.65	25.40	3.18	25.40	
J	K	L	M	N	P	Q	wt	
--	--	.125	1.688	2.18	.75	.07	grams	
--	--	3.18	42.88	55.37	19.05	1.78	70.0	

## Electrical Schematic

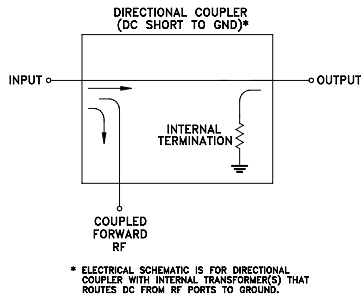

## Features

- very wideband, 20 to 3000 MHz
- excellent directivity, 20 dB typ.
- excellent mainline loss, 1.0 dB typ.
- rugged shielded case

## Applications

- cellular
- GPS
- instrumentation
- communication receivers & transmitters

## Electrical Specifications at 25°C

Parameter	Condition (MHz)	Min.	Typ.	Max.	Unit
<b>Frequency Range</b>		20	—	3000	MHz
<b>Mainline Loss</b> (above theoretical 0.05 dB)	20	—	0.4	0.65	dB
	200	—	0.4	0.65	
	1500	—	0.9	1.20	
	2500	—	1.3	1.6	
	3000	—	1.4	1.8	
<b>Coupling</b>	20	19.9	20.5	21.1	dB
	200	20.3	20.9	21.5	
	1500	19.8	21.3	22.8	
	2500	19.0	20.7	22.4	
	3000	19.0	20.9	22.7	
<b>Coupling Flatness</b> (±)	20 - 1500	—	0.5	1.0	dB
	1500 - 2500	—	0.4	0.8	
	2500 - 3000	—	0.1	0.6	
<b>Directivity</b>	20	19	25	—	dB
	200	19	25	—	
	1500	12	15	—	
	2500	11	14	—	
	3000	10	14	—	
<b>Return Loss (Input)</b>	20 - 1500	18	24	—	dB
	1500 - 3000	12	18	—	
<b>Return Loss (Output)</b>	20 - 1500	18	24	—	dB
	1500 - 3000	12	18	—	
<b>Return Loss (Coupling)</b>	20 - 1500	12	19	—	dB
	1500 - 3000	10	14	—	
<b>Input Power</b>	20 - 1500	—	—	0.5	W
	1500 - 3000	—	—	1.0	

## Typical Performance Data

Frequency (MHz)	Mainline Loss (dB) In-Out	Coupling (dB) In-Cpl	Directivity (dB)	Return Loss (dB)		
				In	Out	Cpl
20.00	0.42	20.57	27.05	24.72	25.23	23.24
50.00	0.40	20.68	31.57	28.55	29.48	27.78
100.00	0.40	20.77	32.98	31.12	32.70	31.38
150.00	0.41	20.85	33.46	33.09	34.41	33.95
200.00	0.43	20.94	32.14	32.67	34.65	36.39
1000.00	0.65	21.59	18.10	38.49	28.67	22.93
1600.00	0.81	21.19	14.40	45.73	24.89	18.57
2000.00	0.92	20.82	13.77	36.01	23.12	18.07
2600.00	1.13	20.45	14.94	23.69	20.58	19.26
3000.00	1.31	20.43	17.39	18.12	17.93	16.15

ZFDC-20-33-S+ MAINLINE LOSS

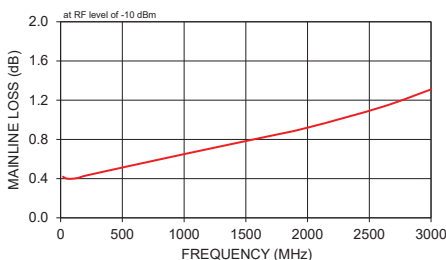

ZFDC-20-33-S+ COUPLING & DIRECTIVITY

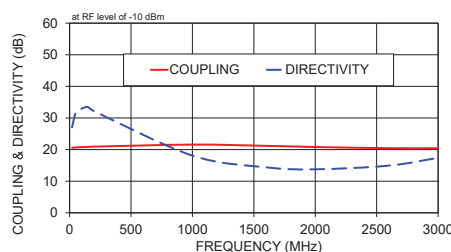

ZFDC-20-33-S+ RETURN LOSS

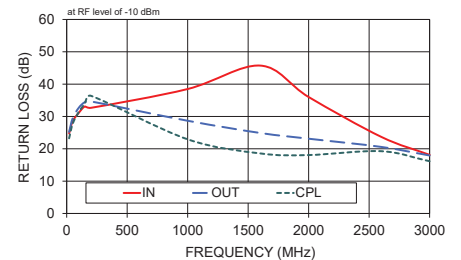

### Notes

- Performance and quality attributes and conditions not expressly stated in this specification document are intended to be excluded and do not form a part of this specification document.
- Electrical specifications and performance data contained in this specification document are based on Mini-Circuit's applicable established test performance criteria and measurement instructions.
- The parts covered by this specification document are subject to Mini-Circuit's standard limited warranty and terms and conditions (collectively, "Standard Terms"); Purchasers of this part are entitled to the rights and benefits contained therein. For a full statement of the Standard Terms and the exclusive rights and remedies thereunder, please visit Mini-Circuit's website at [www.minicircuits.com/WCLStore/terms.jsp](http://www.minicircuits.com/WCLStore/terms.jsp)



# Directional Coupler

# ZFDC-20-33+

## Typical Performance Data

FREQUENCY (MHz)	INSERTION LOSS (dB)	COUPLING (dB)	DIRECTIVITY (dB)	RETURN LOSS (dB)		
				IN	OUT	CPL
3	0.49	20.06	11.71	12.21	12.11	9.84
7	0.40	20.45	19.26	19.43	19.49	16.98
9	0.43	20.49	21.41	21.02	21.20	18.72
10	0.43	20.50	22.18	21.62	21.84	19.37
20	0.42	20.57	27.05	24.72	25.23	23.24
30	0.41	20.62	29.46	26.49	27.16	25.36
40	0.40	20.65	30.81	27.67	28.51	26.73
50	0.40	20.68	31.57	28.55	29.48	27.78
100	0.40	20.77	32.98	31.12	32.70	31.38
150	0.41	20.85	33.46	33.09	34.41	33.95
200	0.43	20.94	32.14	32.67	34.65	36.39
400	0.48	21.26	28.51	33.43	35.03	38.02
600	0.54	21.50	24.56	34.04	34.69	30.24
800	0.60	21.60	20.95	35.53	31.59	25.84
1000	0.65	21.59	18.10	38.49	28.67	22.93
1200	0.71	21.52	16.23	44.18	26.88	20.89
1400	0.76	21.38	15.07	53.52	25.73	19.47
1600	0.81	21.19	14.40	45.73	24.89	18.57
1800	0.86	21.00	13.99	40.38	23.99	18.11
2000	0.92	20.82	13.77	36.01	23.12	18.07
2200	0.99	20.66	13.81	31.60	22.32	18.44
2400	1.05	20.53	14.16	27.31	21.52	19.02
2600	1.13	20.45	14.94	23.69	20.58	19.26
2800	1.21	20.42	16.06	20.67	19.39	18.31
2900	1.26	20.42	16.69	19.34	18.72	17.32
2950	1.29	20.42	17.06	18.67	18.33	16.75
3000	1.31	20.43	17.39	18.12	17.93	16.15
3050	1.34	20.45	17.79	17.51	17.55	15.52
3100	1.36	20.46	18.15	16.94	17.14	14.89
3200	1.42	20.52	18.97	15.94	16.33	13.62
3300	1.48	20.58	19.92	14.96	15.53	12.42
3400	1.55	20.67	20.91	14.13	14.78	11.30
3500	1.62	20.77	21.82	13.36	14.09	10.27
3600	1.69	20.89	22.37	12.63	13.45	9.34
3700	1.76	21.03	21.96	11.98	12.86	8.50
3800	1.84	21.18	20.63	11.37	12.36	7.75
3900	1.92	21.35	18.81	10.82	11.90	7.08
4000	2.00	21.52	16.83	10.31	11.50	6.48



# Directional Coupler

# ZFDC-20-33+

## Typical Performance Curves

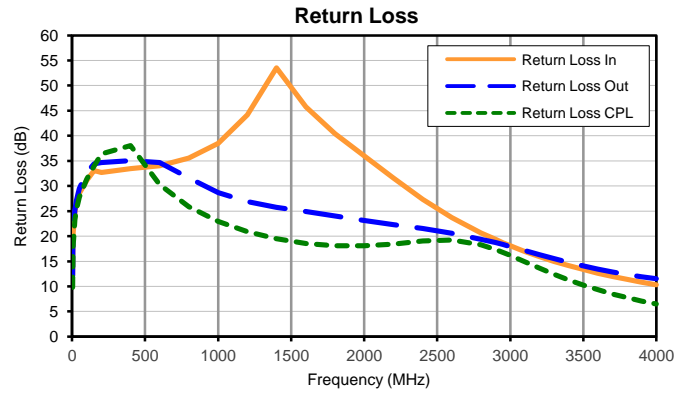
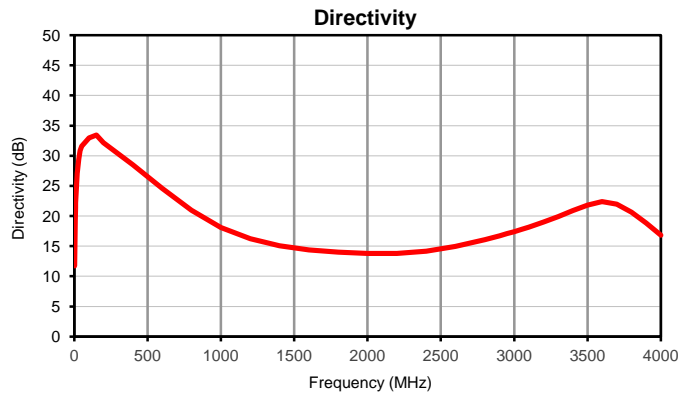
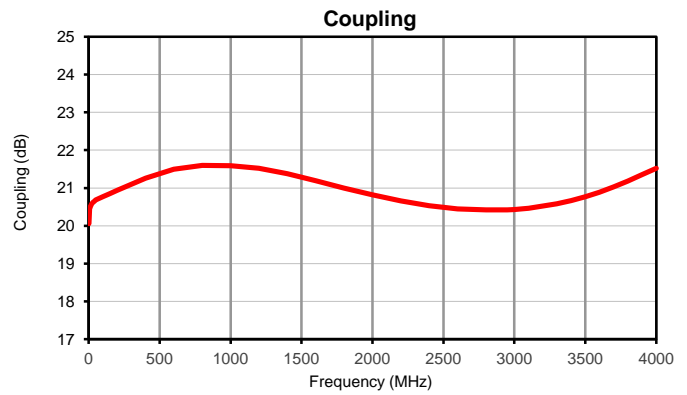
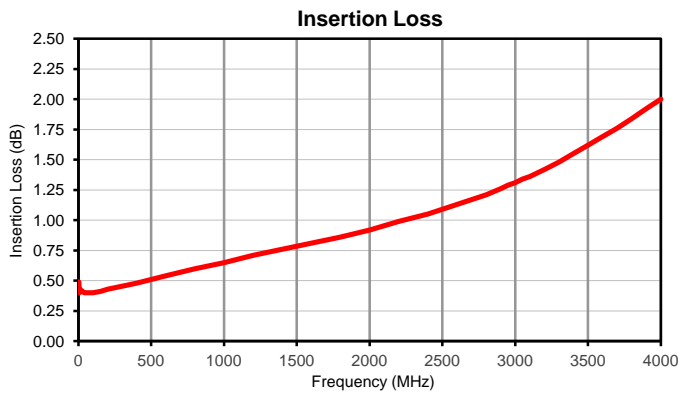

# Case Style

# K

## K18

### Outline Dimensions

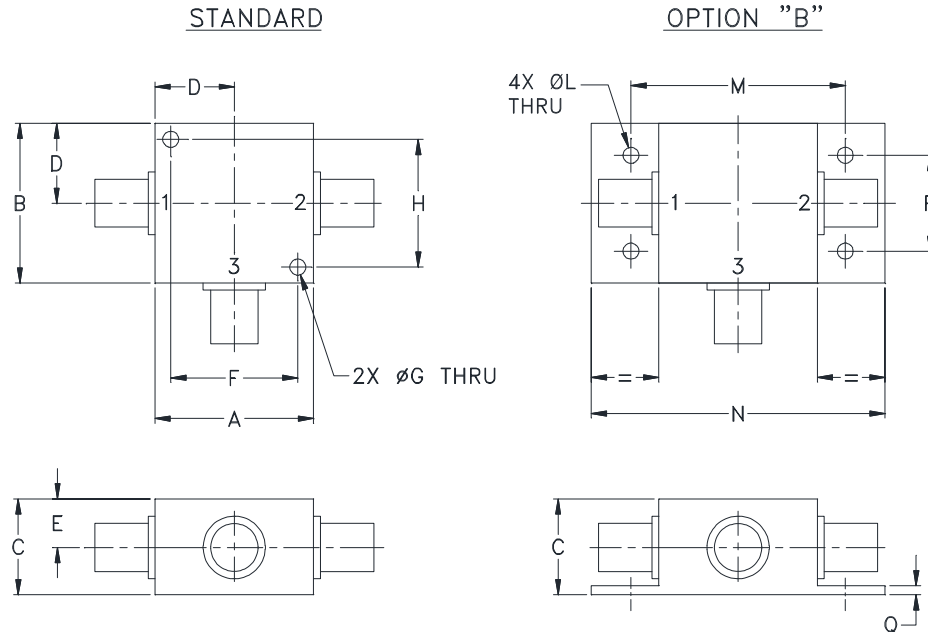

CASE#	A	B	C	D	E	F	G	H	J	K	L	M	N
K18	1.25 (31.75)	1.25 (31.75)	.75 (19.05)	.63 (16.00)	.38 (9.65)	1.000 (25.40)	.125 (3.18)	1.000 (25.40)	--	--	.125 (3.18)	1.688 (42.88)	2.18 (55.37)

CASE#	P	Q	WT. GRAMS
K18	.75 (19.05)	.07 (1.78)	70.0

Dimensions are in inches (mm). Tolerances: 2 Pl.  $\pm .03$ ; 3 Pl.  $\pm .015$

#### Notes:

- Case material: Aluminum alloy.
- Case finish:  
For RoHS Case Styles: Clear chemical conversion coating, non-chrome or trivalent chrome based.
- Mounting bracket available on request. Add suffix B to part number.
- For port marking 1, 2, and 3 see specifications data sheet.
- For bracket version, option B, dimension "C" changes from .75 to .94 inches when connectors are type N.
- Refer to the individual model data sheet for the type of connectors available.

**Mini-Circuits®**

INTERNET <http://www.minicircuits.com>

P.O. Box 350166, Brooklyn, New York 11235-0003 (718) 934-4500 Fax (718) 332-4661

Distribution Centers NORTH AMERICA 800-654-7949 • 417-335-5935 • Fax 417-335-5945 • EUROPE 44-1252-832600 • Fax 44-1252-837010

Mini-Circuits ISO 9001 & ISO 14001 Certified



All Mini-Circuits products are manufactured under exacting quality assurance and control standards, and are capable of meeting published specifications after being subjected to any or all of the following physical and environmental test.

Specification	Test/Inspection Condition	Reference/Spec
Operating Temperature	-40° to 85°C	Individual Model Data Sheet
Storage Temperature	-55° to 100° C Ambient Environment	Individual Model Data Sheet
Barometric Pressure	100,000 Feet	MIL-STD-202, Method 105, Condition D
Humidity	90% RH, 65°C Units may require bake-out after humidity to restore full performance.	MIL-STD-202, Method 103
Thermal Shock	-65° to 125°C, 5 cycles	MIL-STD-202, Method 107, Condition B
Vibration (High Frequency)	20g peak, 10-2000 Hz, 12 times in each of three perpendicular directions (total 36)	MIL-STD-202, Method 204, Condition D
Mechanical Shock	100g, 6ms sawtooth, 3 shocks each direction 3 axes (total 18)	MIL-STD-202, Method 213, Condition I